

- 1.0 GENERAL NOTES
 1.1 ALL METRIC DIMENSIONS ARE IN BRACKETS [X.X]
 1.2 FOR PATENT INFO: <https://www.cs-pat.com>
 2.0 DESIGN NOTES
 2.1 ANY HAZARDS OR OBSTRUCTIONS TO THE CLIMBING FACILITY AND SAFETY CLIMB MUST BE IDENTIFIED PRIOR TO INSTALLING THE APPURTENANCE. ADDITIONAL PRODUCTS MAY BE REQUIRED TO MAINTAIN THE INTEGRITY OF THE SAFETY CLIMB. DURING INSTALLATION, TEMPORARY AND/OR PERMANENT PRECAUTIONARY MEASURES SHOULD BE TAKEN TO PRESERVE THE CLIMBING FACILITY AND/OR SAFETY CLIMB.
 3.0 MANUFACTURING/SPECIAL REQUIREMENTS
 3.1 TIGHTEN ALL BOLTS SECURING FLAT PLATES BY THE TURN-OF-NUT METHOD. TIGHTEN ALL U-BOLTS USING TURN-OF-NUT METHOD WITH ATTENTION TO LEAVE EQUAL DISTANCE AND EQUAL FORCE ON EACH LEG OF THE U-BOLT.
 4.0 TEST
 5.0 PACKAGING
 5.1 PACKAGING SHALL MEET COMMSCOPE REQUIREMENTS PER DOCUMENT IS-PL-3005
 5.2 PRINTED DOCUMENT TO BE PLACED INSIDE POLYBAG AND THEN IN SHIPPING CONTAINER
 5.3 EXTRA HARDWARE MAY BE SUPPLIED, BAGGED AND SHIPPED

REVISIONS			
REV.	DESCRIPTION	DATE	APPROVED
A	INITIAL RELEASE	LS1146 30MAY24	XK1001 40196865CMO

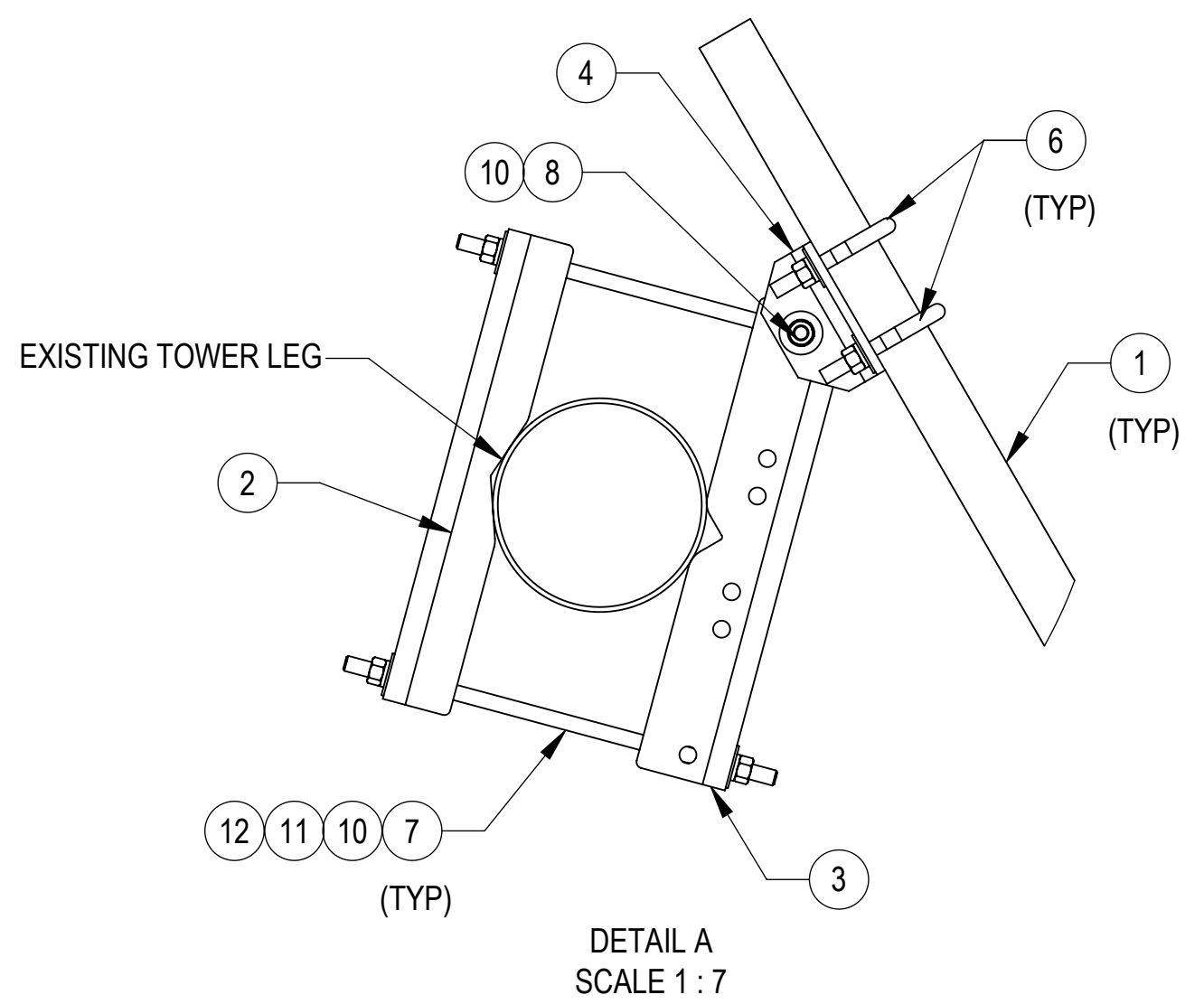
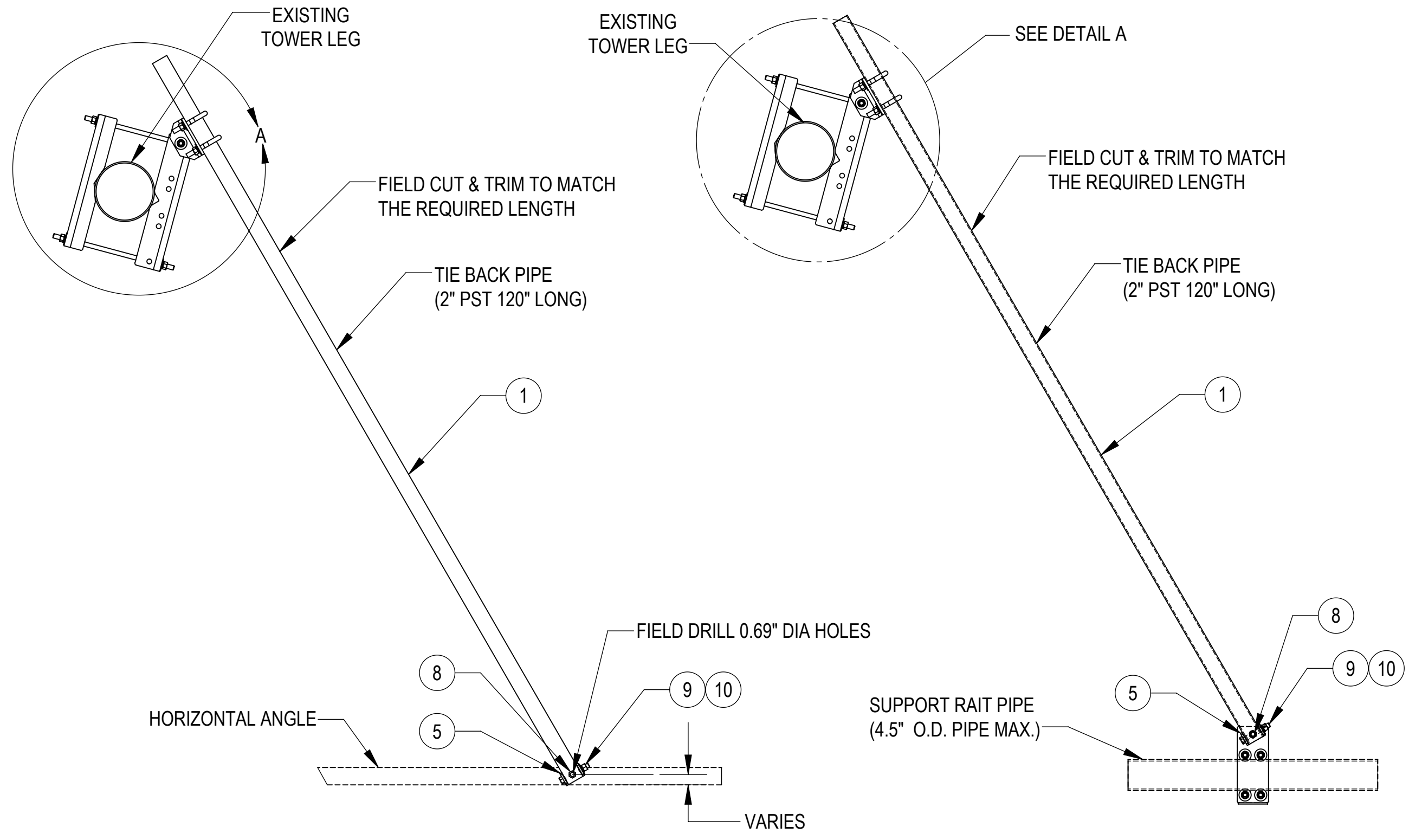

PLAN VIEW
 TIE BACK ASSEMBLY ADAPTER FOR ANGLE

PLAN VIEW
 TIE BACK ASSEMBLY WITH ADAPTER FOR PIPE

DENSITY		lbs/in ³
MASS	102.96	lbs
VOLUME	366.44	in ³
SURFACE AREA	3213.33	in ²
HEIGHT	(20.0")	
LENGTH	(120.0")	
WIDTH	(12.0")	

COMMSCOPE, INC. OF NORTH CAROLINA

TOLERANCES
 1 PLACE .X[X] ± 0.2[6.3] 3 PLACE .XXX[X] ± 0.060[1.5]
 2 PLACE .XX[X] ± 0.12[3.0] ANGLES ± 2°

SAP MATERIAL MASTER
VZWSMART-SFK1L

FINISH: _____ MATERIAL: _____

UNLESS OTHERWISE SPECIFIED DIMENSIONS ARE IN INCHES INTERPRET PER ANSI Y 14.5M-1994	NAME	DATE	TITLE
CE	LS1146	30MAY24	TIE BACK ASSEMBLY FOR LARGER LEG
RW	LS1146	05/30/2024	
AD	YMENG	05/30/2024	
RE	YMENG	05/30/2024	
ECN	40196865CMO		

SCALE: **1:15** DOCUMENT NO.: **VZWSMART-SFK1L**

SIZE	Auth Group	INSL	MODEL	DRAWING					SHEET
C			VERSION	STATUS	REVISION	VERSION	STATUS	REVISION	
			00	RE	A	00	RE	A	1 OF 2

4

3

2

1

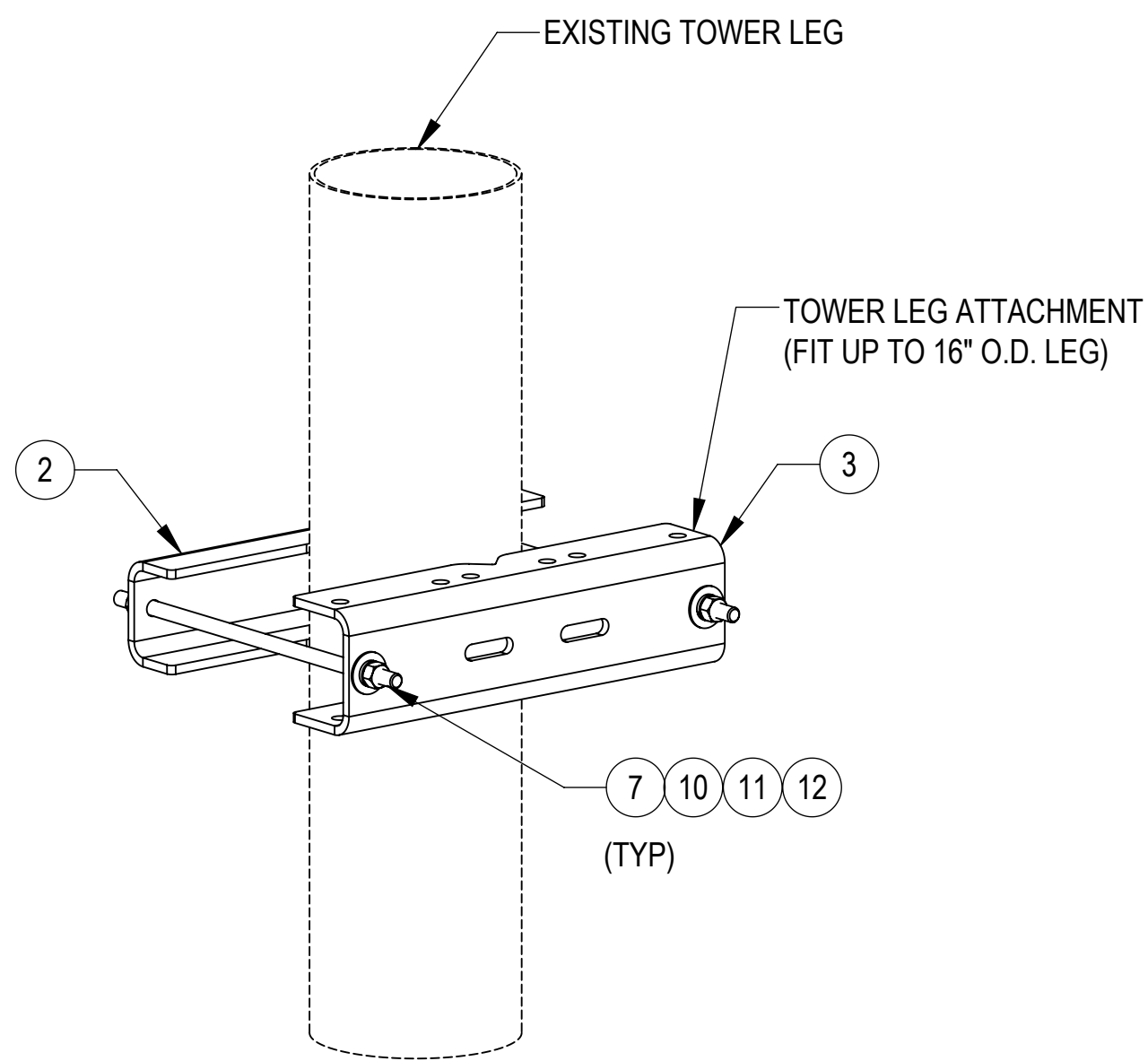

ROUND TOWER LEG ATTACHMENT DETAIL

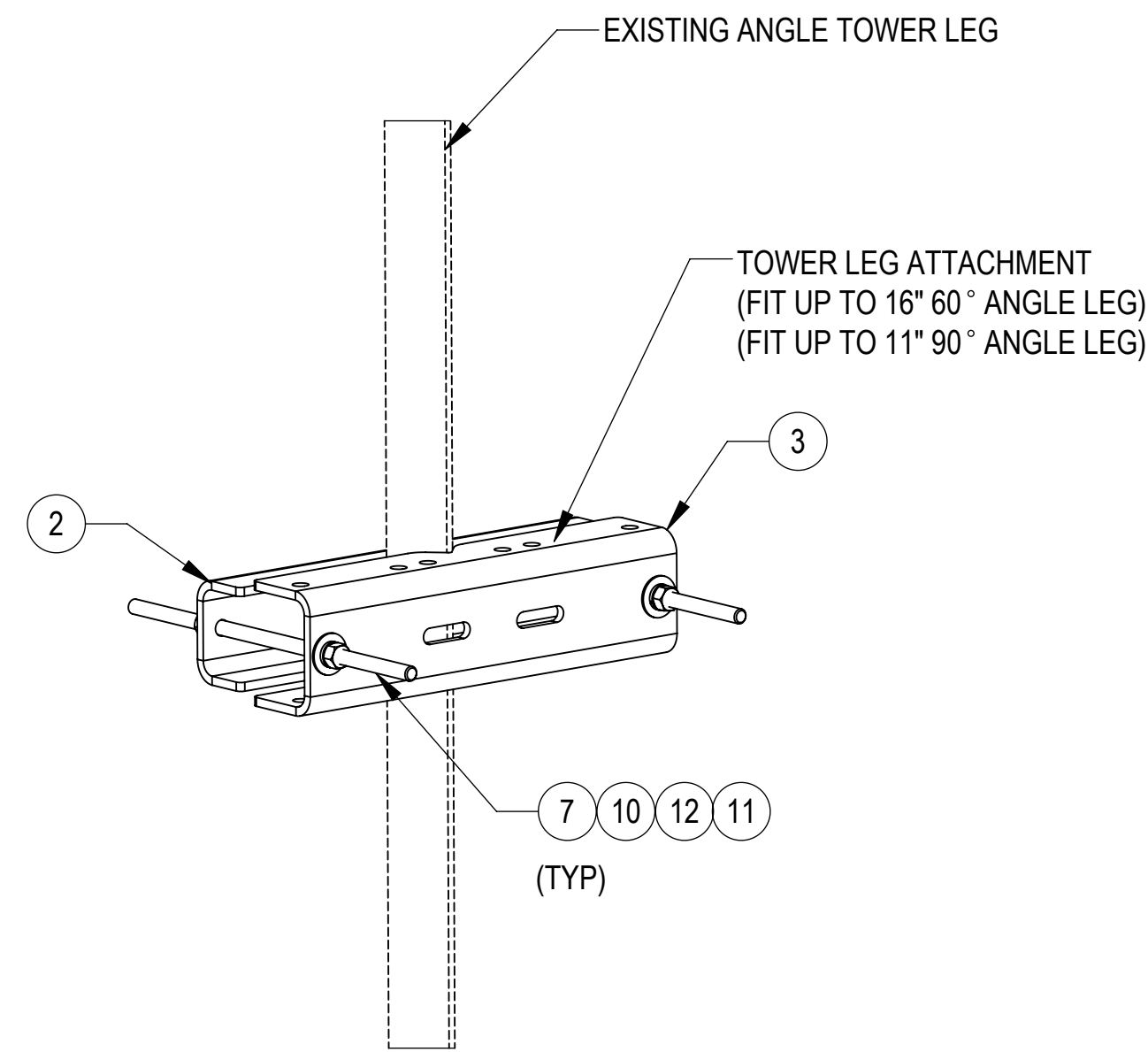

ANGLE TOWER LEG ATTACHMENT DETAIL

COMPONENT PART NUMBERS PROVIDED FOR ASSEMBLY PURPOSES;
INDIVIDUAL COMPONENTS MAY BE SHIPPED AS PARTS WITHIN AN INCLUDED KIT.

THE BOM OF TIE BACK ASSEMBLY ADAPTER FOR ANGLE

ITEM NO.	PART NUMBER	DESCRIPTION	QTY.	WEIGHT	NOTE NO.
1	PST2375-10	PIPE, TIE BACK	1	36.63 LBS	
2	BP8625-19625-00	BENT PLATE, .375 X 4.38 X 19.63	1	17.18 LBS	
3	BP11125-19625-00	BENT PLATE, .375 X 5.25 X 19.63	1	22.61 LBS	
4	MTC4104-0014	BENT PLATE, .375 X 6 X 6.88	1	5.24 LBS	
5	MTC4104-0031	BENT PLATE	1	1.15 LBS	
6	GUB-53050	5/8" X 3" X 5" GALV U-BOLT KIT	2	1.09 LBS	INCLUDES U-BOLT, FLAT WASHERS, LOCK WASHERS AND NUTS
7	MT-382-18	5/8" X 18" GALV THREADED ROD	2	1.55 LBS	
8	GB-0520A	5/8" X 2" GALV BOLT KIT (A325)	2	0.26 LBS	INCLUDES BOLT, LOCK WASHER AND NUT
9	GB-0542A	5/8" X 4-1/4" GALV BOLT KIT	1	0.46 LBS	INCLUDES BOLT, LOCK WASHER AND NUT
10	GWF-05	5/8" GALV FLAT WASHER, 1.7OD	7	0.06 LBS	
11	GWL-05	5/8" GALV LOCK WASHER	4	0.03 LBS	
12	GN-05	5/8" GALV HEX NUT	4	0.08 LBS	

THE BOM OF TIE BACK ASSEMBLY ADAPTER FOR PIPE

ITEM NO.	PART NUMBER	DESCRIPTION	QTY.	WEIGHT	NOTE NO.
1	PST2375-10	PIPE, TIE BACK	1	36.63 LBS	
2	BP8625-19625-00	BENT PLATE, .375 X 4.38 X 19.63	1	17.18 LBS	
3	BP11125-19625-00	BENT PLATE, .375 X 5.25 X 19.63	1	22.61 LBS	
4	MTC4104-0014	BENT PLATE, .375 X 6 X 6.88	1	5.24 LBS	
5	MTC4104-0031	BENT PLATE	1	1.15 LBS	
6	GUB-53050	5/8" X 3" X 5" GALV U-BOLT KIT	2	1.09 LBS	INCLUDES U-BOLT, FLAT WASHERS, LOCK WASHERS AND NUTS
7	MT-382-18	5/8" X 18" GALV THREADED ROD	2	1.55 LBS	
8	GB-0520A	5/8" X 2" GALV BOLT KIT (A325)	2	0.26 LBS	INCLUDES BOLT, LOCK WASHER AND NUT
9	GB-0542A	5/8" X 4-1/4" GALV BOLT KIT	1	0.46 LBS	INCLUDES BOLT, LOCK WASHER AND NUT
10	GWF-05	5/8" GALV FLAT WASHER, 1.7OD	11	0.06 LBS	
11	GWL-05	5/8" GALV LOCK WASHER	4	0.03 LBS	
12	GN-05	5/8" GALV HEX NUT	4	0.08 LBS	
13	PL375-4511	PLATE, TIE BACK MOUNTING	1	5.07 LBS	
14	V-CLAMP	CLAMP, 4 SLOT V	1	4.90 LBS	
15	GB-05605FT	5/8" X 6" GALV BOLT KIT FULL THREAD	4	0.59 LBS	INCLUDES BOLT, LOCK WASHER AND NUT
16	GWF05A	GALV FLAT WASHER HARDENED 5/8", 1.3OD	4	0.04 LBS	

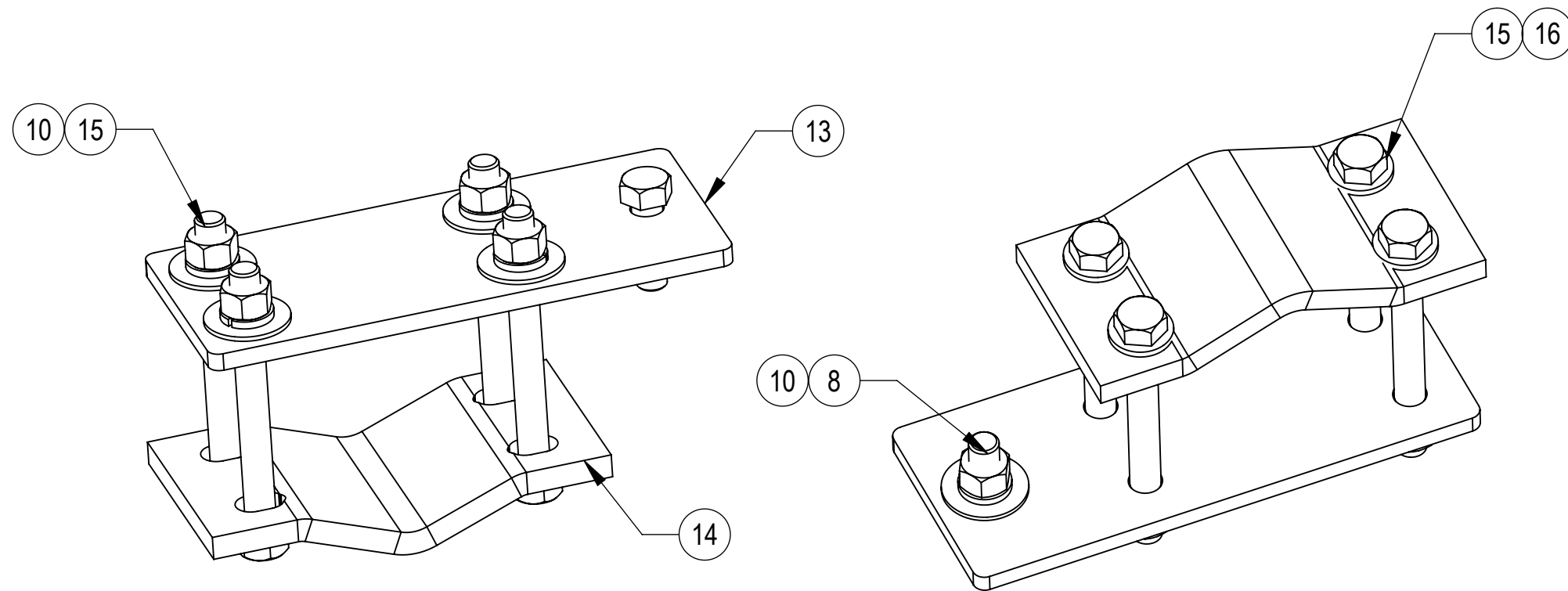

ADAPTER FOR PIPE CONNECTION

COMMSCOPE, INC. OF NORTH CAROLINA				
TITLE TIE BACK ASSEMBLY FOR LARGER LEG				
SIZE C	SCALE 1:7	DOCUMENT NO. VZWSMART-SFK1L		
DRAWING		VERSION	STATUS	REVISION
		00	RE	A
				SHEET 2 OF 2

4

3

2

1