

COLLAR MOUNT STANDOFF ADAPTER
ISOMETRIC VIEW

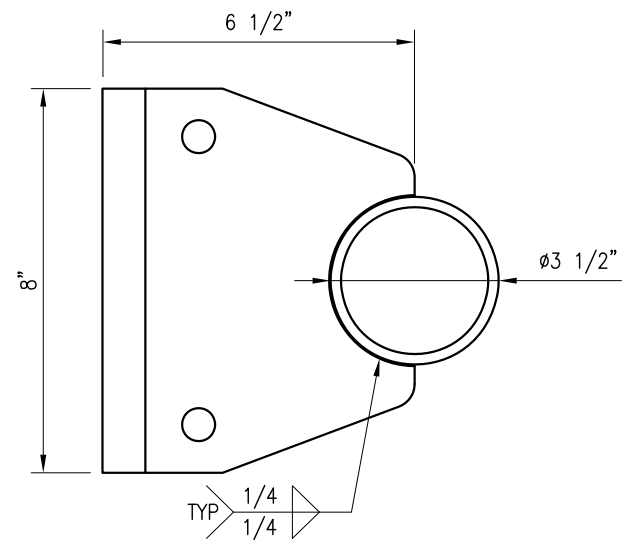

TOP VIEW

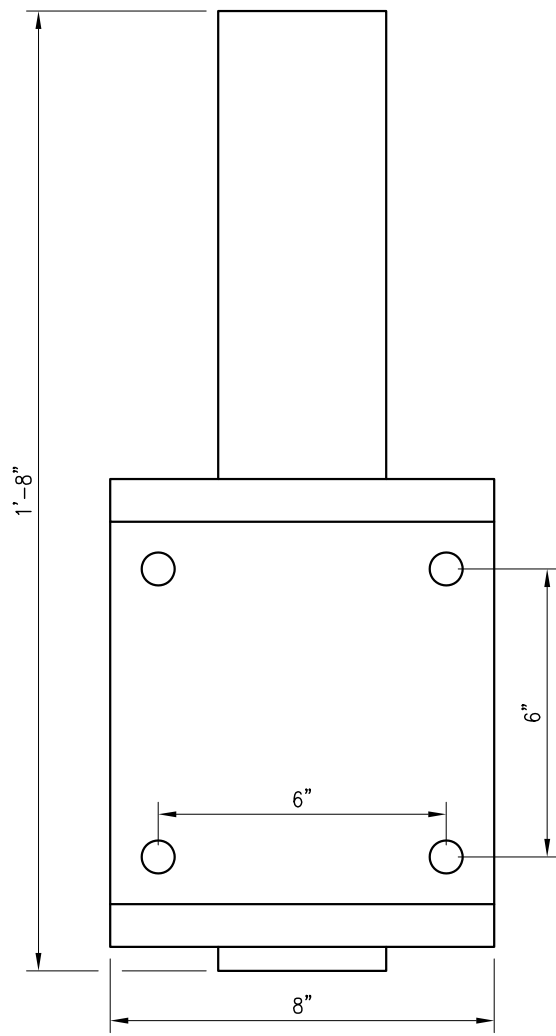

FRONT VIEW

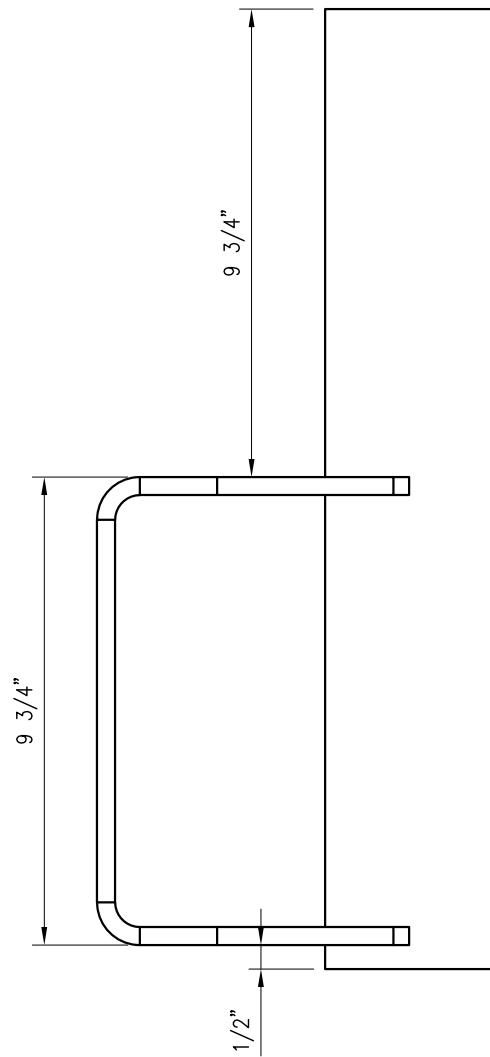

SIDE VIEW

NOTES:
1. HOT-DIPPED GALVANIZED PER ASTM A123.

TES-SS-PLK9 (COLLAR MOUNT STANDOFF ADAPTER)					
ITEM NO.	QTY.	PART NO.	DESCRIPTION	SHEET #	WT
1	1	P574-020-01	COLLAR PIPE STANDOFF - PLATE	PLK9-F1	15.58
2	1	P674-003-01	COLLAR PIPE STANDOFF - 20"	PLK9-F2	12.67
GALVANIZED WT					28

DRAWN BY: SP CHECKED BY: KW/SK

REV.	DESCRIPTION	BY	DATE
1	FIRST ISSUE	SP	07/18/23

SHEET TITLE:
TES-SS-PLK9 COLLAR
MOUNT STANDOFF
ADAPTER

SHEET NUMBER: TES-SS-PLK9 REV #: 0

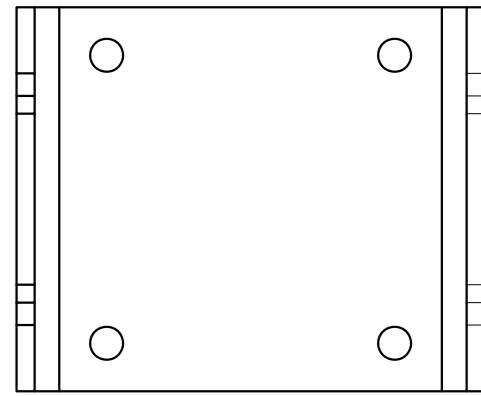

AFTER BENDING
FRONT VIEW

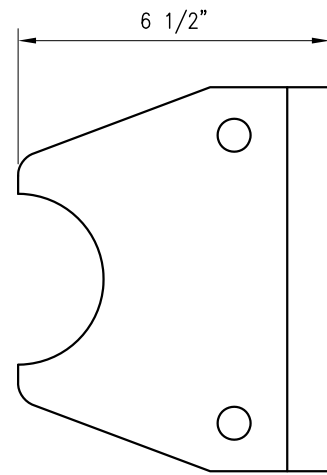

AFTER BENDING
SIDE VIEW

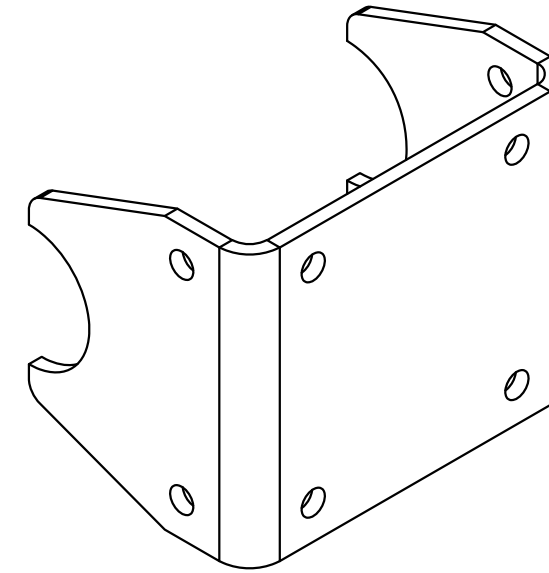

P574-020-01
ISOMETRIC VIEW

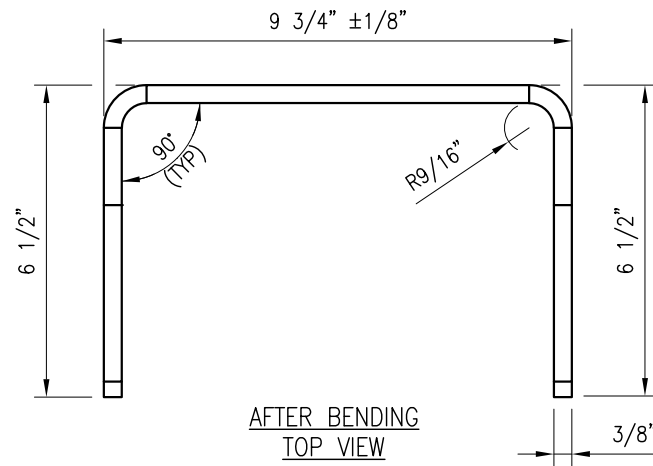

AFTER BENDING
TOP VIEW

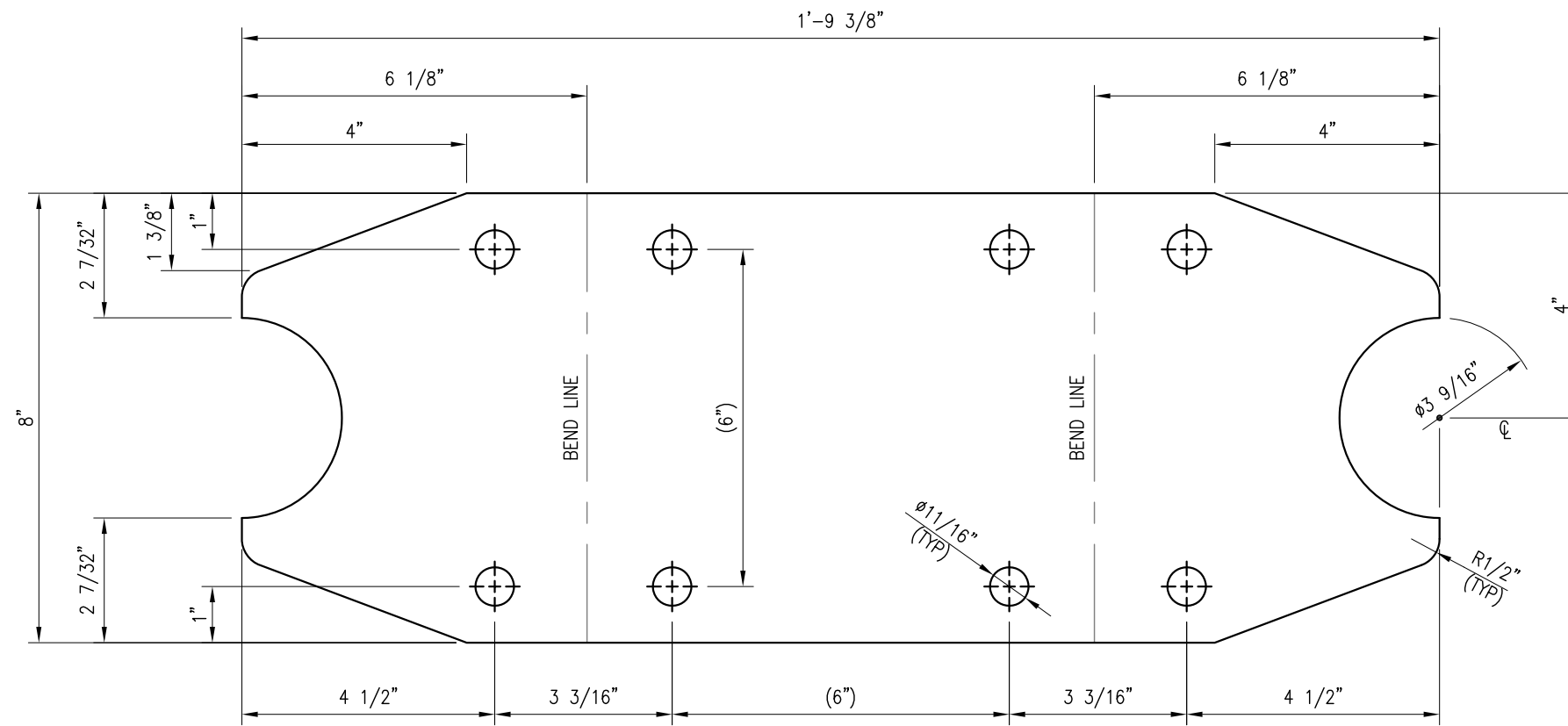

BEFORE BENDING
P574-020-01
PL 3/8" X 8" X 1'-9 3/8" A36 BENT PLATE
(14.39 LBS)

NOTES:
1. HOT-DIPPED GALVANIZED PER ASTM A123.

DRAWN BY: SP CHECKED BY: KW/SK

REV.	DESCRIPTION	BY	DATE
1	FIRST ISSUE	SP	07/18/23

SHEET TITLE:

FABRICATION DETAILS

SHEET NUMBER: PLK9-F1 REV #: 0

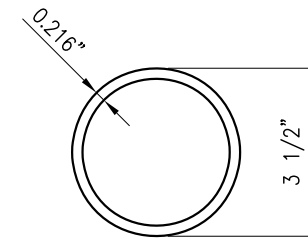
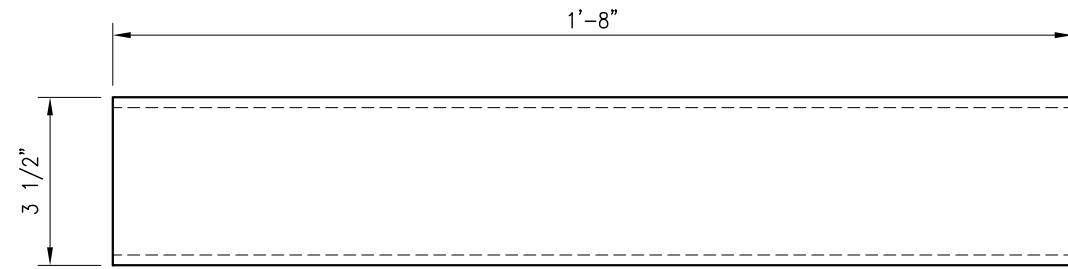

P674-003-01
 PIPE 3 SCH40 (3.50" O.D. X 0.216" THK) X 1'-8" A53 GR. B
 (12.92 LBS)

NOTES:
 1. HOT-DIPPED GALVANIZED PER ASTM A123.

DRAWN BY: SP CHECKED BY: KW/SK

REV.	DESCRIPTION	BY	DATE
1	FIRST ISSUE	SP	07/18/23

SHEET TITLE:

FABRICATION DETAILS

SHEET NUMBER: REV #:

PLK9-F2 0