

4

3

2

1

- 1.0 GENERAL NOTES
 - 1.1 ALL METRIC DIMENSIONS ARE IN BRACKETS [X. X]
 - 1.2 FOR PATENT INFO: <https://www.cs-pat.com>
- 2.0 DESIGN NOTES
 - 2.1 ANY HAZARDS OR OBSTRUCTIONS TO THE CLIMBING FACILITY AND SAFETY CLIMB MUST BE IDENTIFIED PRIOR TO INSTALLING THE APPURTENANCE. ADDITIONAL PRODUCTS MAY BE REQUIRED TO MAINTAIN THE INTEGRITY OF THE SAFETY CLIMB. DURING INSTALLATION, TEMPORARY AND/OR PERMANENT PRECAUTIONARY MEASURES SHOULD BE TAKEN TO PRESERVE THE CLIMBING FACILITY AND/OR SAFETY CLIMB.
- 3.0 MANUFACTURING/SPECIAL REQUIREMENTS
 - 3.1 TIGHTEN ALL BOLTS SECURING FLAT PLATES BY THE TURN-OF-NUT METHOD. TIGHTEN ALL U-BOLTS USING TURN-OF-NUT METHOD WITH ATTENTION TO LEAVE EQUAL DISTANCE AND EQUAL FORCE ON EACH LEG OF THE U-BOLT.
- 4.0 TEST
- 5.0 PACKAGING
 - 5.1 PACKAGING SHALL MEET COMMSCOPE REQUIREMENTS PER DOCUMENT IS-PL-3005
 - 5.2 PRINTED DOCUMENT TO BE PLACED INSIDE POLYBAG AND THEN IN SHIPPING CONTAINER
 - 5.3 EXTRA HARDWARE MAY BE SUPPLIED, BAGGED AND SHIPPED

REVISIONS			
REV.	DESCRIPTION	DATE	APPROVED
A	INITIAL RELEASE	YMENG 06MAY24	YW1047 40195000CMO
B	MTC4173-1000-00 WAS MTC4045C01	YMENG 29SEP24	YW1047 40205381CMO

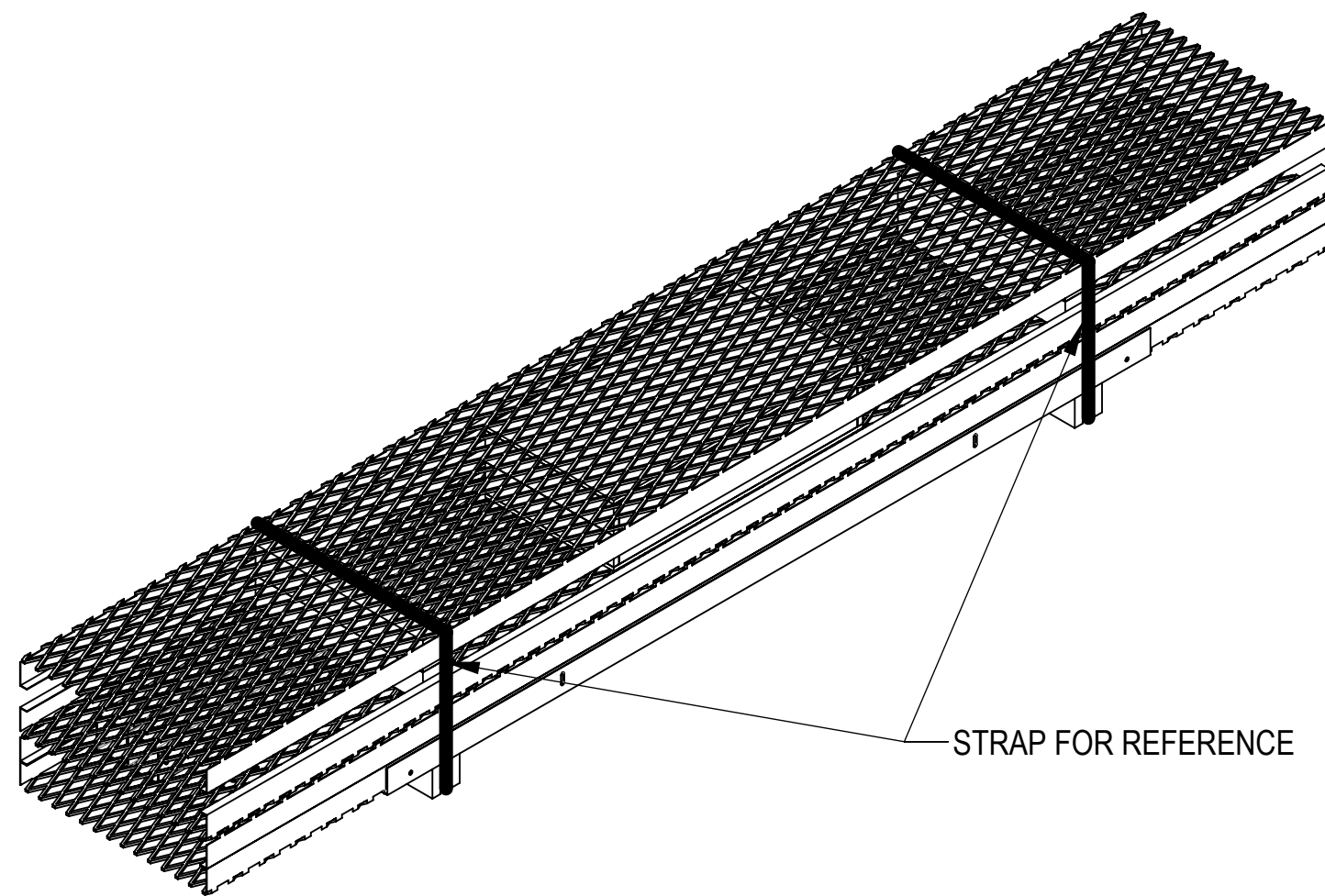
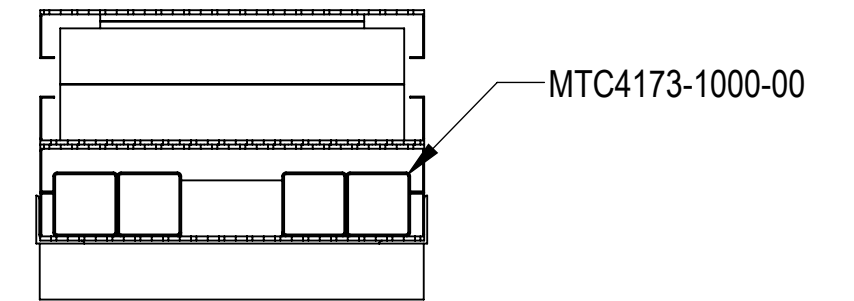
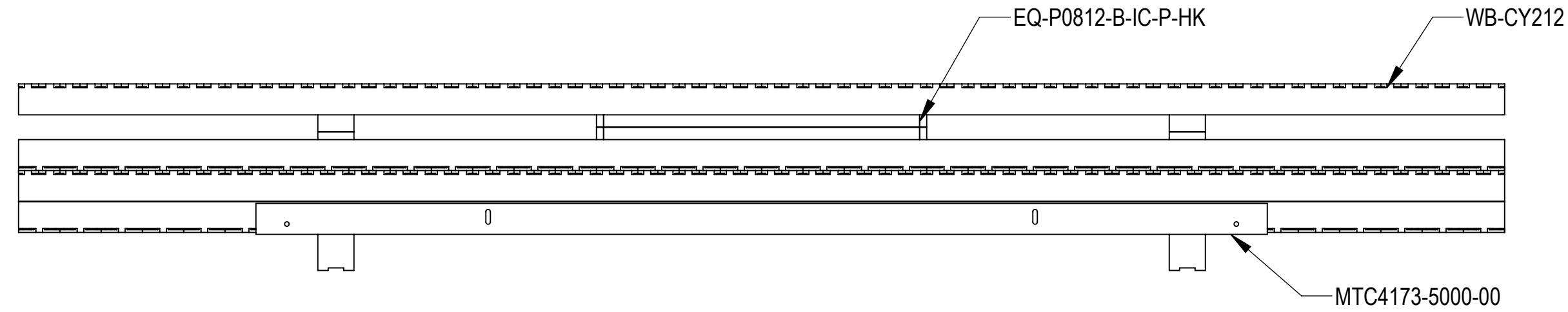

PACKAGE

COMMSCOPE, INC. OF NORTH CAROLINA											
TOLERANCES						SAP MATERIAL MASTER					
1 PLACE .X[X] ± 0.2[6.3]			3 PLACE .XXX[X] ± 0.060[1.5]			EQ-P0812-B-IC-P					
2 PLACE .XX[X] ± 0.12[3.0]			ANGLES ± 2°								
FINISH						MATERIAL					
UNLESS OTHERWISE SPECIFIED DIMENSIONS ARE IN INCHES INTERPRET PER ANSI Y 14.5M-1994	NAME	DATE	TITLE								
	CE YMENG	06MAY24	ICE CANOPY FOR EQ-P0812-B								
	RW YMENG	09/29/2024									
	AD YW1047	09/29/2024									
	RE YMENG	10/23/2024									
ECN 40205381CMO			SCALE	DOCUMENT NO.							
			1:24	EQ-P0812-B-IC-P							
SIZE	Auth Group	INSL	MODEL			DRAWING			SHEET		
C			VERSION	STATUS	REVISION	VERSION	STATUS	REVISION	1 OF 4		
			01	RE	B	01	RE	B			

DENSITY		lbs/in ³
MASS	832.07	lbs
VOLUME	2938.07	in ³
SURFACE AREA	46171.50	in ²
HEIGHT		
LENGTH		
WIDTH		

4

3

2

1

4

3

2

1

D

D

C

C

B

B

A

A

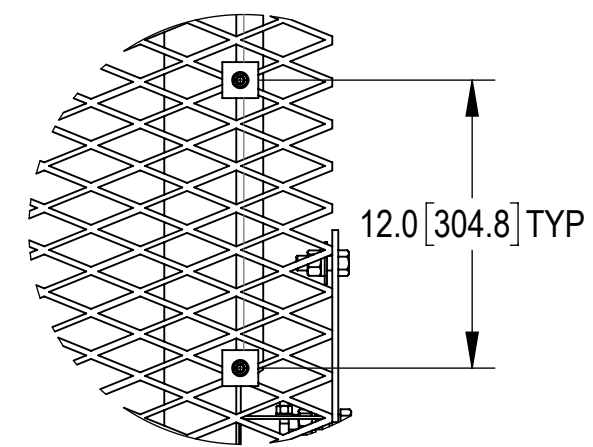
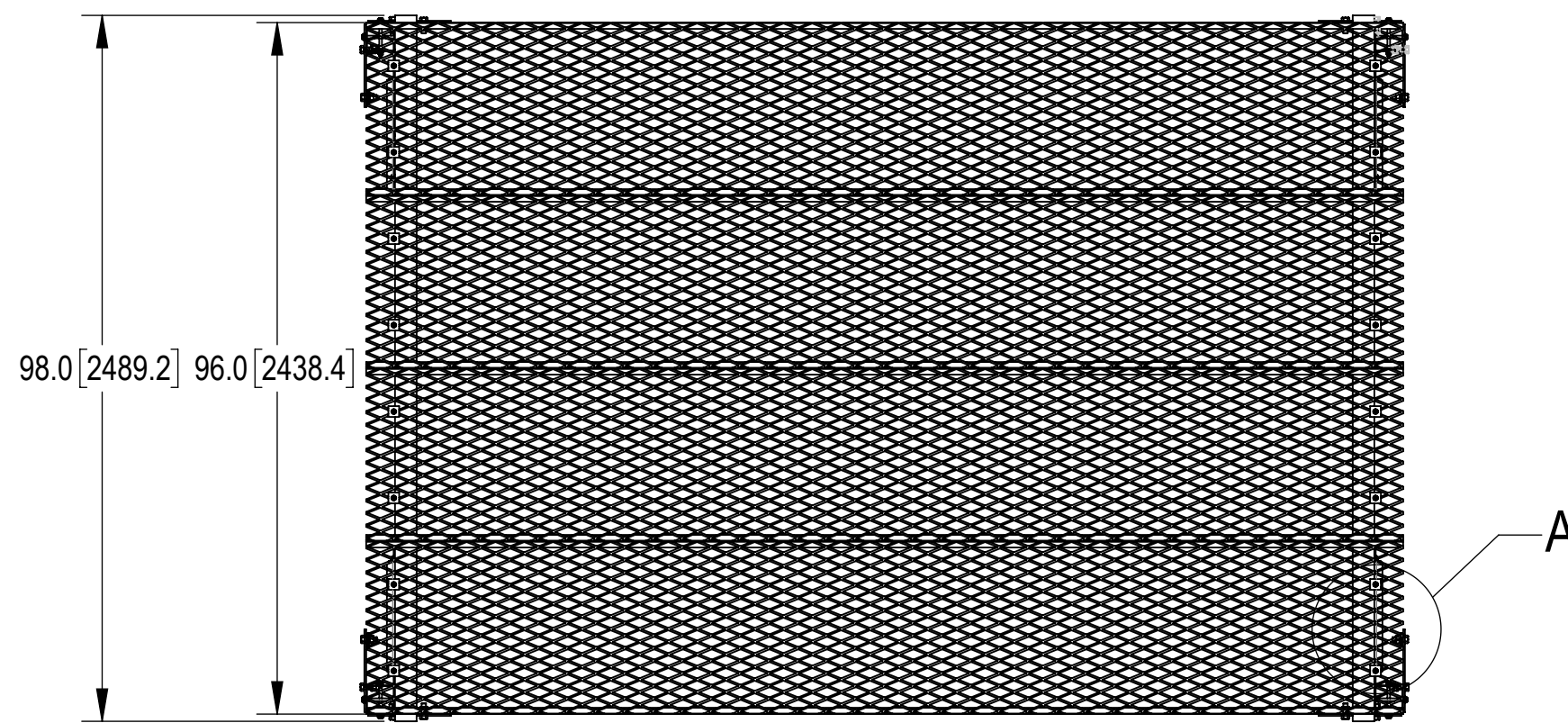
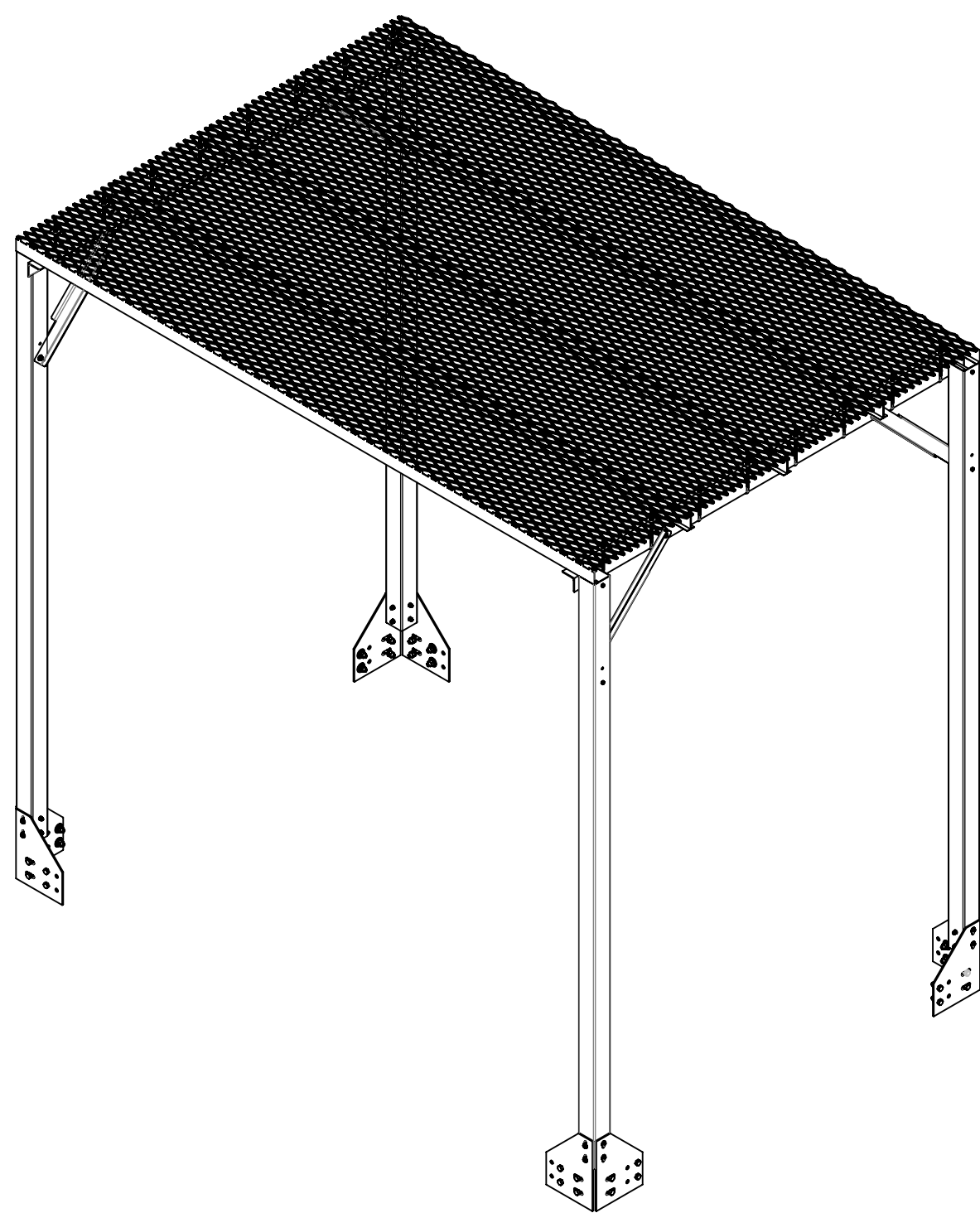

DETAIL A
SCALE 1:8

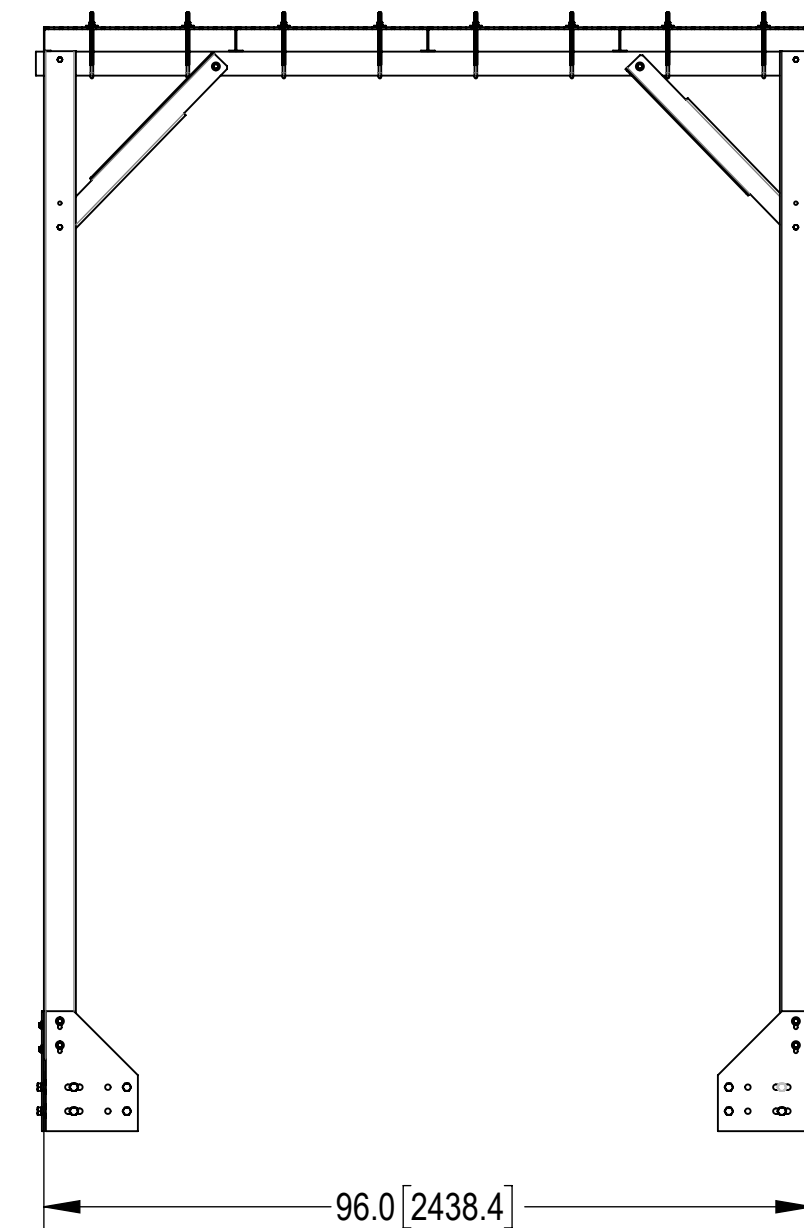
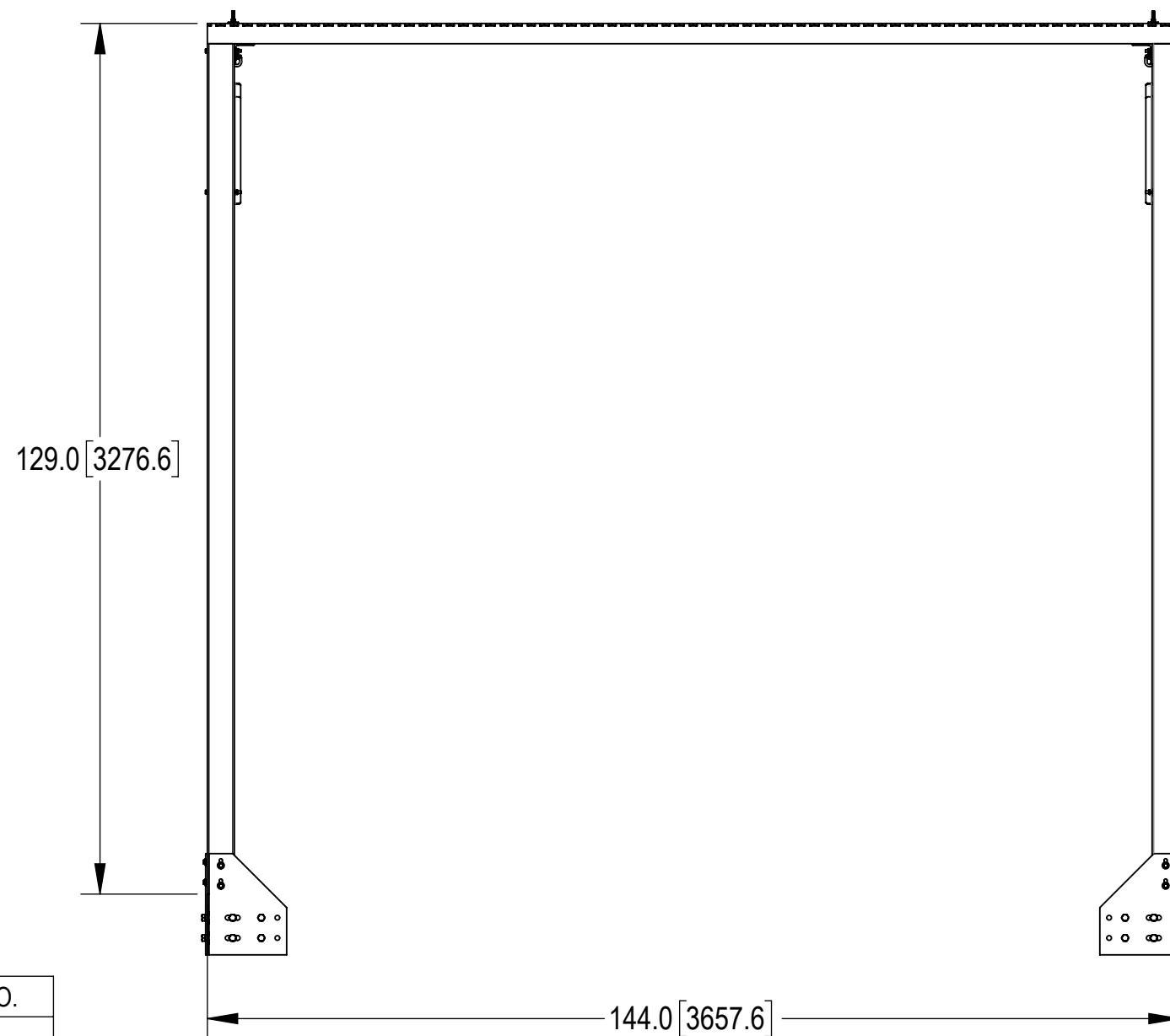

COMPONENT PART NUMBERS PROVIDED FOR ASSEMBLY PURPOSES;
INDIVIDUAL COMPONENTS MAY BE SHIPPED AS PARTS WITHIN AN INCLUDED KIT.

ITEM	PART NO.	DESCRIPTION	QTY.	WEIGHT	NOTE NO.
1	WB-CY212	SAFETY GRATING, 24" X 144"	4	96.36 LBS	
2	MTC4173-1000-00	POST, 4X4 SQUARE TUBE, 126"	4	64.74 LBS	
3	MTC4173-5000-00	8' ICE SHIELD SUPPORT BRACKET	2	30.44 LBS	
4	MTC4130-3000-00	CANOPY BRACE	4	6.52 LBS	
5	GJB0380	8" GALV J-BOLT KIT	16	0.23 LBS	
6	MT-387	SQUARE WASHER 1-1/2" X 1-1/2" W/ 7/16 HOLE	16	0.11 LBS	
7	MTC4169-2000-00	PLATE, CANOPY LEG SUPPORT	8	9.59 LBS	
8	GB-03505	3/8" X 5" GALV BOLT KIT	24	0.17 LBS	
9	GB-03125	3/8" X 1-1/4" GALV BOLT KIT	4	0.06 LBS	
10	GB-05165	5/8" X 1-3/4" GALV BOLT KIT	16	0.24 LBS	
11	GWF-03	3/8" GALV FLAT WASHER	28	0.01 LBS	
12	GWF-05	5/8" GALV FLAT WASHER, 1.70D	16	0.06 LBS	
13	GN-03	3/8" GALV HEX NUT	16	0.02 LBS	
14	GWL-03	3/8" GALV LOCK WASHER	16	0.01 LBS	
15	GB-05225	5/8" X 2-1/4" GALV BOLT KIT	16	0.28 LBS	

COMMSCOPE, INC. OF NORTH CAROLINA				
TITLE ICE CANOPY FOR EQ-P0812-B				
SIZE C	SCALE 1:24	DOCUMENT NO. EQ-P0812-B-IC-P		
DRAWING		VERSION	STATUS	REVISION
SHEET 2 OF 4		01	RE	B

© 2024 CommScope, Inc. Confidential

4

3

2

1

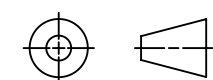

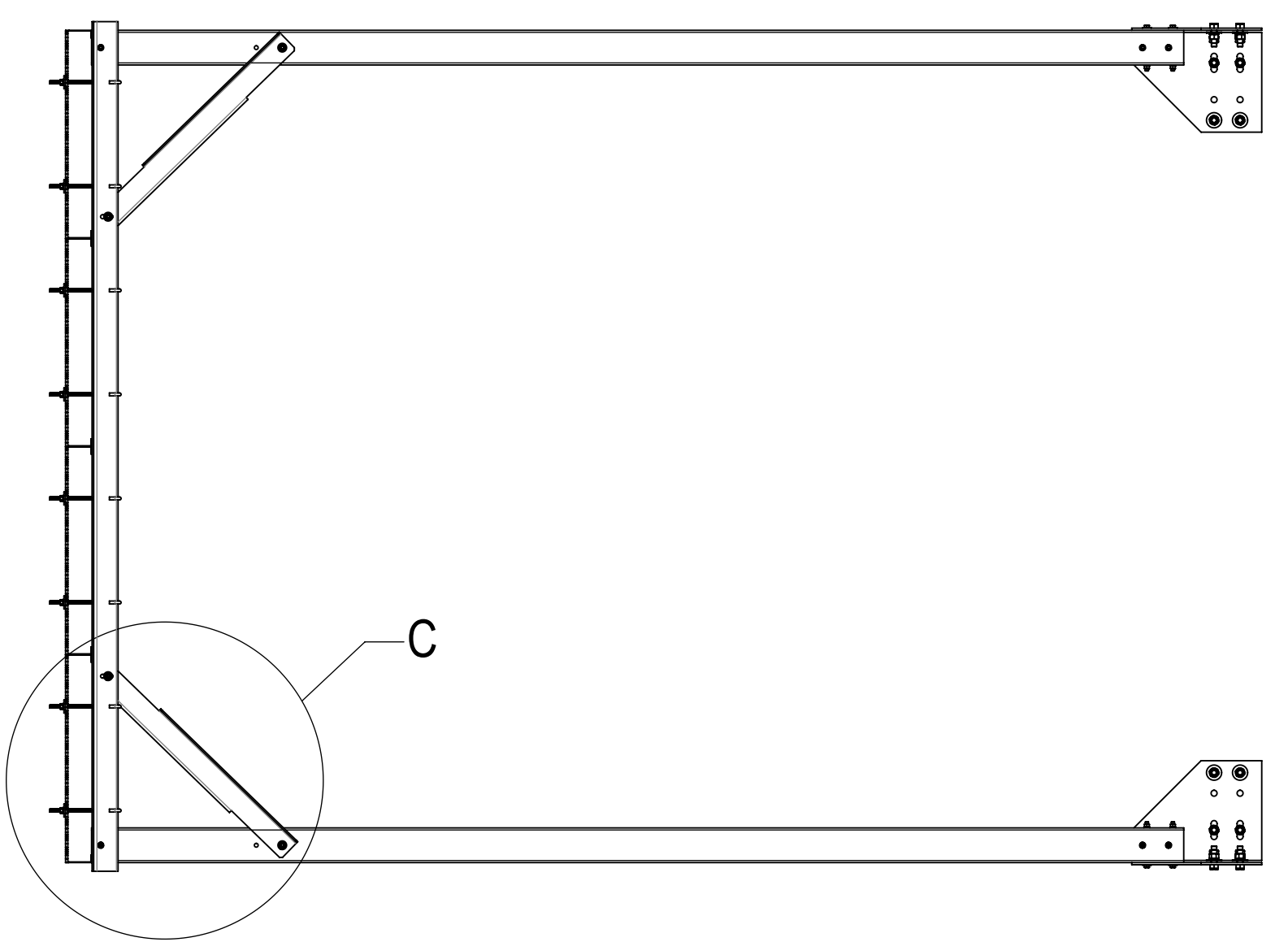
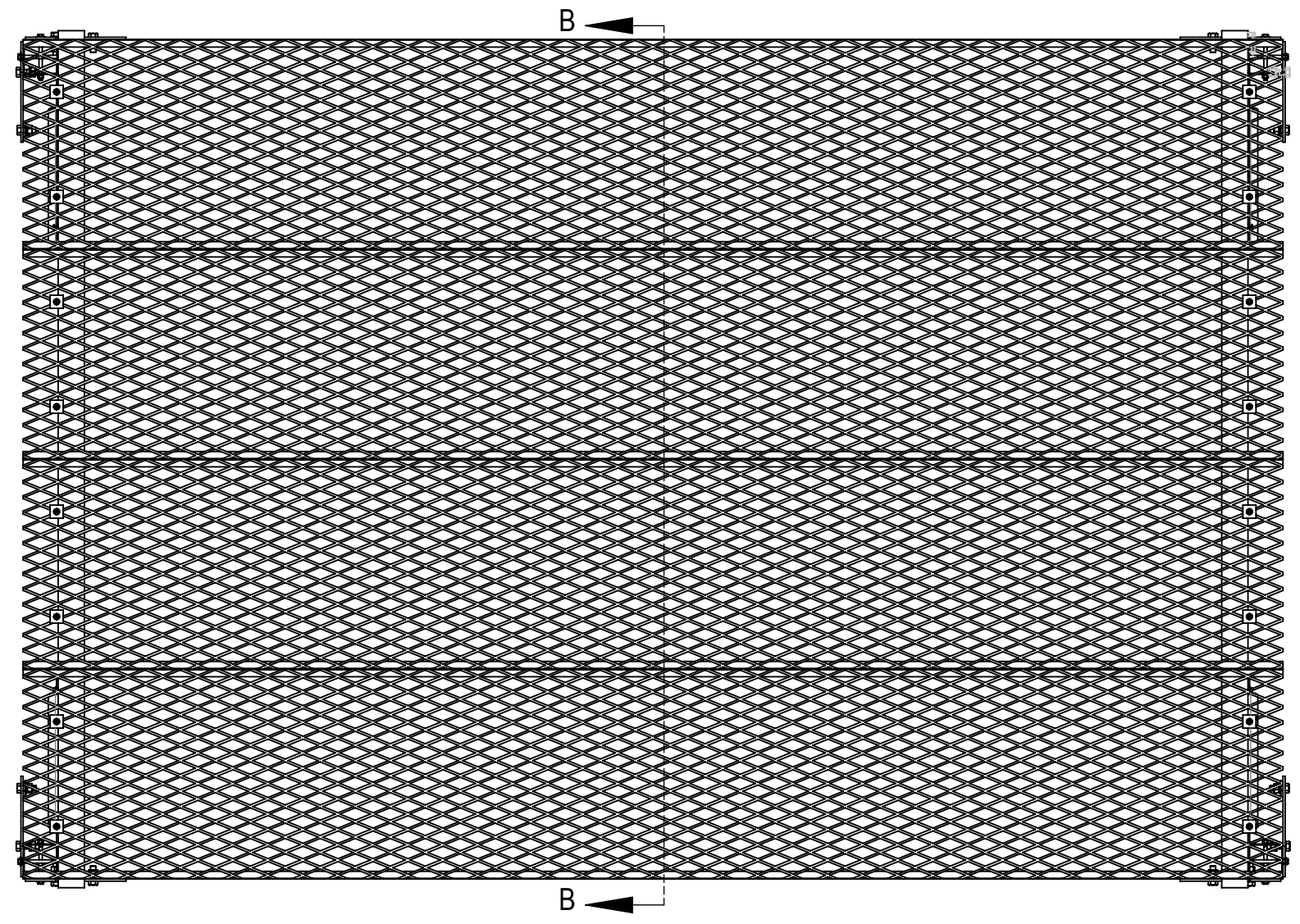

SECTION B-B
SCALE 1 : 18

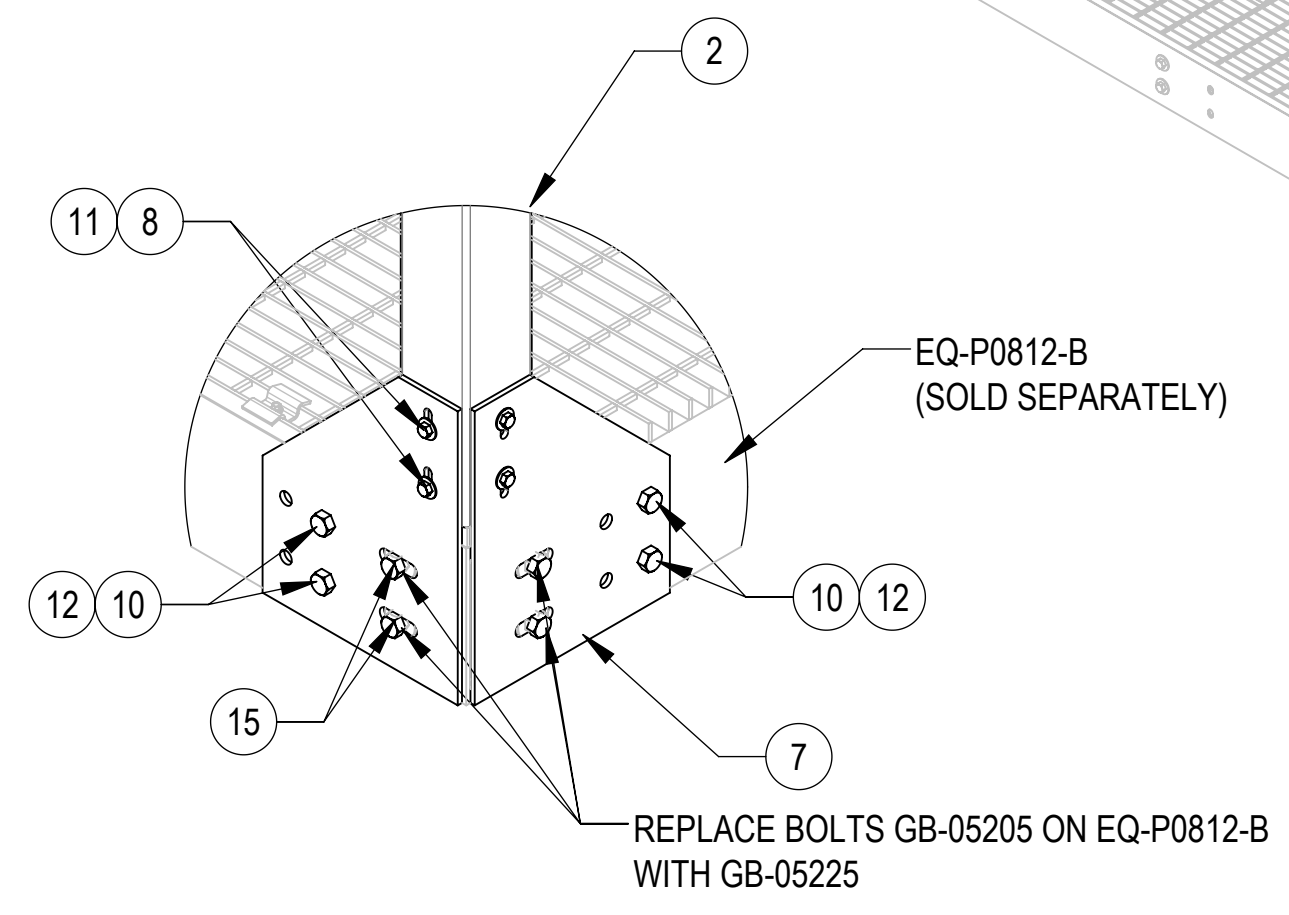
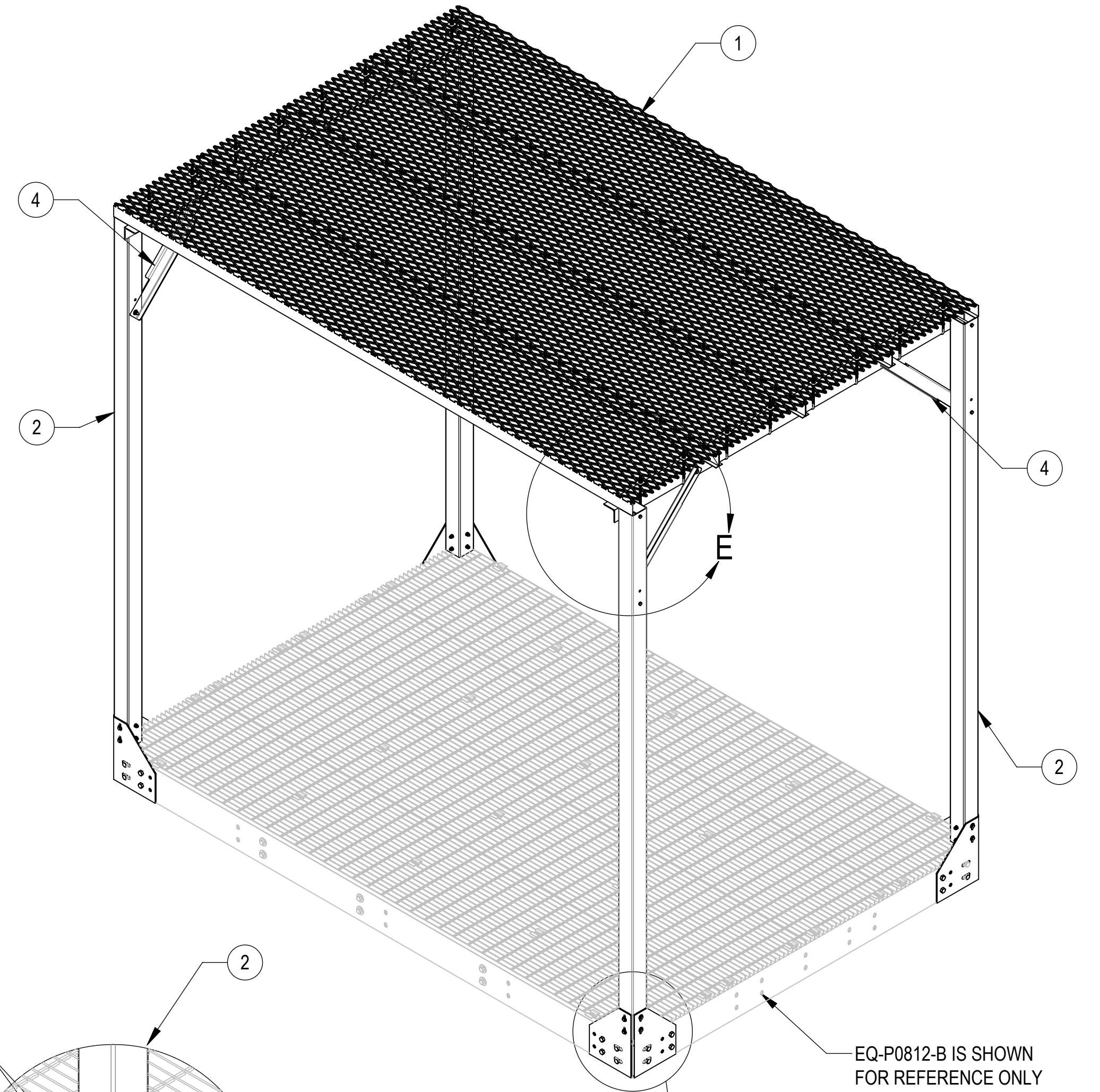

DETAIL D
SCALE 1 : 8
(4 PLACES)

COMMSCOPE, INC. OF NORTH CAROLINA				
TITLE ICE CANOPY FOR EQ-P0812-B				
SIZE C	SCALE 1:24	DOCUMENT NO. EQ-P0812-B-IC-P		
		DRAWING		SHEET 3 OF 4
		VERSION 01	STATUS RE	

4

3

2

1

D

D

C

C

B

B

A

A

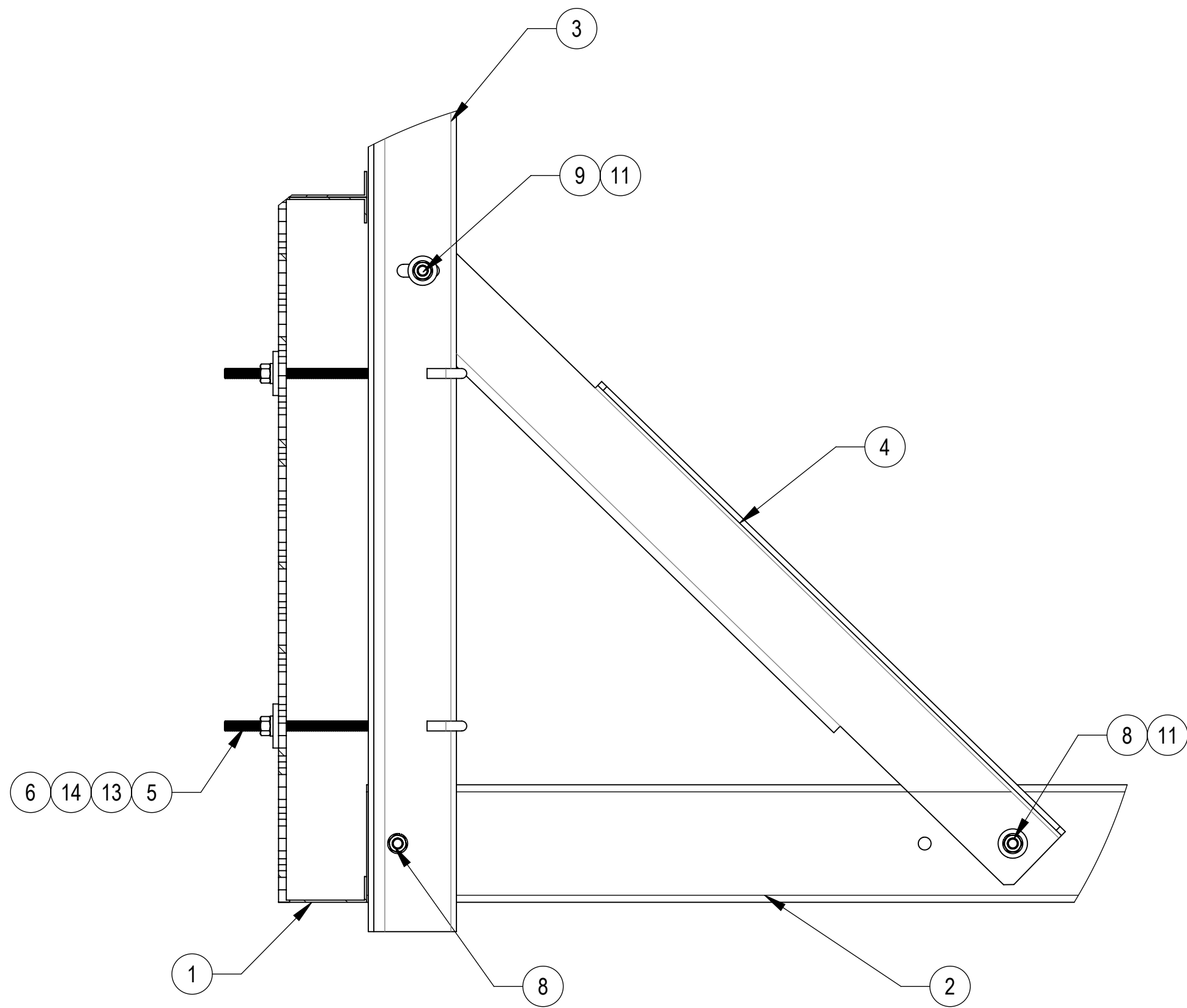

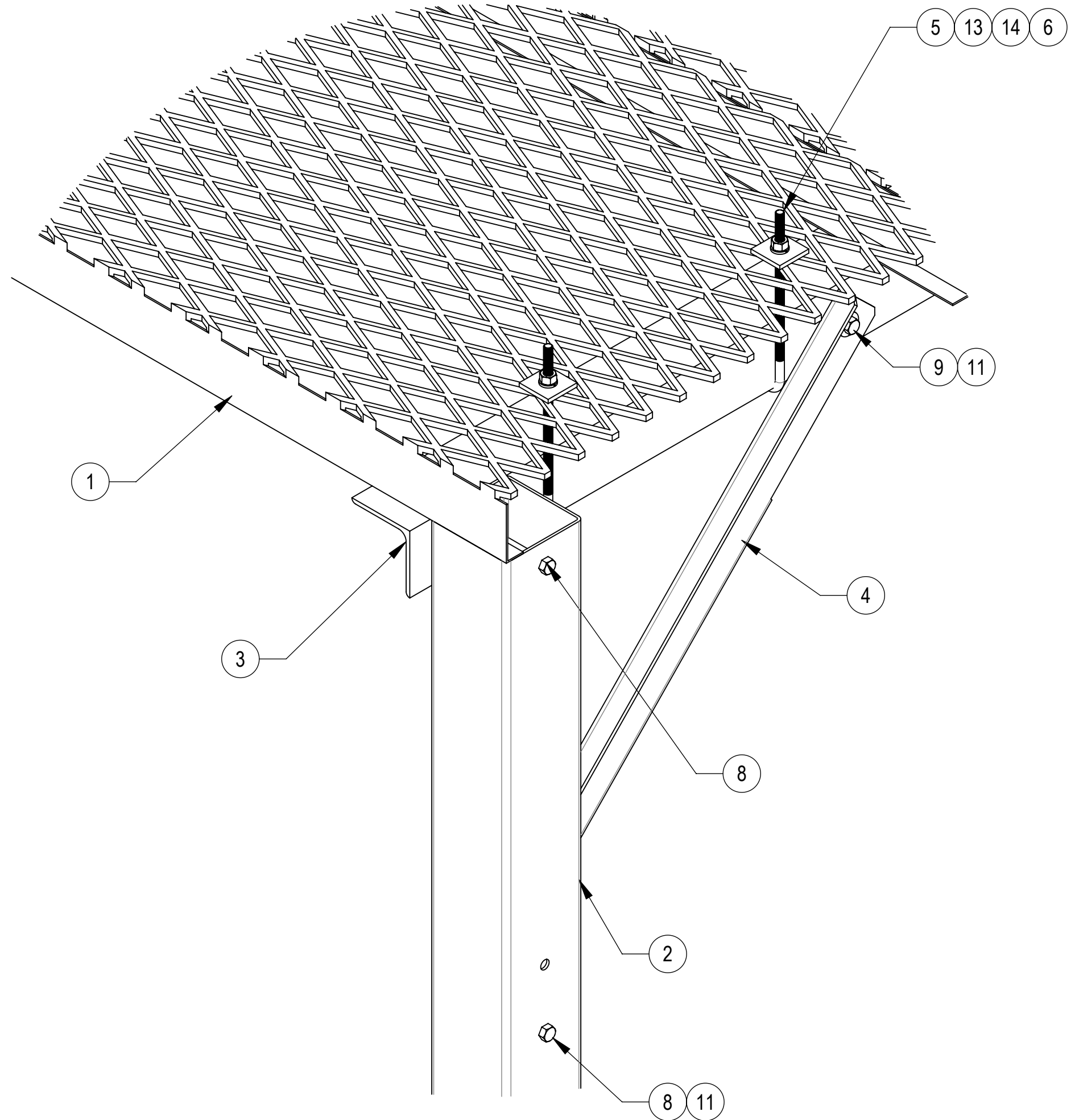

DETAIL C
SCALE 1 : 4



DETAIL E
SCALE 1 : 4

© 2024 CommScope, Inc. Confidential

COMMSCOPE, INC. OF NORTH CAROLINA					
TITLE ICE CANOPY FOR EQ-P0812-B					
SIZE C	SCALE 1:24	DOCUMENT NO. EQ-P0812-B-IC-P			
 		DRAWING			SHEET 4 OF 4
		VERSION 01	STATUS RE	REVISION B	