

- 1.0 GENERAL NOTES
 1.1 ALL METRIC DIMENSIONS ARE IN BRACKETS [X.X]
 1.2 FOR PATENT INFO: <https://www.cs-pat.com>
 2.0 DESIGN NOTES
 2.1 USE DRAWING MC-RMHD-1545-4 TO ASSEMBLE RING MOUNT
 2.2 ANY HAZARDS OR OBSTRUCTIONS TO THE CLIMBING FACILITY AND SAFETY CLIMB MUST BE IDENTIFIED PRIOR TO INSTALLING THE APPURTENANCE. ADDITIONAL PRODUCTS MAY BE REQUIRED TO MAINTAIN THE INTEGRITY OF THE SAFETY CLIMB. DURING INSTALLATION, TEMPORARY AND/OR PERMANENT PRECAUTIONARY MEASURES SHOULD BE TAKEN TO PRESERVE THE CLIMBING FACILITY AND/OR SAFETY CLIMB.
 3.0 MANUFACTURING/SPECIAL REQUIREMENTS
 3.1 TIGHTEN ALL BOLTS SECURING FLAT PLATES BY THE TURN-OF-NUT METHOD. TIGHTEN ALL U-BOLTS USING TURN-OF-NUT METHOD WITH ATTENTION TO LEAVE EQUAL DISTANCE AND EQUAL FORCE ON EACH LEG OF THE U-BOLT.
 4.0 TEST
 5.0 PACKAGING
 5.1 PACKAGING SHALL MEET COMMSCOPE REQUIREMENTS PER DOCUMENT IS-PL-3005
 5.2 PRINTED DOCUMENT TO BE PLACED INSIDE POLYBAG AND THEN IN SHIPPING CONTAINER
 5.3 EXTRA HARDWARE MAYBE SUPPLIED, BAGGED AND SHIPPED

REVISIONS			
REV.	DESCRIPTION	DATE	APPROVED
A	INITIAL RELEASE	YMENG 19OCT21	BA1025 14658
B	MCPM-2005-00 WAS MCPM-2000-00, MT-219N-H WAS MT21703 KIT, GB-0524A WAS GB-0522A, ALL U-BOLTS CHANGED TO GUB-4352	JYANG4 26SEP22	BA1025 40156827CMO

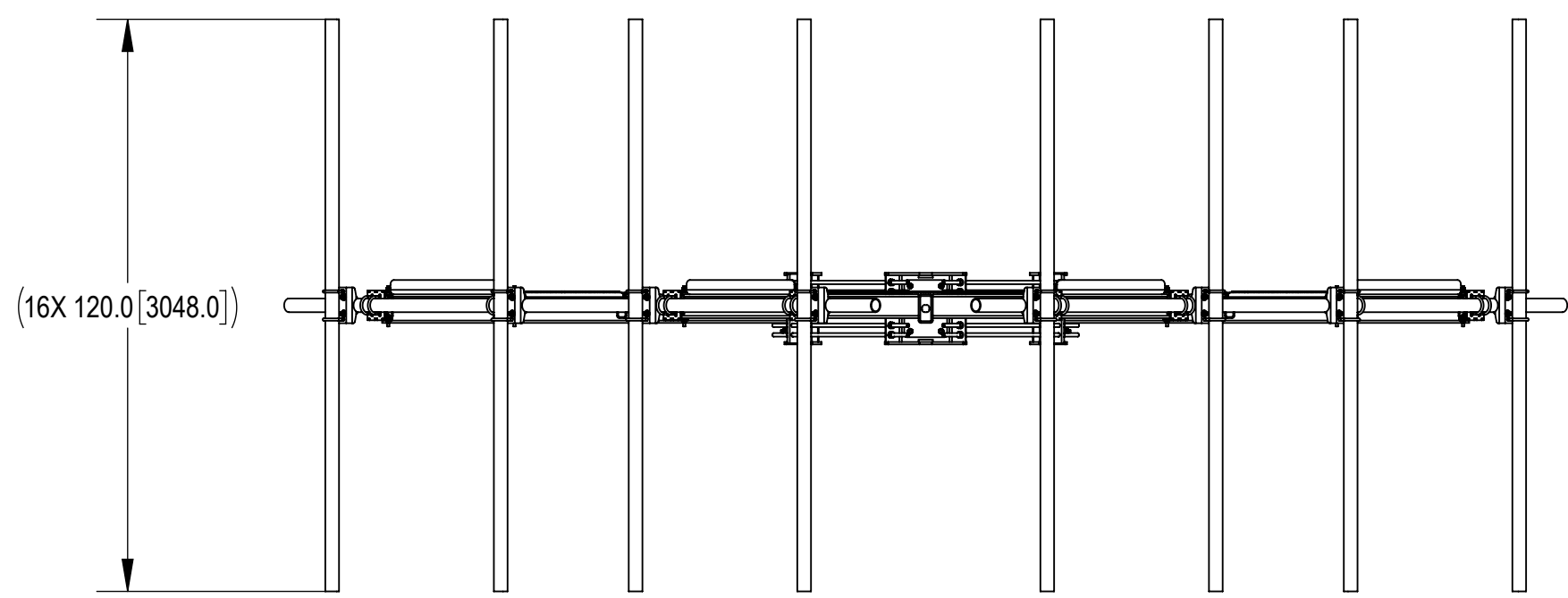
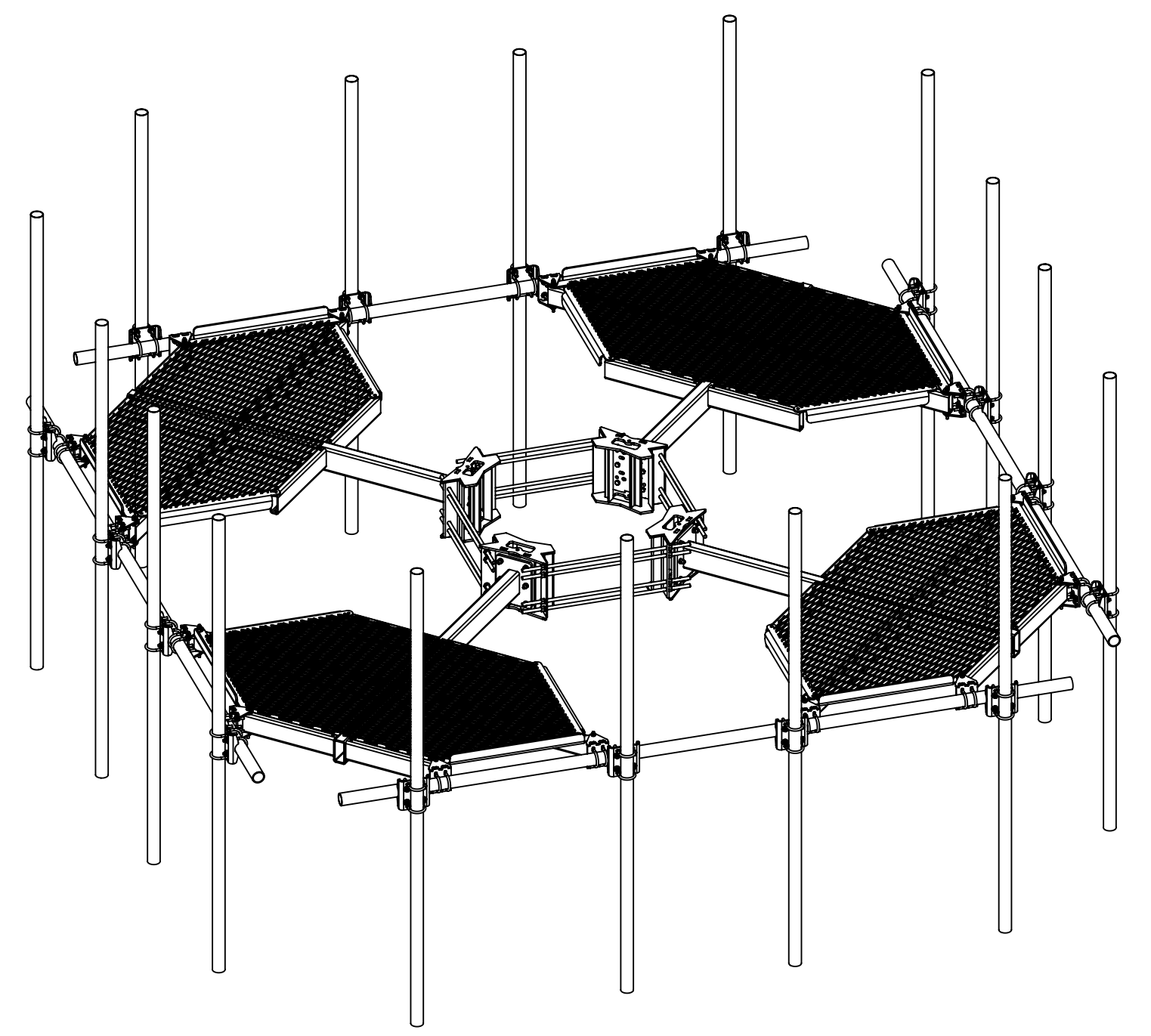
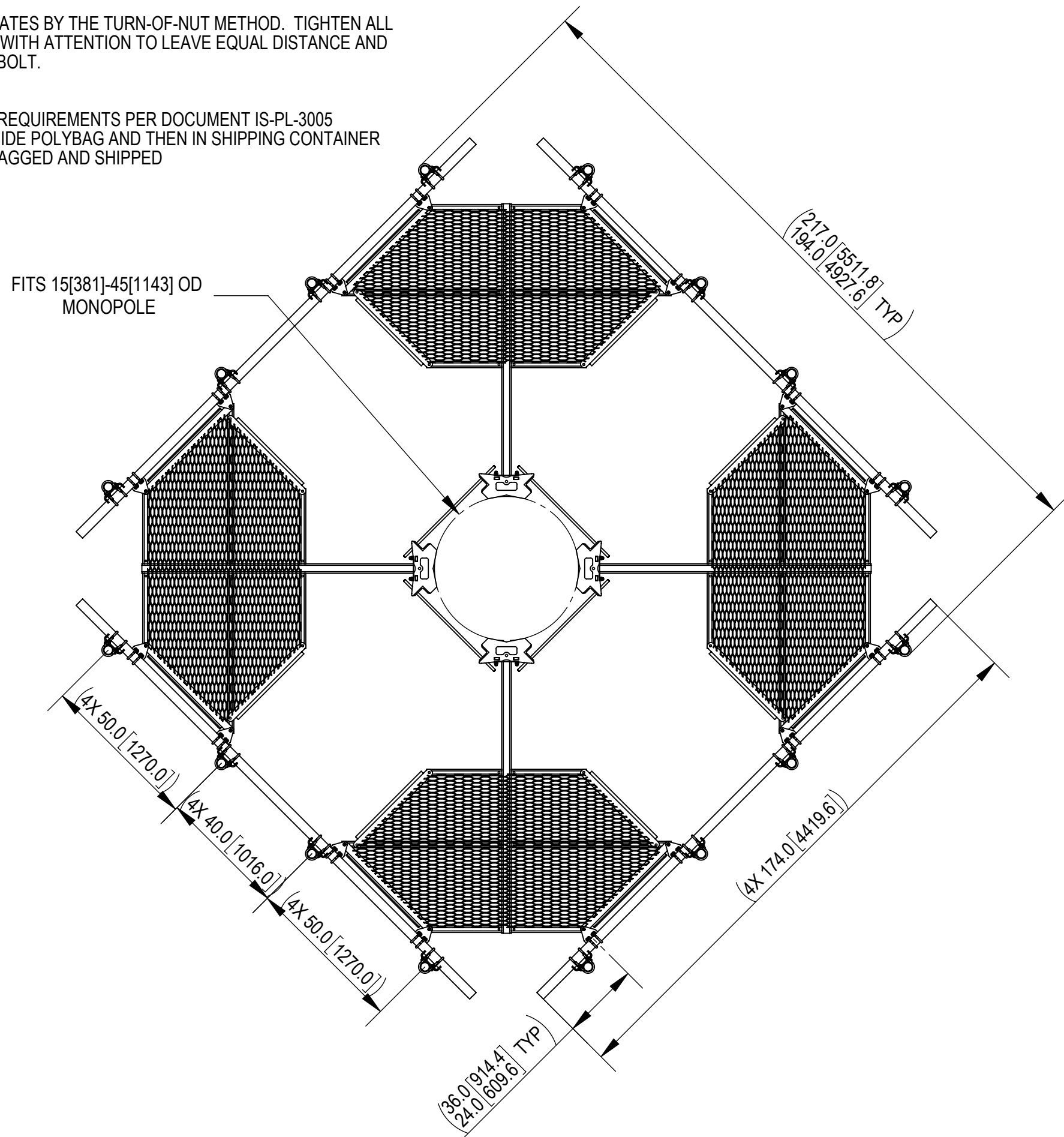

DENSITY	3501.74	lbs/in ³
MASS	3501.74	lbs
VOLUME	13436.56	in ³
SURFACE AREA	118033.35	in ²
HEIGHT	120[3048]	
LENGTH	217[5512]	
WIDTH	217[5512]	

© 2022 CommScope, Inc. Confidential

COMMSCOPE, INC. OF NORTH CAROLINA

TOLERANCES		SAP MATERIAL MASTER	
1 PLACE .X[X] ± 0.25[6.3]	3 PLACE .XXX[X] ± 0.060[1.5]	MC-PM14M4-16-120	
2 PLACE .XX[X] ± 0.12[3.0]	ANGLES ± 2°		
FINISH		MATERIAL	
UNLESS OTHERWISE SPECIFIED DIMENSIONS ARE IN INCHES INTERPRET PER ANSI Y 14.5M-1994		TITLE	
CE YMENG 10/19/2021	AD BA1025 10/13/2022	ATLAS4, 14' FP, (16)2.88" X120"AP	
RW YMENG 10/10/2022	RE YMENG 01/11/2023	SCALE	DOCUMENT NO.
ECN 40156827CMO		1:48	MC-PM14M4-16-120
SIZE	Auth Group INSL	MODEL	
C		VERSION	DRAWING
		01	RE
		REVISION	VERSION
		B	01
		REVISION	STATUS
		B	RE
			REVISION
			B
			SHEET
			1 OF 7

4

3

2

1

D

D

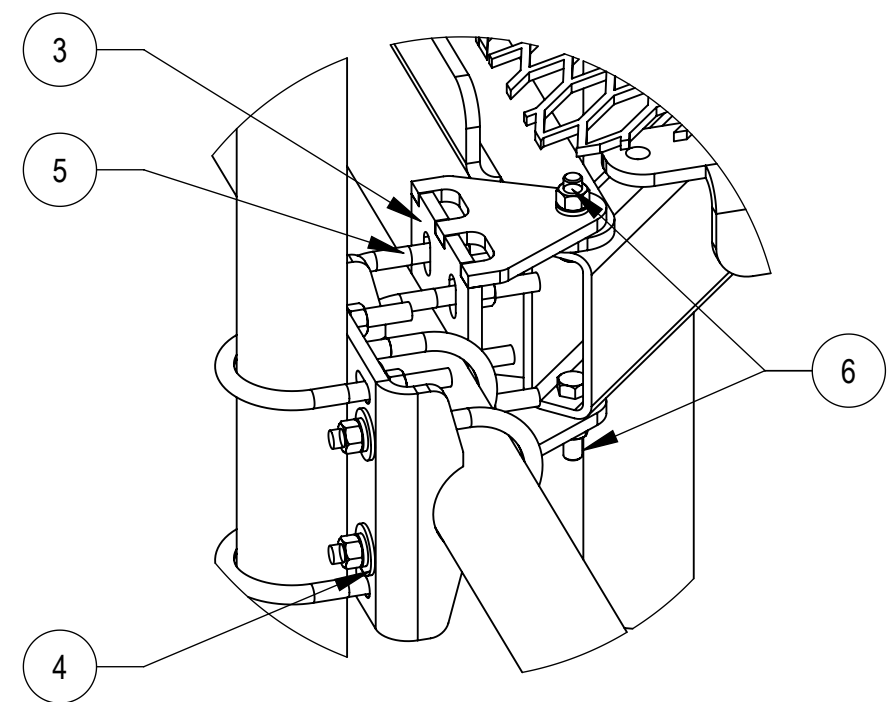

DETAIL A
SCALE 1 : 5

C

C

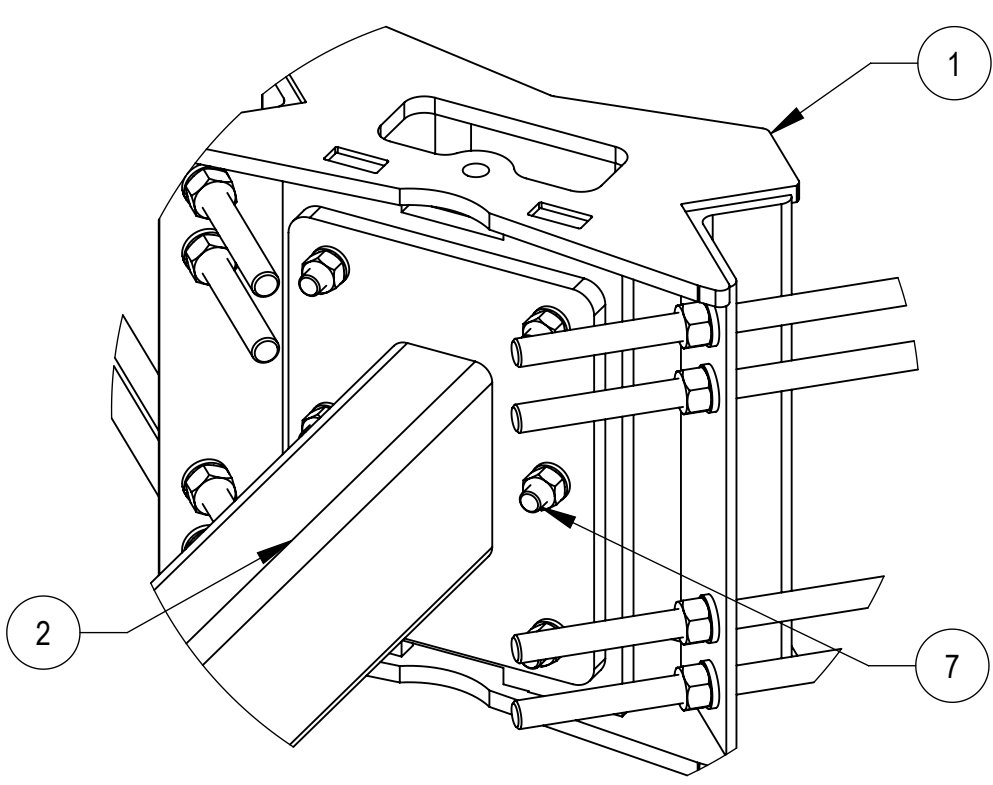

DETAIL B
SCALE 1 : 5

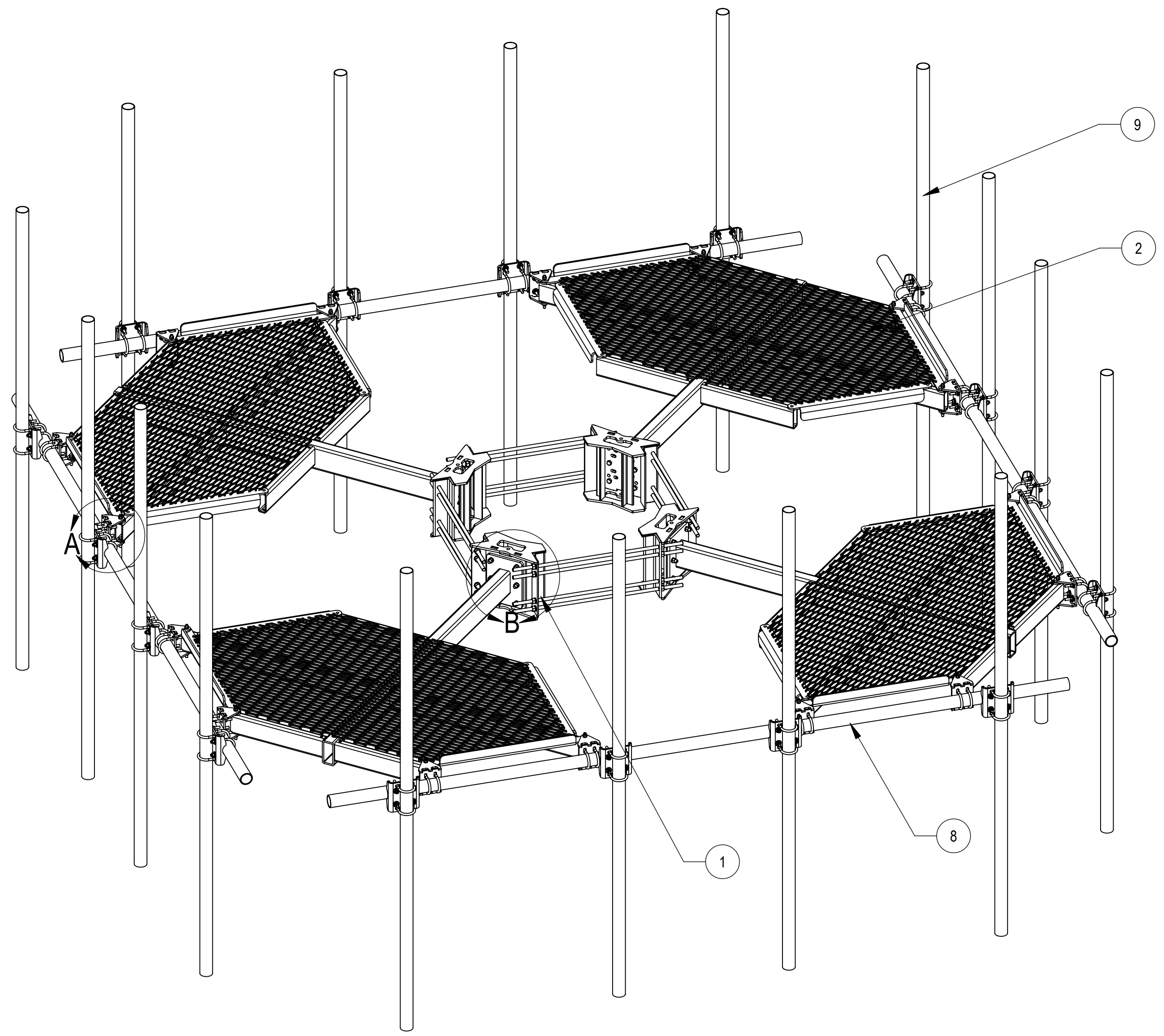

COMPONENT PART NUMBERS PROVIDED FOR ASSEMBLY PURPOSES;
INDIVIDUAL COMPONENTS MAY BE SHIPPED AS PARTS WITHIN AN INCLUDED KIT.

ITEM	PART NO.	DESCRIPTION	QTY.	WEIGHT	NOTE NO.
1	MC-RMHD-1545-4	4 SECTOR RING MOUNT, 15"-45" POLE	1	386.57LBS	
2	MC-PM4-2000	WELDMENT, CO-LOCATION PLATFORM	4	477.02 LBS	
3	MCPM-2005-00	BRACKET, PIPE MOUNTING	16	5.47 LBS	
4	MT-219N-H	SADDLE PIPE MOUNTING KIT, 2-7/8" OD	16	10.61 LBS	
5	GUB-4352	1/2" X 3" X 5-1/4" GALV U-BOLT	32	0.71 LBS	
6	GB-04205	1/2" X 2" GALV BOLT KIT	32	0.16 LBS	
7	GB-0524A	5/8" X 2-1/2" GALV BOLT KIT (A325)	24	0.30 LBS	
8	MT-546-174	PIPE, 2.875"OD X 174"	4	84.30 LBS	
9	MT546120120	PIPE, 2.875"OD X 120"	16	35.44 LBS	

⚠
⚠
⚠
⚠

COMMSCOPE, INC. OF NORTH CAROLINA				
TITLE ATLAS4, 14' FP,(16)2.88" X120"AP				
SIZE C	SCALE 1:48	DOCUMENT NO. MC-PM14M4-16-120		
DRAWING		VERSION	STATUS	REVISION
		01	RE	B
				SHEET 2 OF 7

© 2022 CommScope, Inc. Confidential

4

3

2

1

A

A



4

3

2

1

1X

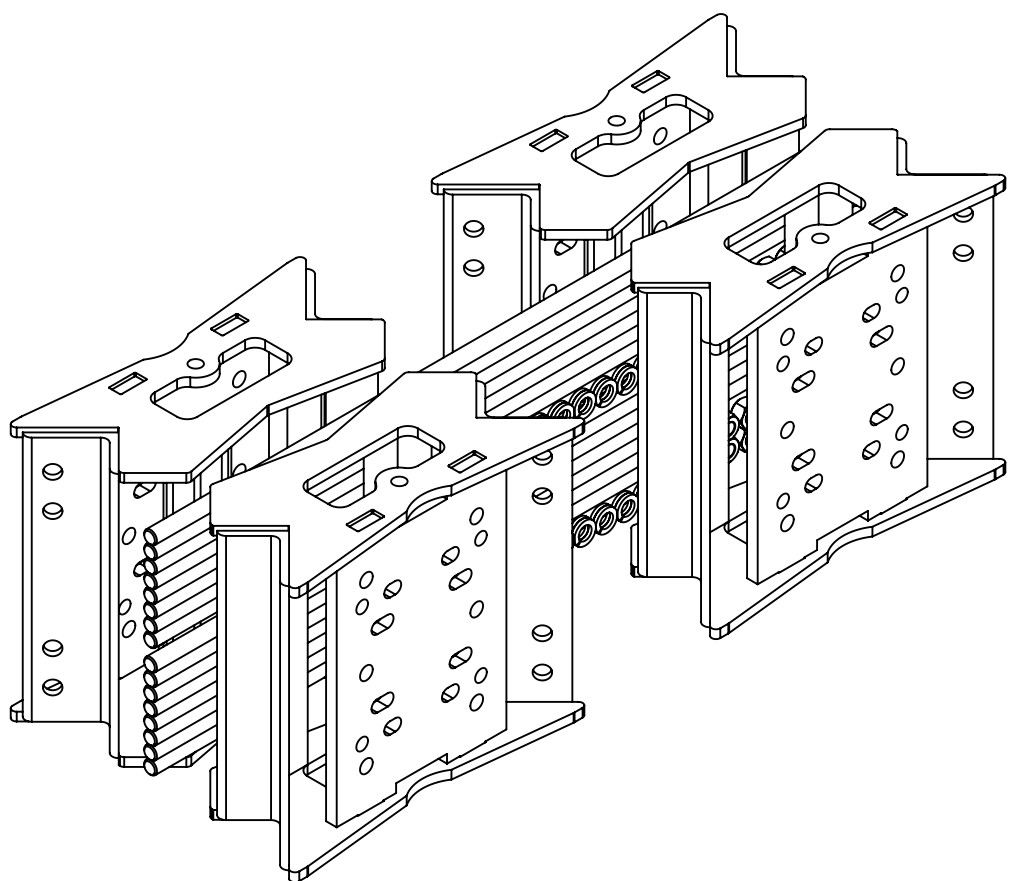

MC-RMHD-1545-4

(INCLUDING 1X RMHD1545-4-1000, 16X MT38440, 32X GWL-06 AND 32X GN-06)

4X

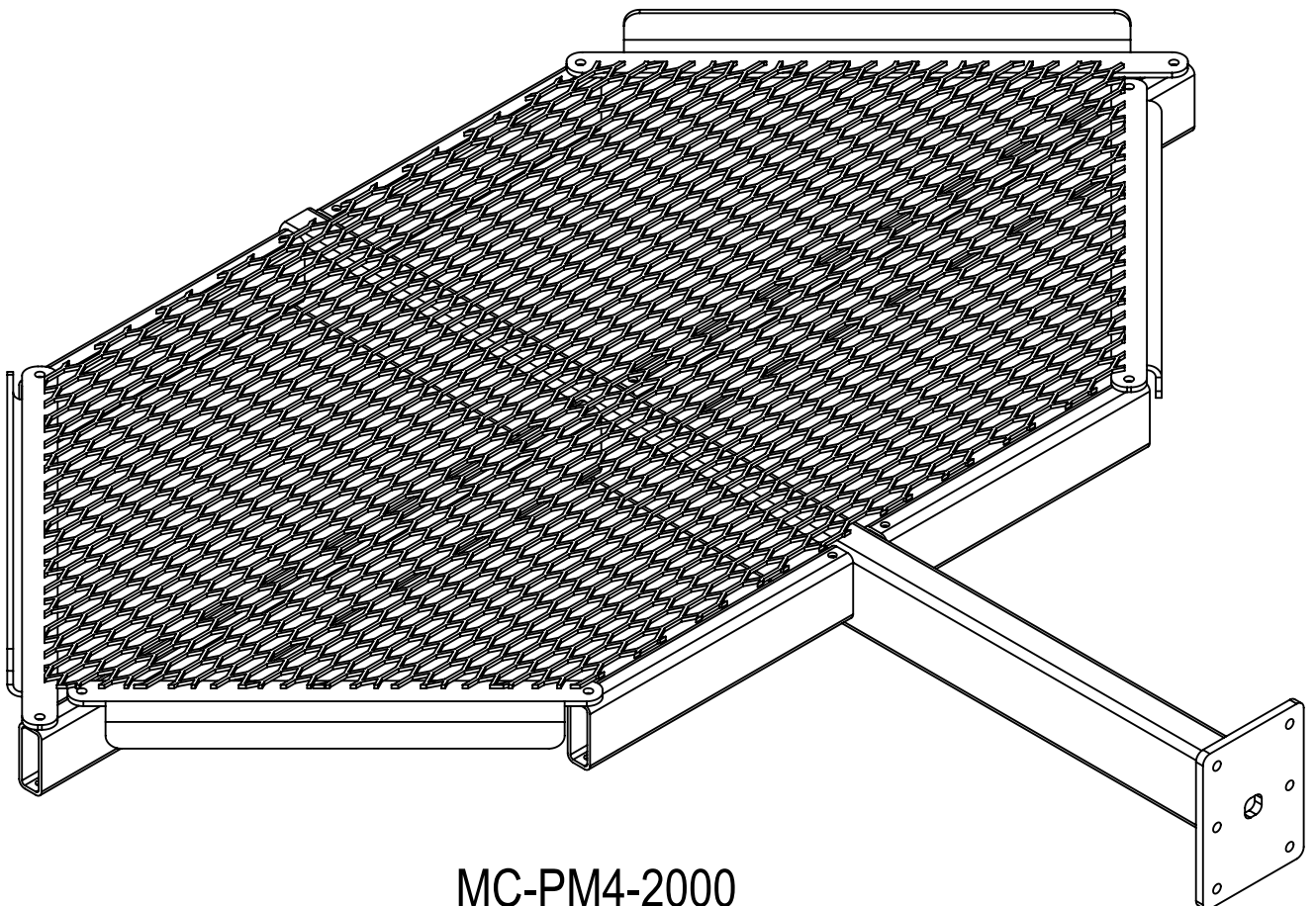

MC-PM4-2000

16X

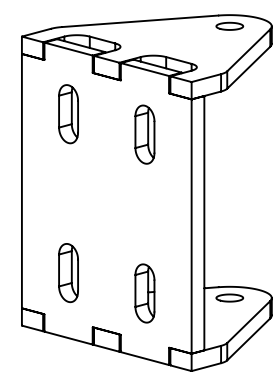

MCPM-2005-00

16X

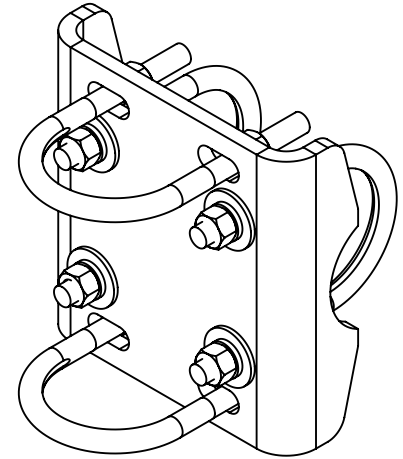

MT-219N-H

32X

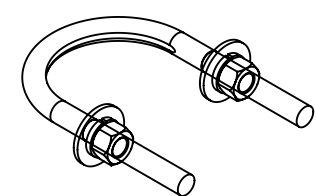

GUB-4352

32X

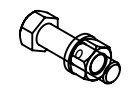

GB-04205

24X

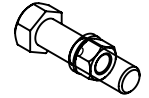

GB-0524A

4X

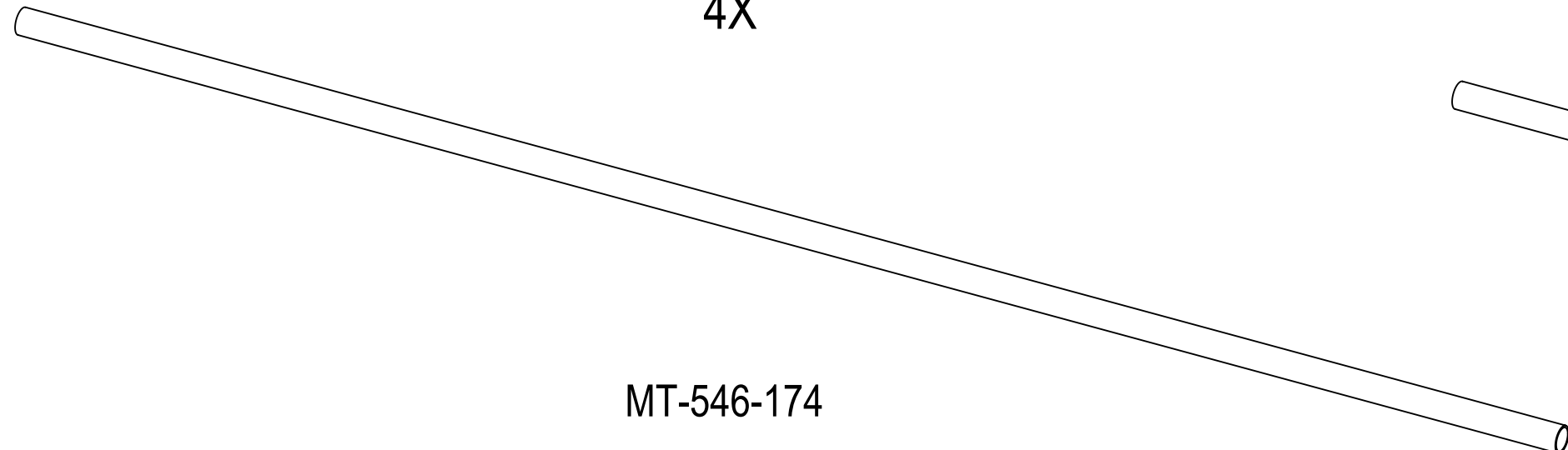

MT-546-174

16X

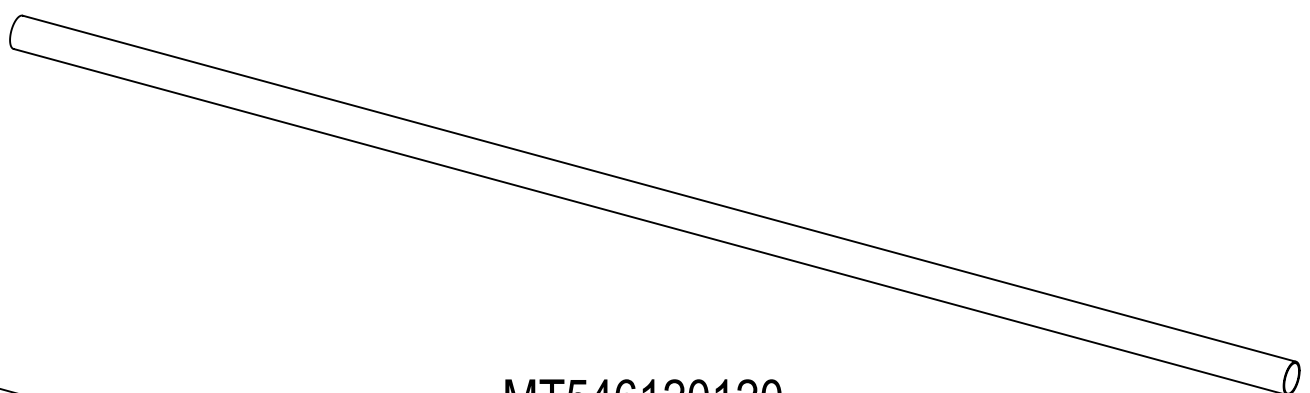

MT546120120

COMMSCOPE, INC. OF NORTH CAROLINA

TITLE
ATLAS4, 14' FP,(16)2.88" X120"AP

SIZE C	SCALE 1:8	DOCUMENT NO. MC-PM14M4-16-120
------------------	---------------------	---

DRAWING			SHEET 3 OF 7
VERSION 01	STATUS RE	REVISION B	

© 2022 CommScope, Inc. Confidential

4

3

2

1

STEP 1: ATTACH RING MOUNT SECTORS(RMHD1545-4-1000) TO MONOPOLE USING THREAD RODS (MT38440) AND NUT KITS (GWL-06 & GN-06)

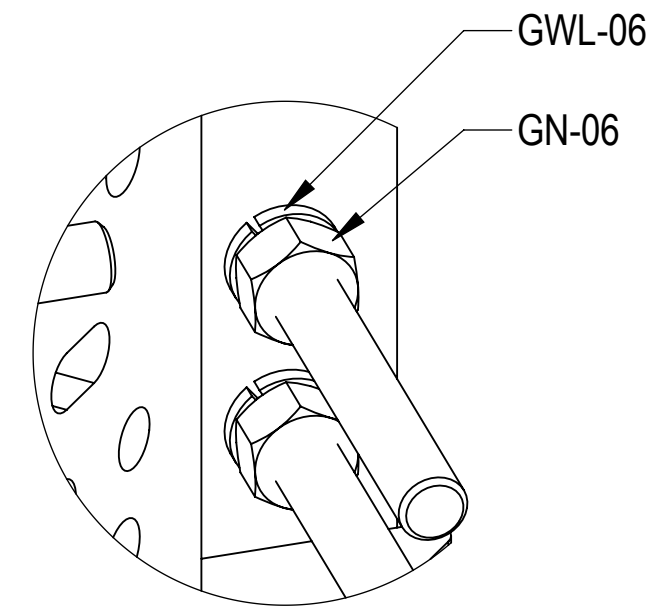
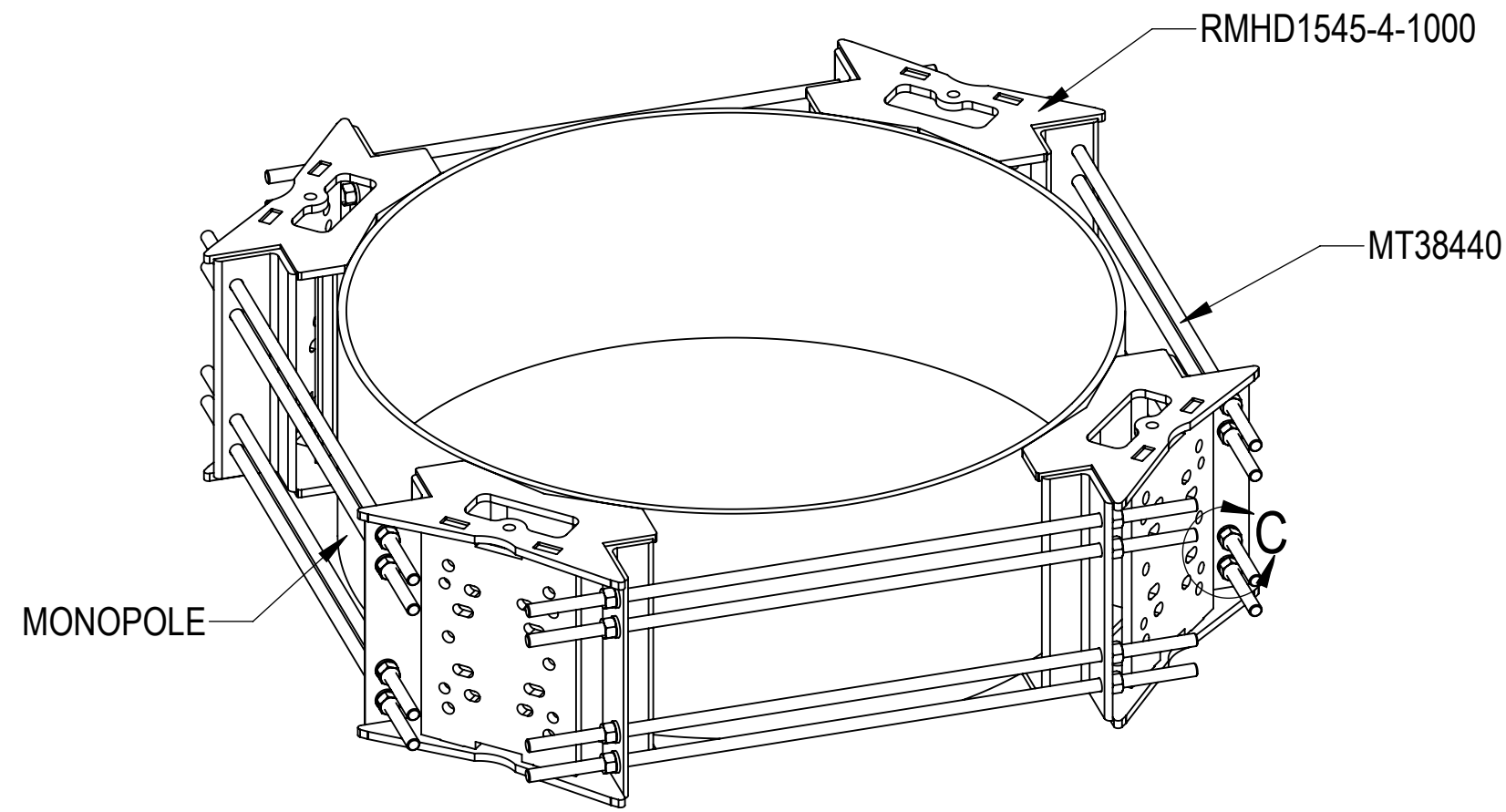

DETAIL C
SCALE 1 : 2

STEP 2: ATTACH PIPE MOUNTING BRACKETS (MCPM-2005-00) TO T-ARMS (MC-PM4-2000) USING BOLT KITS (GB-04205)

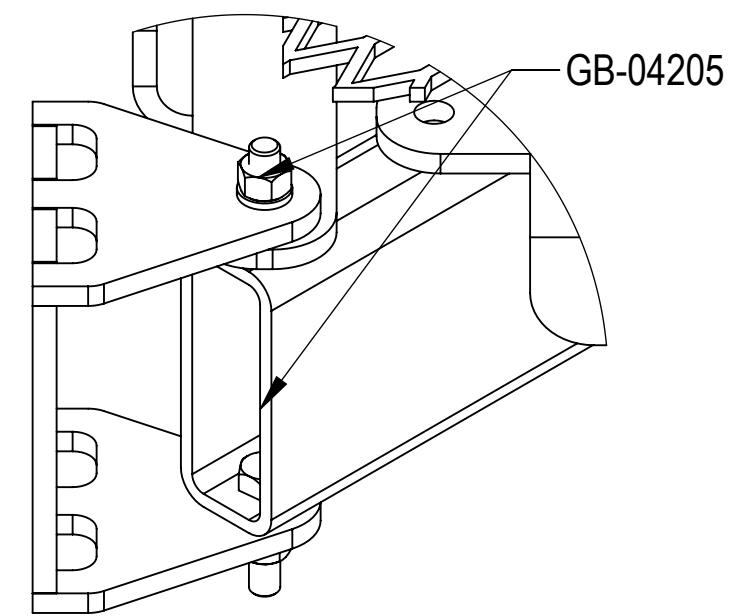
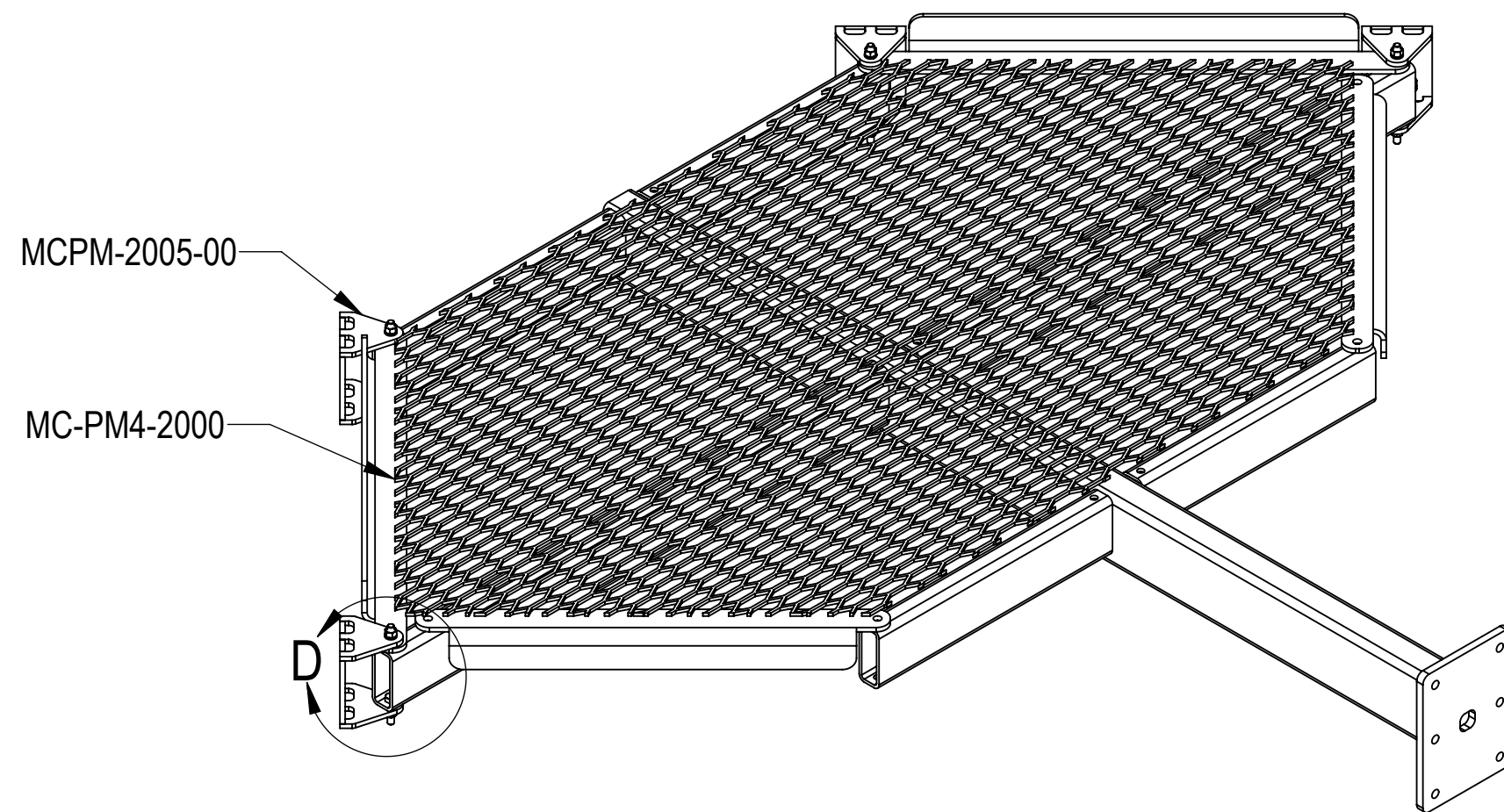

DETAIL D
SCALE 1 : 3

COMMSCOPE, INC. OF NORTH CAROLINA				
TITLE ATLAS4, 14' FP,(16)2.88" X120"AP				
SIZE C	SCALE 1:48	DOCUMENT NO. MC-PM14M4-16-120		
		DRAWING		SHEET
		VERSION	STATUS	REVISION
		01	RE	B
				4 OF 7

STEP 3: ATTACH T-ARMS (MC-PM4-2000) TO RING MOUNT (MC-RMHD-1545-4) USING BOLT KITS (GB-0524A)

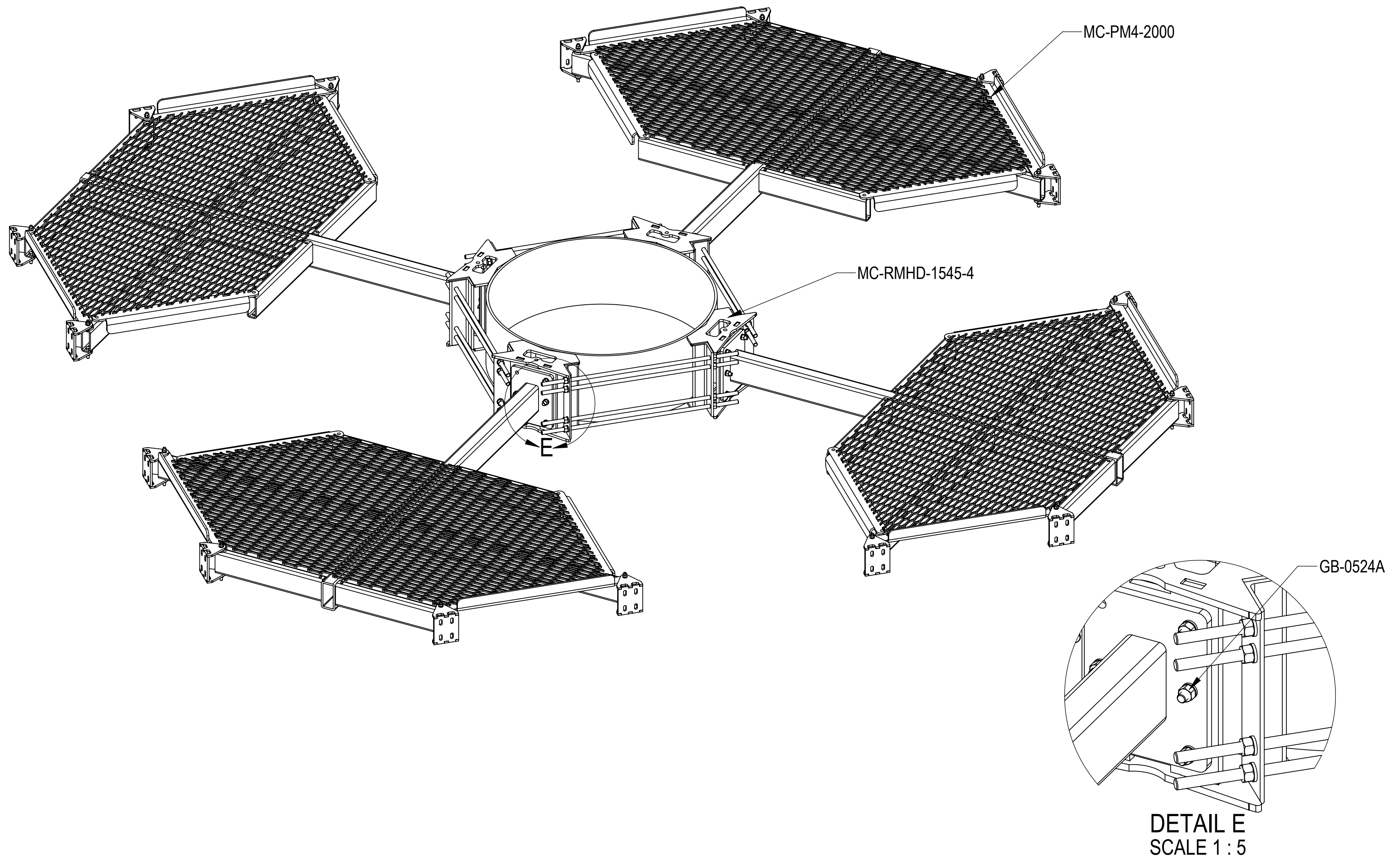

DETAIL E
SCALE 1 : 5

COMMSCOPE, INC. OF NORTH CAROLINA				
TITLE ATLAS4, 14' FP,(16)2.88" X120"AP				
SIZE C	SCALE 1:48	DOCUMENT NO. MC-PM14M4-16-120		
		DRAWING		SHEET
		VERSION	STATUS	REVISION
		01	RE	B
				SHEET 5 OF 7

STEP 4: ATTACH FACE PIPES (MT-546-174) TO T-ARMS (MC-PM4-2000) USING U-BOLT KITS (GUB-4352)

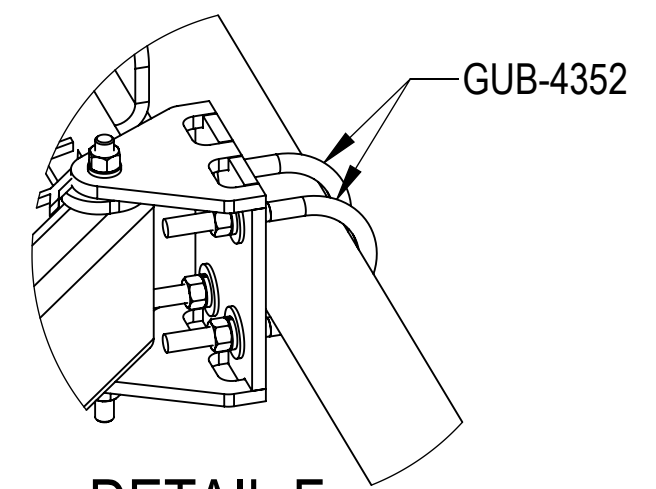
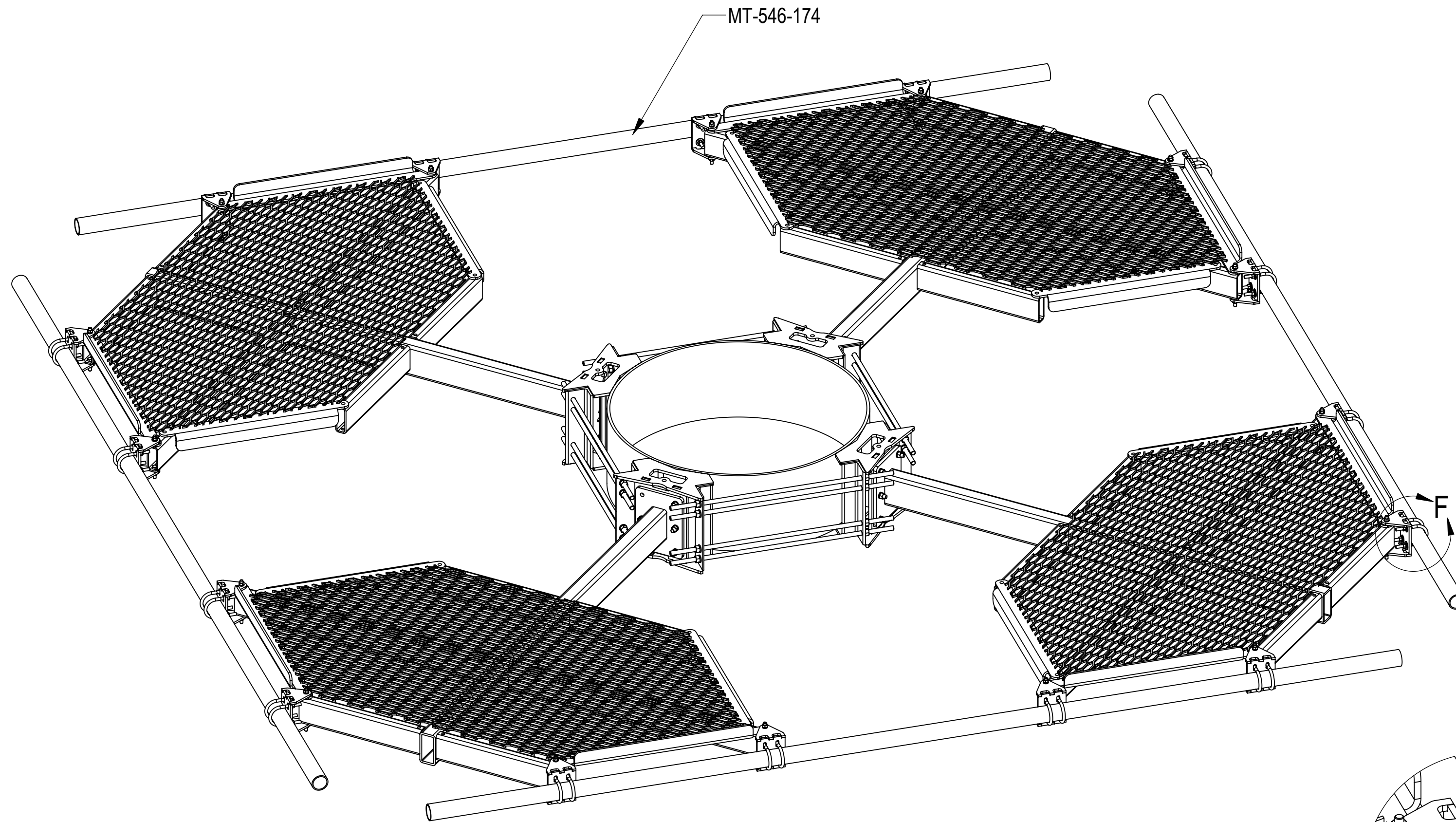

DETAIL F
SCALE 1 : 5

COMMSCOPE, INC. OF NORTH CAROLINA					
TITLE ATLAS4, 14' FP,(16)2.88" X120"AP					
SIZE C	SCALE 1:48	DOCUMENT NO. MC-PM14M4-16-120			
		DRAWING			SHEET 6 OF 7
		VERSION 01	STATUS RE	REVISION B	

STEP 5: ATTACH ANT PIPES (MT546120120) TO FACE PIPES (MT-546-174) USING SADDLE PIPE MOUNTING PLATES (MT-219N-H)

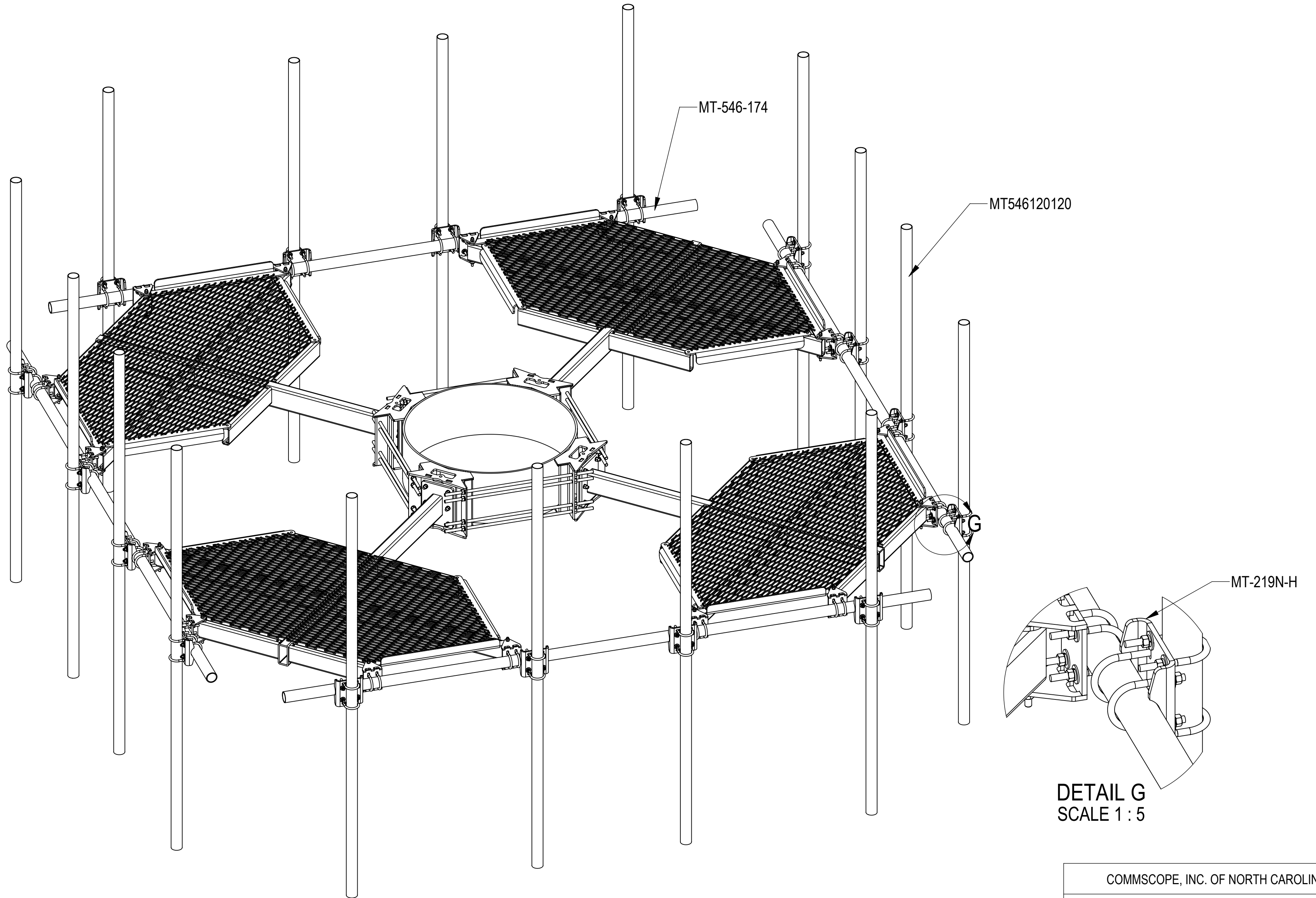

DETAIL G
SCALE 1 : 5

COMMSCOPE, INC. OF NORTH CAROLINA					
TITLE ATLAS4, 14' FP,(16)2.88" X120"AP					
SIZE C	SCALE 1:48	DOCUMENT NO. MC-PM14M4-16-120			
		DRAWING			SHEET
		VERSION	STATUS	REVISION	7 OF 7
		01	RE	B	