

NOTES:

REVISIONS			
REV.	DESCRIPTION	DATE	APPROVED
A	ECR 800007715: REL TO PRODUCTION.	23JUL15 SWD	SHEN.MIN/ZHANG.XU
B	ECR 8000032959: UPDATE DRAWING ERROR.	12DEC18 QF	S.LIU/JIHE

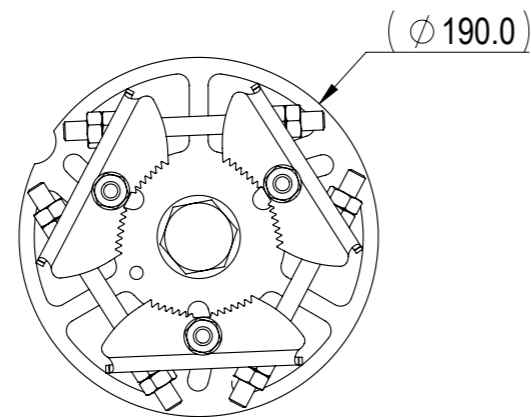
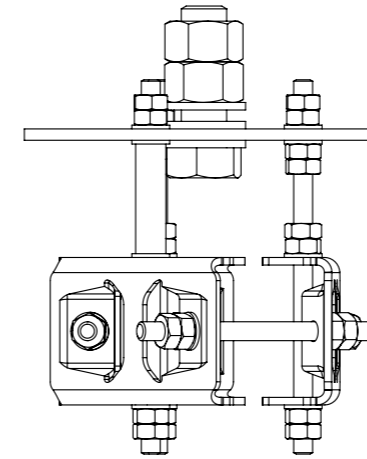
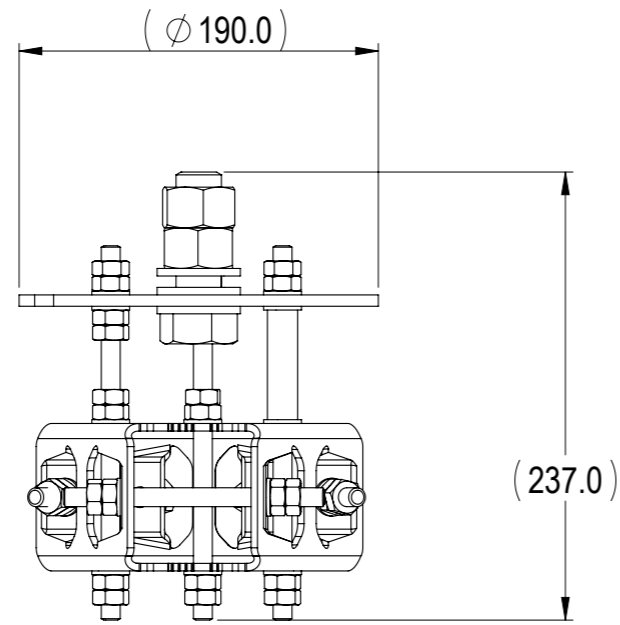

**MC-MNT-3XV-TS1
TOP MOUNT**

COMMScope, INC. OF NORTH CAROLINA											
TOLERANCES						SAP MATERIAL MASTER					
0 PLACE X ±		2 PLACE .XX ±									
1 PLACE .X ±		ANGLES ±									
FINISH N/A						MATERIAL N/A					
PRODUCT DRAWING											
UNLESS OTHERWISE SPECIFIED DIMENSIONS ARE IN MILLIMETERS INTERPRET PER ISO STANDARDS HANDBOOK, TECHNICAL DRAWINGS, VOLUMES 1 & 2, THIRD EDITION (2002)		NAME	DATE	TITLE							
CE	SWD	23JUL15	PRODUCT DRAWING								
RW	QW1004	12/12/2018									
RV	CHALIU	12/12/2018									
AD	JIHE	12/18/2018									
RE	ZHHCHEN	12/19/2018									
ECN 8000032959-O		SCALE	DOCUMENT NO.								
		1:5	MC-MNT-3XV-TS1-L								
SIZE		WORK AREA	MODEL			DRAWING			SHEET		
A3		23	VERSION	STATUS	REVISION	VERSION	STATUS	REVISION	1 OF 3		
			00	RE	A	01	RE	B			

DENSITY	g/mm ³
MASS	grams
VOLUME	mm ³
SURFACE AREA	mm ²
HEIGHT	
LENGTH	
WIDTH	

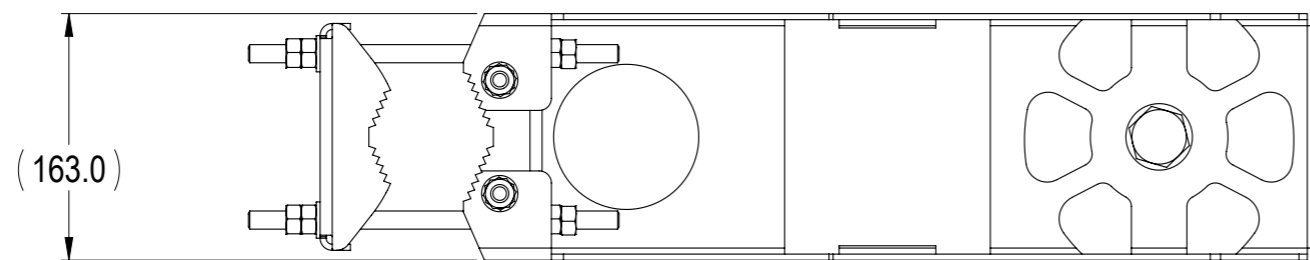
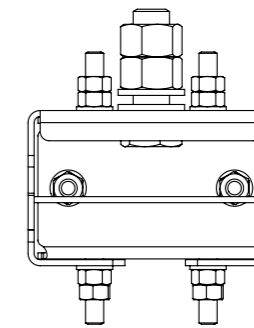
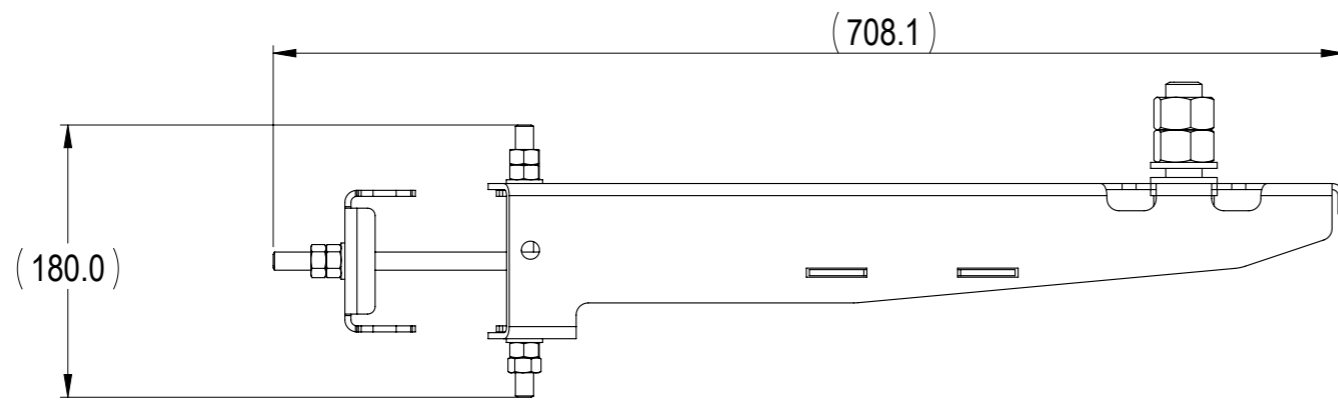

**MC-MNT-3XV-TS1
SIDE MOUNT OPTION 1**

COMMSCOPE, INC. OF NORTH CAROLINA

TITLE

PRODUCT DRAWING

SIZE

A3

SCALE

1:5

DOCUMENT NO.

MC-MNT-3XV-TS1-L



DRAWING

VERSION

STATUS

REVISION

SHEET

01

RE

B

2 OF 3

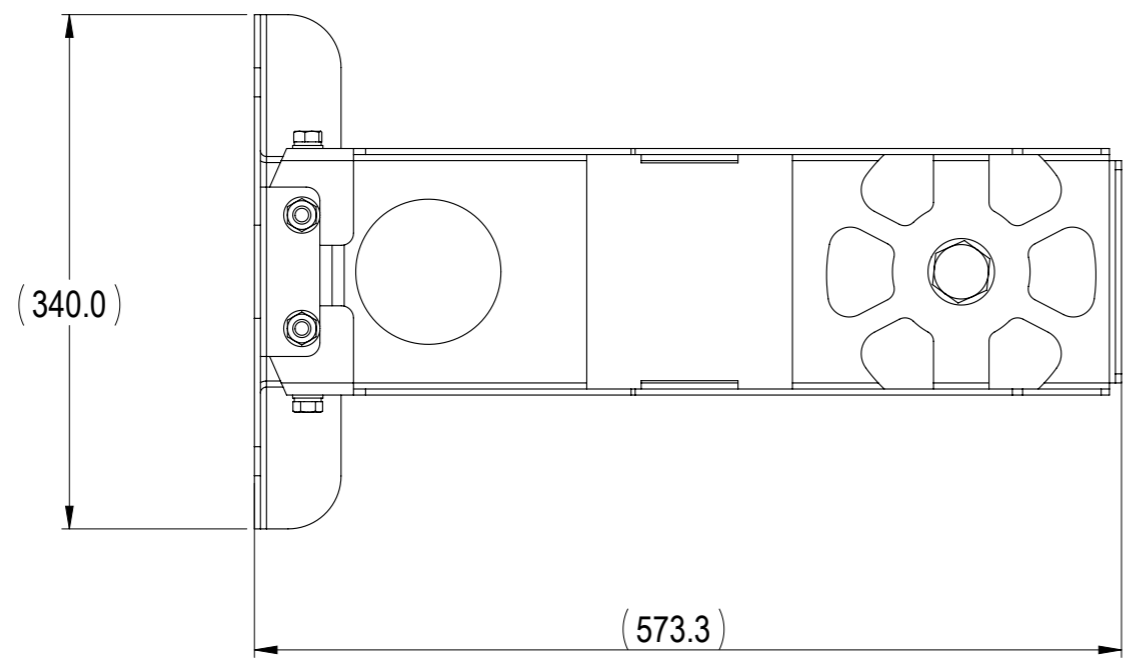
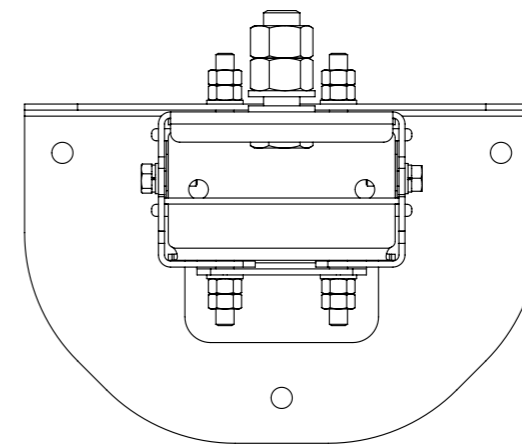
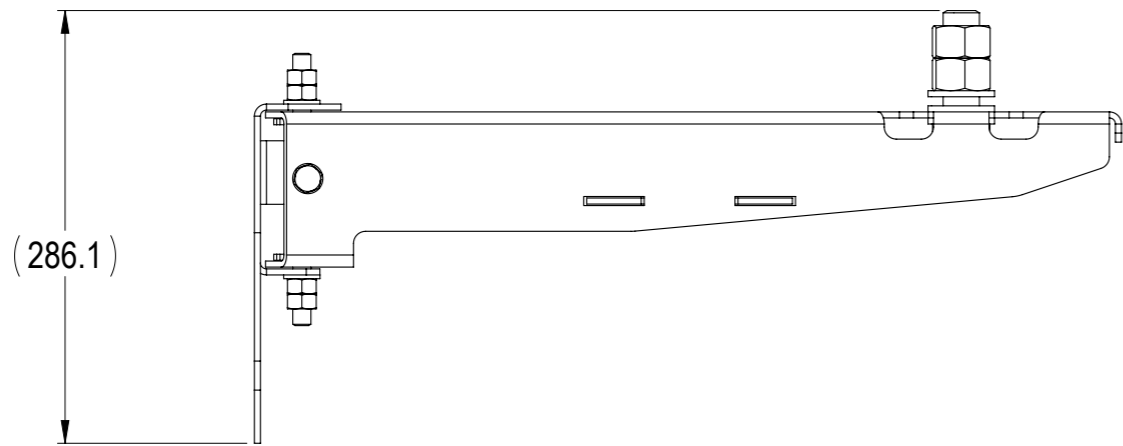

**MC-MNT-3XV-TS1
SIDE MOUNT OPTION 2**

COMMSCOPE, INC. OF NORTH CAROLINA					
TITLE PRODUCT DRAWING					
SIZE A3	SCALE 1:5	DOCUMENT NO. MC-MNT-3XV-TS1-L			
		DRAWING			SHEET 3 OF 3
		VERSION 01	STATUS RE	REVISION B	