

4

3

2

1

- 1.0 GENERAL NOTES
  - 1.1 ALL METRIC DIMENSIONS ARE IN BRACKETS [X. X]
  - 1.2 FOR PATENT INFO: <https://www.cs-pat.com>
- 2.0 DESIGN NOTES
- 3.0 MANUFACTURING/SPECIAL REQUIREMENTS
  - 3.1 AT ASSEMBLY, TIGHTEN ALL MOUNTING BOLTS SNUG TIGHT, DEFINED AS THE CONDITION OBTAINED WITH THE FULL EFFORT OF AN ASSEMBLER USING AN ORDINARY SPUD WRENCH TO BRING THE CONNECTING SURFACES INTO FIRM CONTACT
- 4.0 TEST
- 5.0 PACKAGING
  - 5.1 PACKAGING SHALL MEET COMMSCOPE REQUIREMENTS PER DOCUMENT IS-PL-3005
  - 5.2 PRINTED DOCUMENT TO BE PLACED INSIDE POLYBAG AND THEN IN SHIPPING CONTAINER

REVISIONS			
REV.	DESCRIPTION	DATE	APPROVED
A	INITIAL RELEASE	AG1119 15DEC23	RW1043 40185290CMO

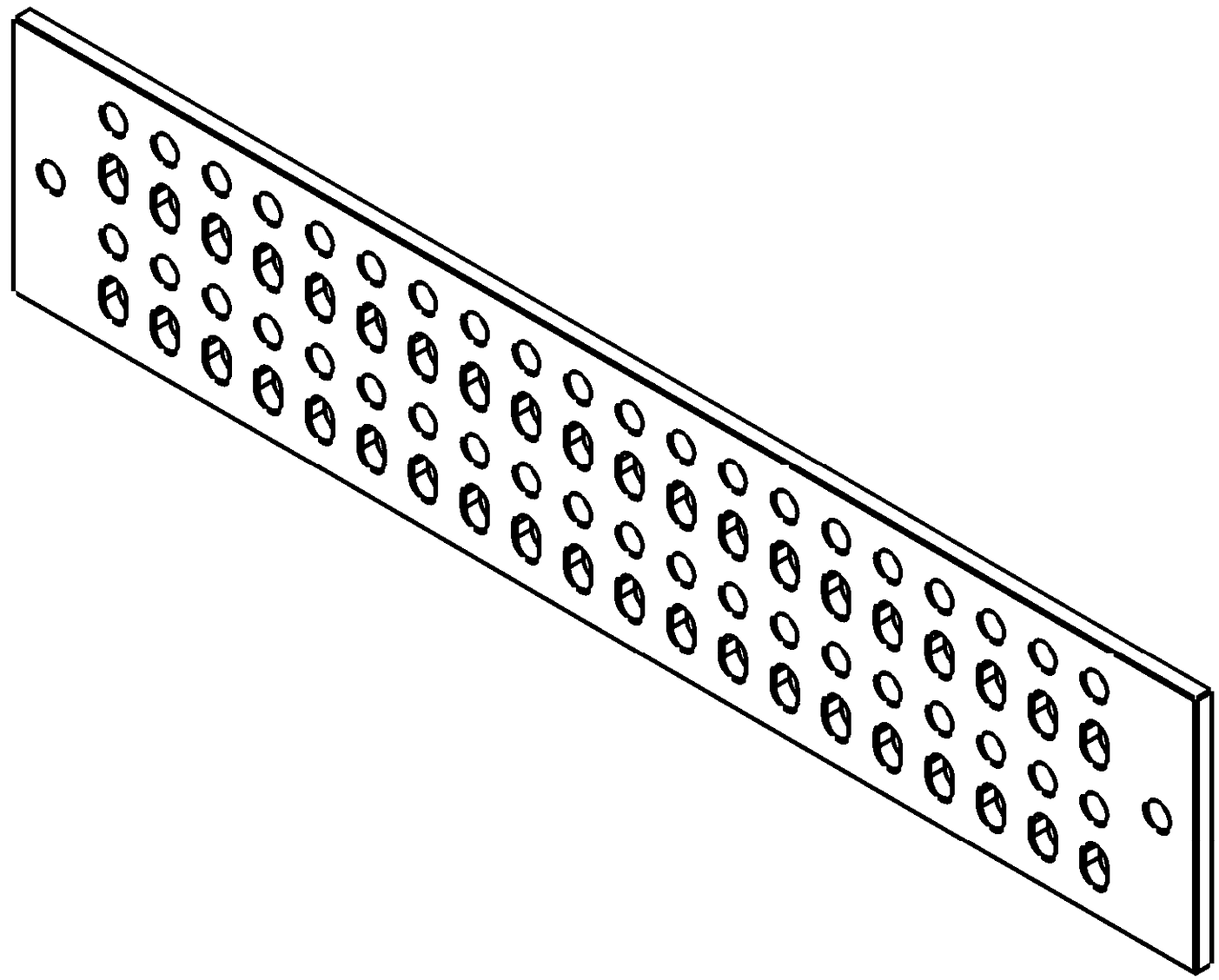
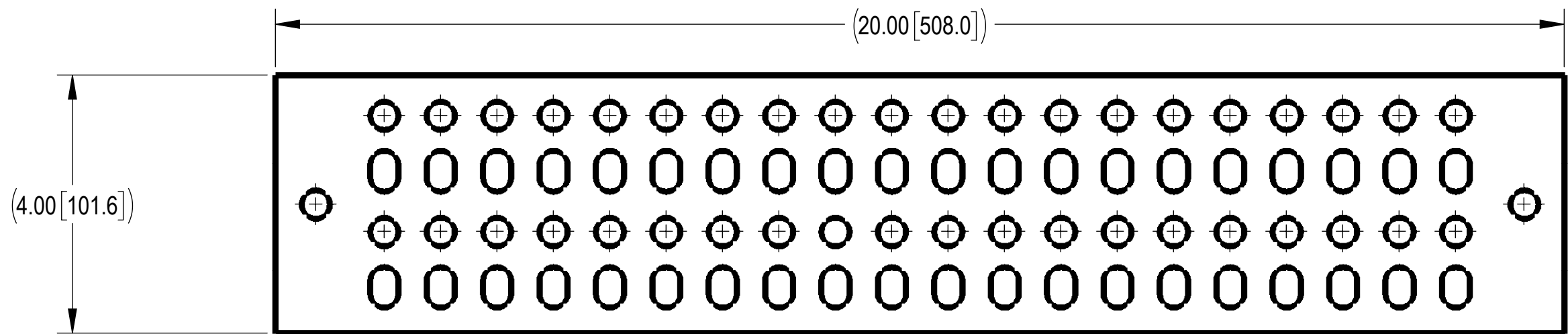

**COMMSCOPE, INC. OF NORTH CAROLINA**

TOLERANCES		SAP MATERIAL MASTER							
1 PLACE .X[X] ± 0.2[6.3]	3 PLACE .XXX[X] ± 0.060[1.5]	<b>UGB-0420-G</b>							
2 PLACE .XX[X] ± 0.12[3.0]	ANGLES ± 2°								
FINISH STEEL, GALVANIZED		MATERIAL SEE BOM							
<small>UNLESS OTHERWISE SPECIFIED DIMENSIONS ARE IN INCHES INTERPRET PER ANSI Y 14.5M-1994</small>		NAME	DATE	<b>GALV GROUND BAR: 4X20" NO/HRDWR</b>					
		CE LL1090	30OCT23						
		RW AG1119	12/14/2023						
		AD RW1043	12/14/2023						
		RE AG1119	12/14/2023						
ECN 40185280CMO		SCALE <b>1:2</b>	DOCUMENT NO. <b>UGB-0420-G</b>						
SIZE	Auth Group	INSL	MODEL		DRAWING			SHEET	
C			VERSION	STATUS	REVISION	VERSION	STATUS	REVISION	1 OF 1
			01	RE	E	00	RE	A	

**BILL OF MATERIALS**

COMPONENT PART NUMBERS PROVIDED FOR ASSEMBLY PURPOSES;  
INDIVIDUAL COMPONENTS MAY BE SHIPPED AS PARTS WITHIN AN INCLUDED KIT.

BOM Table				
ITEM NO.	PART NUMBER	DESCRIPTION	QTY.	NOTES
1	MTC977302	GROUND BUS BAR, 4"X20", GALV	1	5.2