

4

3

2

1

- 1.0 GENERAL NOTES
- 1.1 ALL METRIC DIMENSIONS ARE IN BRACKETS [X.X]
- 1.2 FOR PATENT INFO: <https://www.cs-pat.com>

- 2.0 DESIGN NOTES
- 2.1 ANY HAZARDS OR OBSTRUCTIONS TO THE CLIMBING FACILITY AND SAFETY CLIMB MUST BE IDENTIFIED PRIOR TO INSTALLING THE APPURTENANCE. ADDITIONAL PRODUCTS MAY BE REQUIRED TO MAINTAIN THE INTEGRITY OF THE SAFETY CLIMB. DURING INSTALLATION, TEMPORARY AND/OR PERMANENT PRECAUTIONARY MEASURES SHOULD BE TAKEN TO PRESERVE THE CLIMBING FACILITY AND/OR SAFETY CLIMB.
- 2.2 UP TO 5.0° TAPER AVAILABLE ON MODELS THAT SUPPORT ADJUSTMENT

- 3.0 MANUFACTURING/SPECIAL REQUIREMENTS
- 3.1 TIGHTEN ALL BOLTS SECURING FLAT PLATES BY THE TURN-OF-NUT METHOD. TIGHTEN ALL U-BOLTS USING TURN-OF-NUT METHOD WITH ATTENTION TO LEAVE EQUAL DISTANCE AND EQUAL FORCE ON EACH LEG OF THE U-BOLT.

- 4.0 TEST
- 5.0 PACKAGING
- 5.1 PACKAGING SHALL MEET COMMSCOPE REQUIREMENTS PER DOCUMENT IS-PL-3005.
- 5.2 PRINTED DOCUMENT TO BE PLACED INSIDE POLYBAG AND THEN IN SHIPPING CONTAINER.
- 5.3 EXTRA HARDWARE MAYBE SUPPLIED, BAGGED AND SHIPPED.

REVISIONS			
REV.	DESCRIPTION	DATE	APPROVED
A	INITIAL RELEASE	YMENG 09OCT23	YW1047 40179448CMO

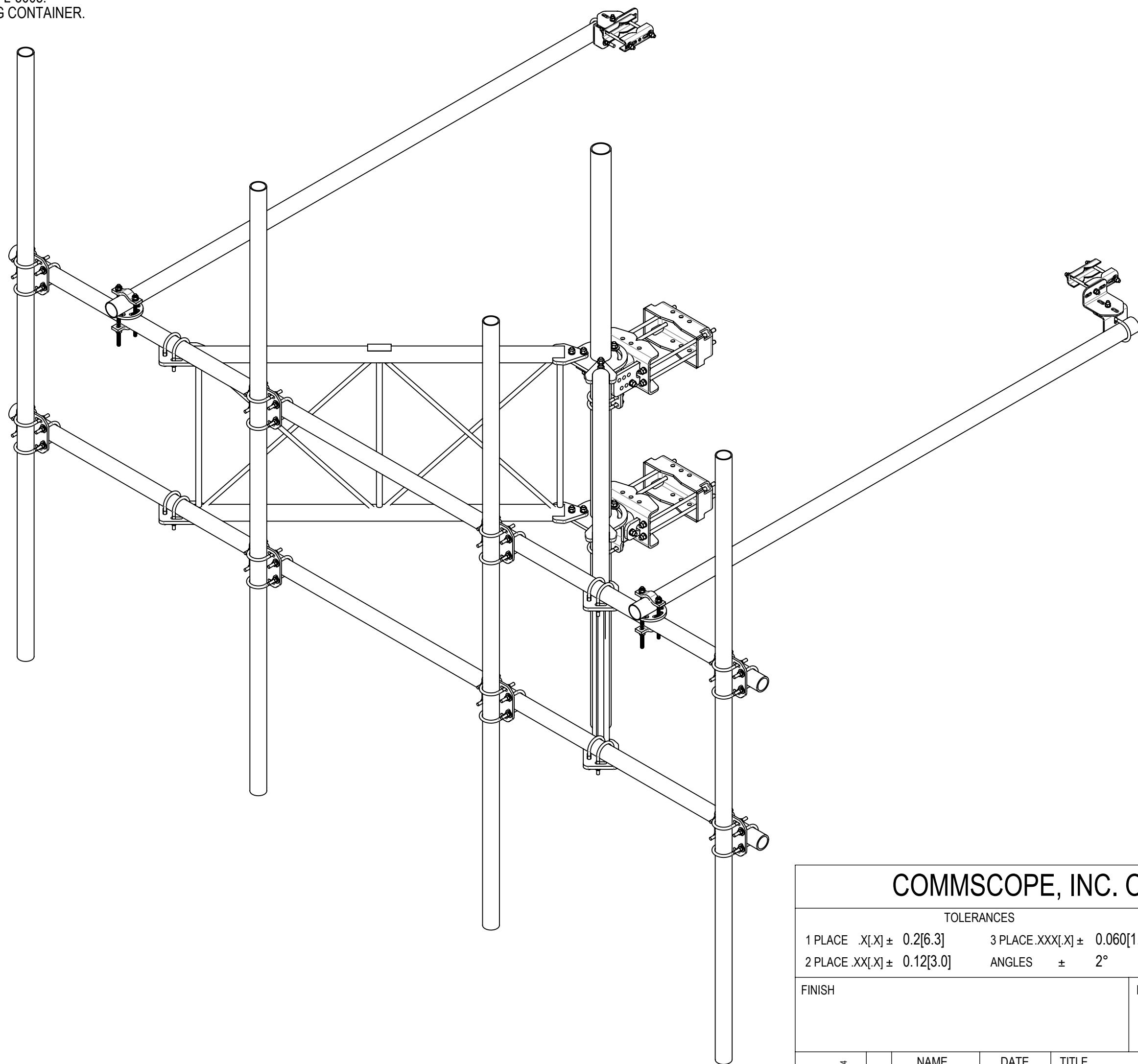

<b>COMMSCOPE, INC. OF NORTH CAROLINA</b>			
TOLERANCES		SAP MATERIAL MASTER	
1 PLACE .X[X] ± 0.2[6.3]	3 PLACE .XXX[X] ± 0.060[1.5]	<b>SFG23RHDXL15-4-126</b>	
2 PLACE .XX[X] ± 0.12[3.0]	ANGLES ± 2°		
FINISH		MATERIAL	
UNLESS OTHERWISE SPECIFIED DIMENSIONS ARE IN INCHES INTERPRET PER ANSI Y 14.5M-1994	NAME	DATE	TITLE
	CE YMENG	09OCT23	<b>SF, 15',(4)2.88"X126"-PIPES-PIM-SPACED</b>
	RW YMENG	10/18/2023	
	AD YW1047	10/18/2023	
	RE YMENG	10/18/2023	
ECN 40179448CMO			
SCALE	DOCUMENT NO.		
<b>1:32</b>	<b>SFG23RHDXL15-4-126</b>		
SIZE	Auth Group	INSL	MODEL
<b>C</b>			
VERSION	STATUS	REVISION	DRAWING
00	RE	A	VERSION STATUS REVISION
			00 RE A
			SHEET
			1 OF 5

DENSITY		lbs/in <sup>3</sup>
MASS	1110.84	lbs
VOLUME	3917.43	in <sup>3</sup>
SURFACE AREA	33664.99	in <sup>2</sup>
HEIGHT	126"	
LENGTH	180"	
WIDTH	120"	

© 2023 CommScope, Inc. Confidential

4

3

2

1

4

3

2

1

D

D

C

C

B

B

A

A

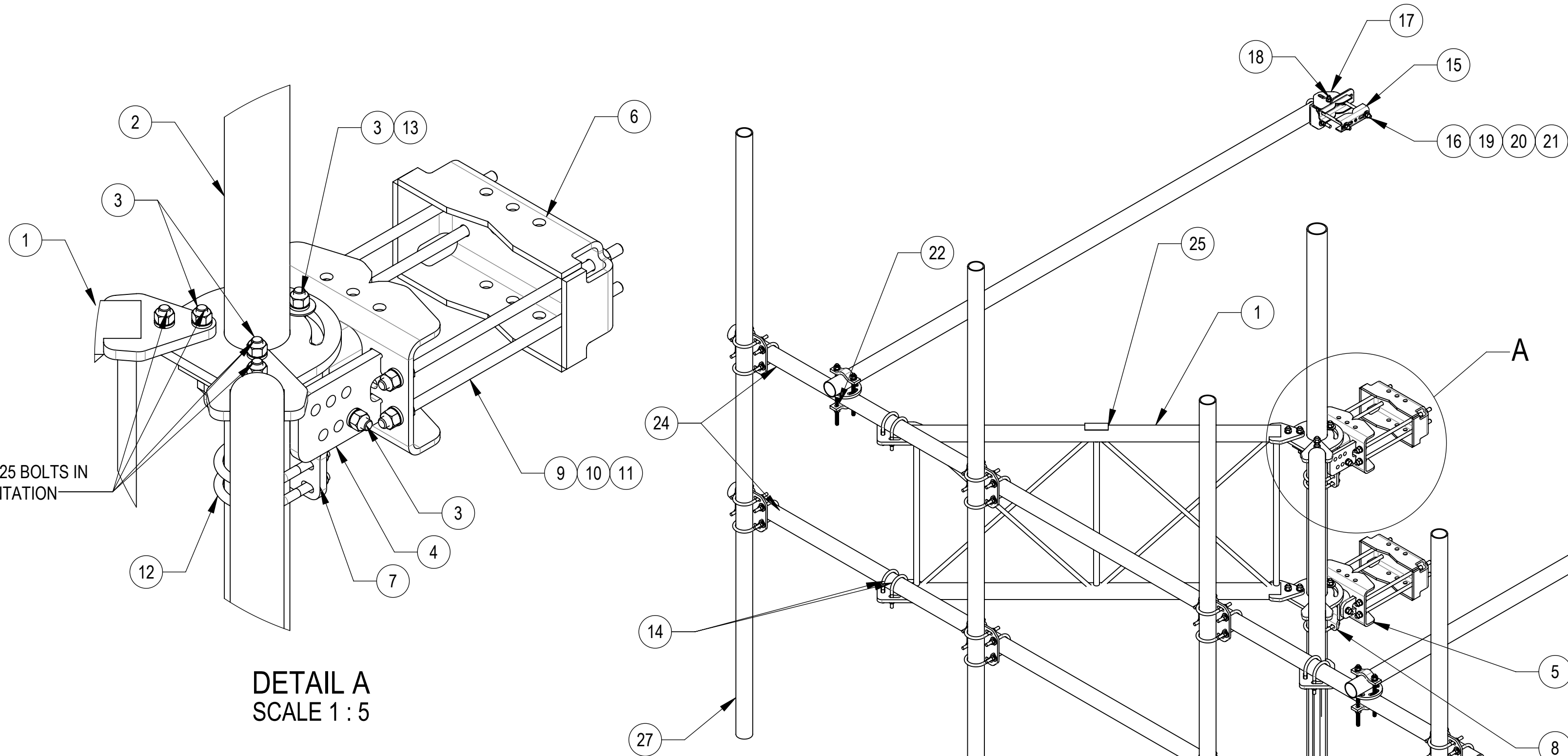

ALL GB-05225 BOLTS IN THIS ORIENTATION

**DETAIL A**  
SCALE 1 : 5

COMPONENT PART NUMBERS PROVIDED FOR ASSEMBLY PURPOSES;  
INDIVIDUAL COMPONENTS MAY BE SHIPPED AS PARTS WITHIN AN INCLUDED KIT.

ITEM	PART NO.	DESCRIPTION	QTY.	WEIGHT	NOTE NO.
1	SFG23180-00	ARM, STANDOFF, SFG23	2	120.07 LBS	
2	SFG2204	WELDMENT, BACK VERTICAL ARM MOUNT	1	97.29 LBS	
3	GB-05225	5/8" X 2-1/4" GALV BOLT KIT	14	0.28 LBS	
4	SFG2380	WELDMENT, HD, TOP TAPER BRACKET	1	22.78 LBS	
5	SFG2381	WELDMENT, HD, LOWER TOWER LEG BRACKET	1	17.42 LBS	
6	SFG2289	G2 RRU BACK CLAMP, HD	2	18.65 LBS	
7	SFG2386	WELDMENT, SFG2 AZIMUTH BRACKET	1	10.69 LBS	
8	SFG2397-00	WELDMENT, G23 AZIMUTH BRACKET	1	8.56 LBS	
9	MT-382-18	5/8" X 18" THREADED ROD	8	1.43 LBS	
10	GWL-05	5/8" GALV LOCK WASHER	16	0.03 LBS	
11	GN-05	5/8" GALV HEX NUT	24	0.08 LBS	
12	GUB-4355	1/2" X 3-5/8" X 5" GALV U-BOLT	3	0.71 LBS	
13	GWF-05	5/8" GALV FLAT WASHER, 1.7OD	2	0.06 LBS	
14	GUB-4352	1/2" X 3" X 5-1/4" GALV U-BOLT	10	0.71 LBS	
15	SAB01	FORMED CLAMP	4	1.35 LBS	
16	MT-379-8	1/2" X 8" GALV THREADED ROD	4	0.45 LBS	
17	XAU01	ANGLE, CROSSOVER, 1.9-3.5" X 1.9-3.5" OD	4	2.98 LBS	
18	GB-04145	1/2" X 1-1/2" GALV BOLT KIT	2	0.13 LBS	
19	GWF-04	1/2" GALV FLAT WASHER	8	0.04 LBS	
20	GWL-04	1/2" GALV LOCK WASHER	10	0.01 LBS	
21	GN-04	1/2" GALV HEX NUT	10	0.04 LBS	
22	XP-R	CROSSOVER PLATE, ROUND, UP TO 3.5" OD	2	6.20 LBS	
23	MT546120120	PIPE, 2.875"OD X 120"	2	35.44 LBS	
24	MT546180276	PIPE, 2.875"OD X 180"	2	115.33 LBS	
25	SFG23100	LABEL, SFG23RHDXL	1	0.04 LBS	
26	XP-2525	CROSSOVER PLATE KIT, 2-7/8 OD X 2-7/8 OD	8	8.37 LBS	
27	MT-546-126	PIPE, 2.875"OD X 126"	4	61.05 LBS	

**ALLOWABLE TIEBACK ANGLE**

+15 DEGREES VERTICAL  
±25 DEGREES HORIZONTAL

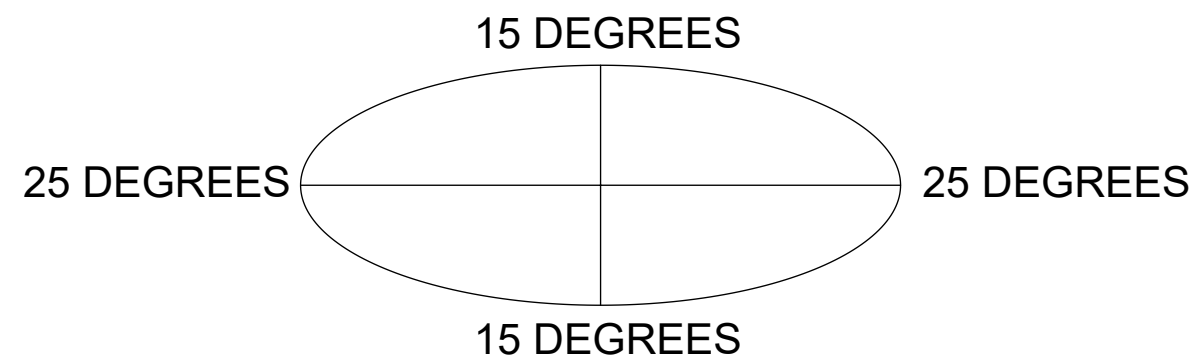

TOP  
↓  
BOTTOM

COMMSCOPE, INC. OF NORTH CAROLINA

TITLE  
SF, 15',(4)2.88"X126"-PIPES-PIM-SPACED

SIZE C SCALE 1:16 DOCUMENT NO. SFG23RHDXL15-4-126

DRAWING	VERSION	STATUS	REVISION	SHEET 2 OF 5
	00	RE	A	

© 2023 CommScope, Inc. Confidential

4

3

2

1

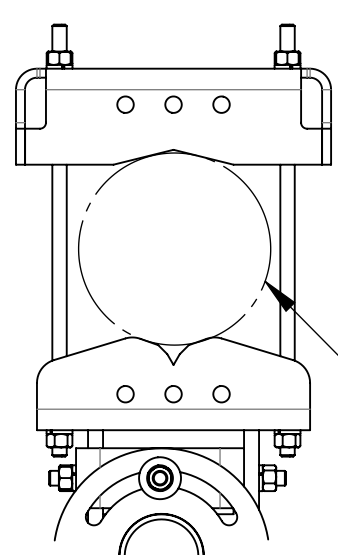
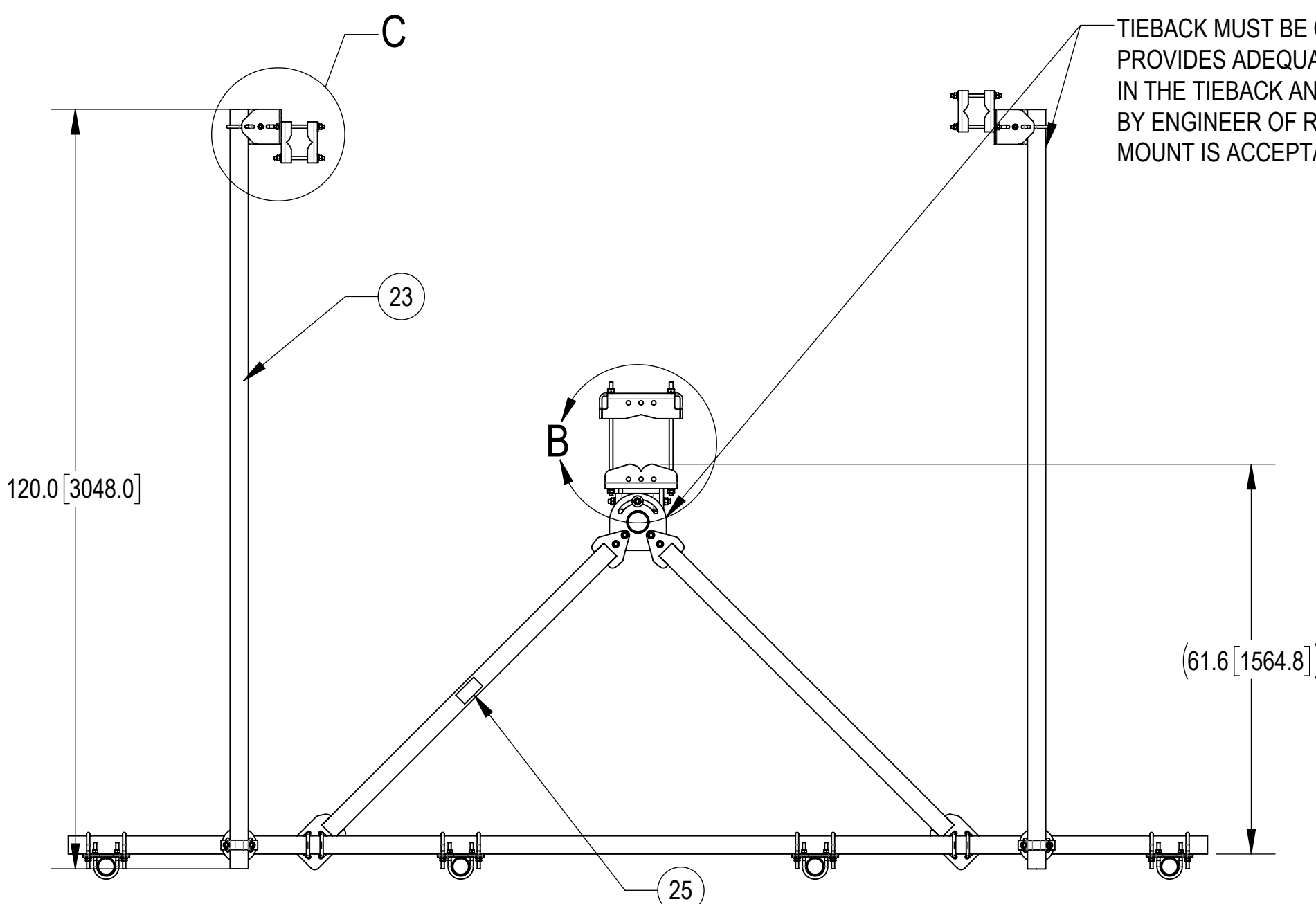

DETAIL B  
SCALE 1 : 8

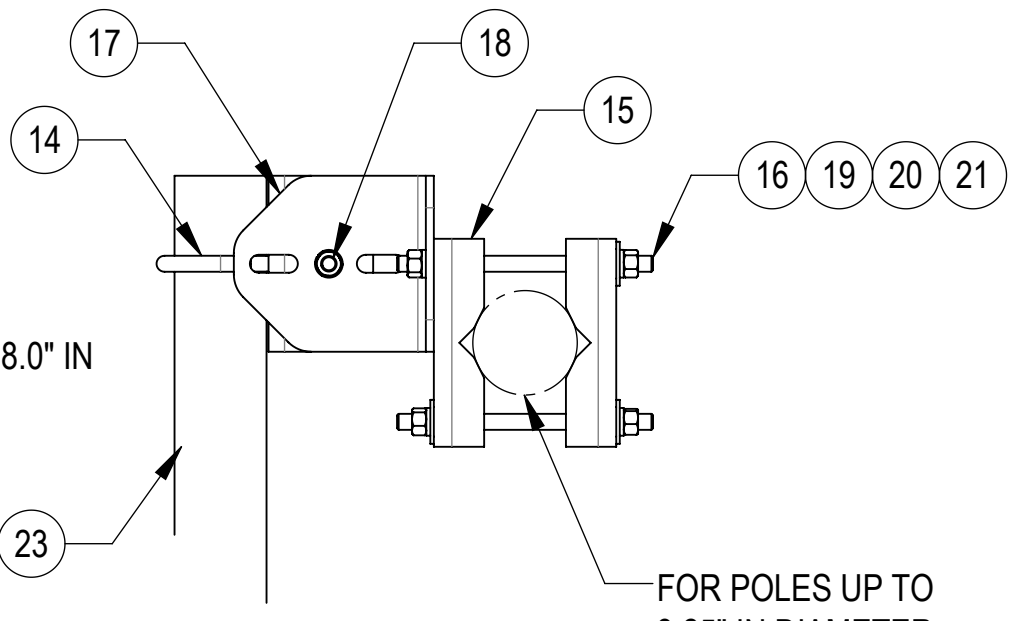

DETAIL C  
SCALE 1 : 6

**ALLOWABLE TIEBACK ANGLE**  
 ±15 DEGREES VERTICAL  
 ±25 DEGREES HORIZONTAL

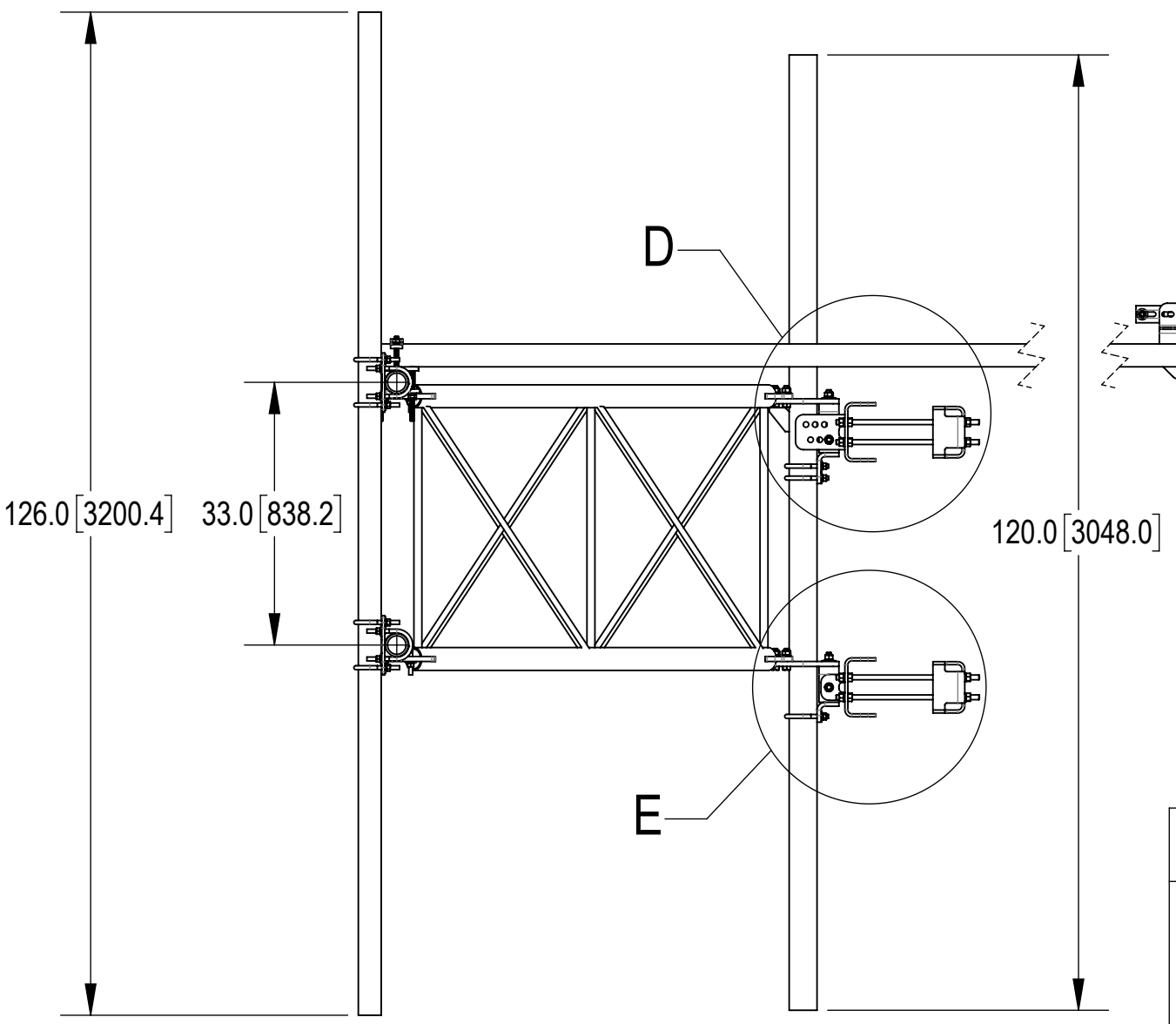
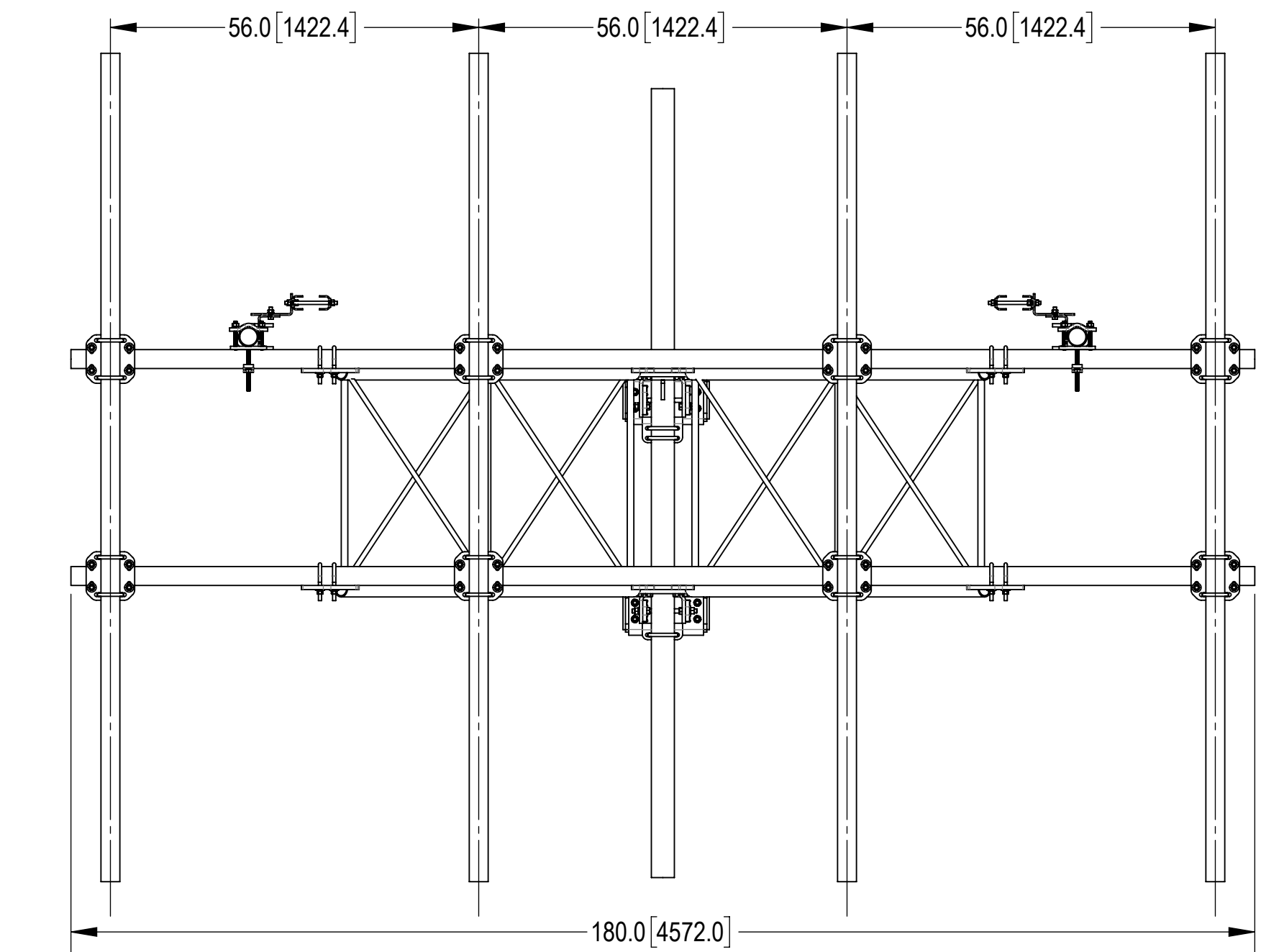
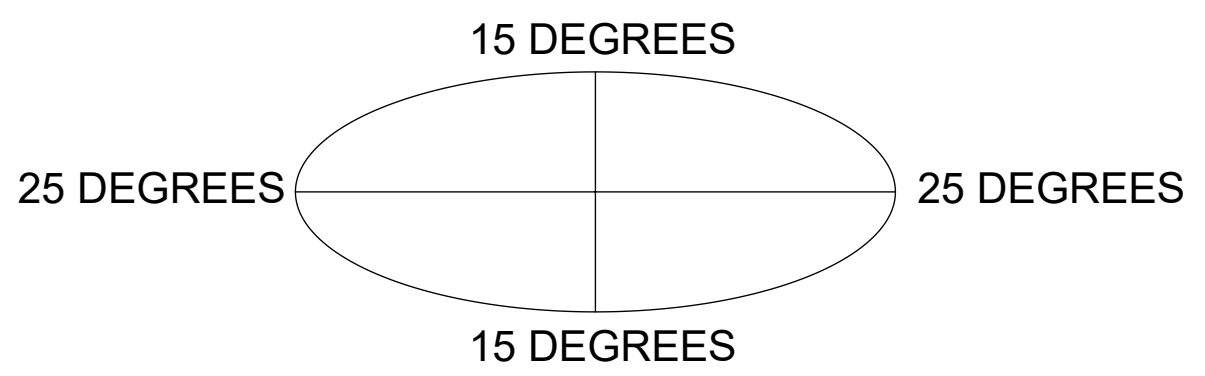

TOP  
 BOTTOM

COMMSCOPE, INC. OF NORTH CAROLINA				
TITLE SF, 15', (4) 2.88" X 126" - PIPES - PIM - SPACED				
SIZE C	SCALE 1:21	DOCUMENT NO. SFG23RHDXL15-4-126		
DRAWING		VERSION	STATUS	REVISION
SHEET		00	RE	A
				SHEET 3 OF 5

4

3

2

1

4

3

2

1

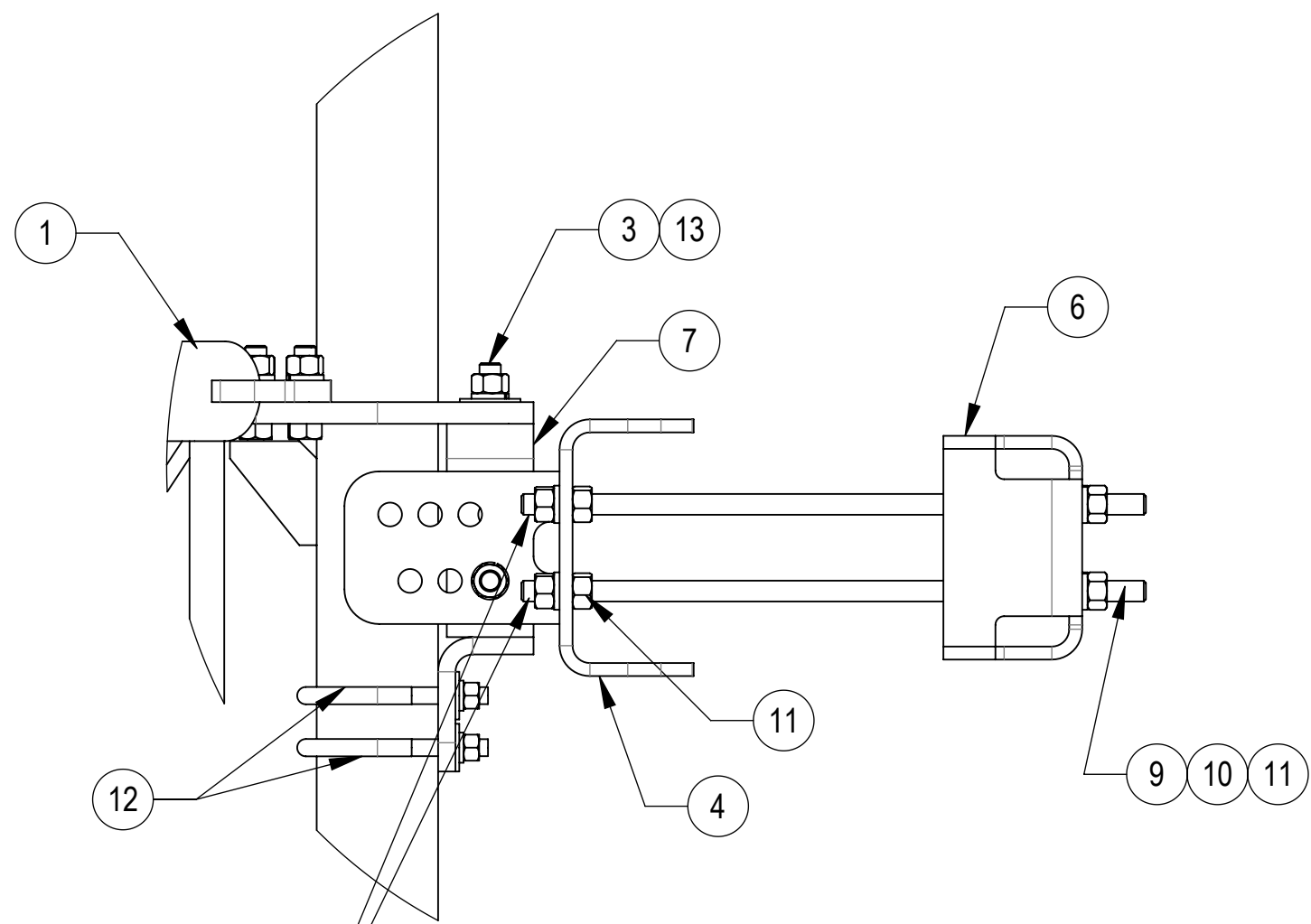

**DETAIL D**  
SCALE 1 : 5

THE THREADED ROD CAN ONLY EXPOSE 4 TO 7 THREADS ON ONE SIDE OF THE BRACKET, WHICH IS TO PREVENT INTERFERENCE WITH THE SIDE BOLTS

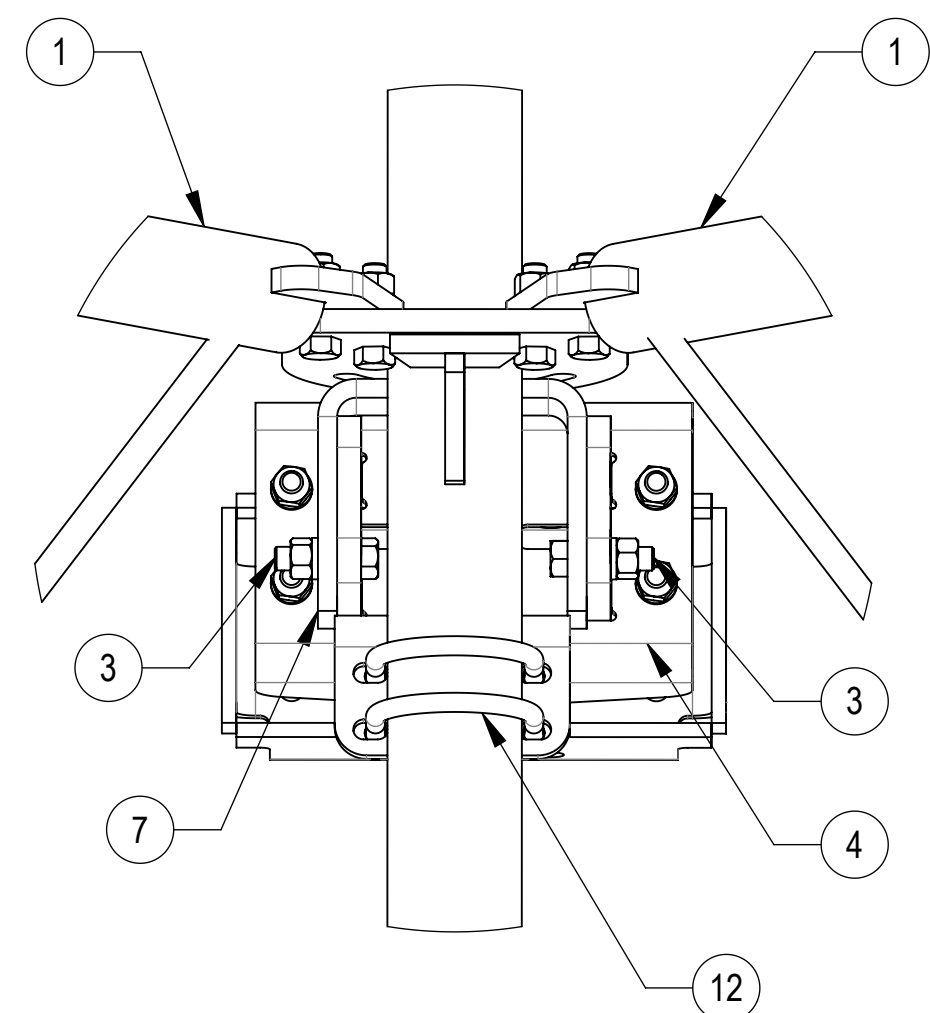

**DETAIL ISO TOP ROTATED VIEW**  
SCALE 1 : 5

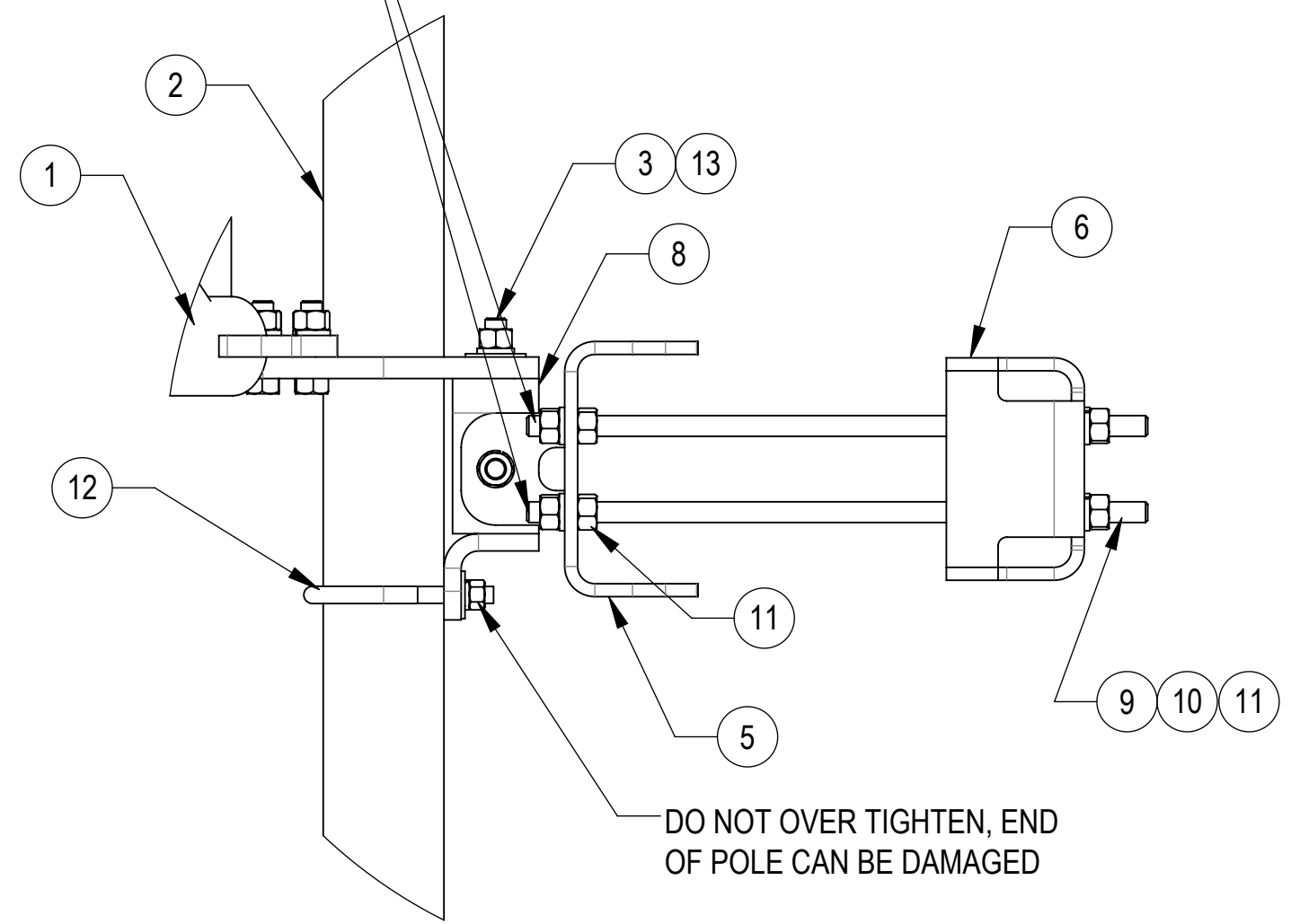

**DETAIL E**  
SCALE 1 : 5

DO NOT OVER TIGHTEN, END OF POLE CAN BE DAMAGED

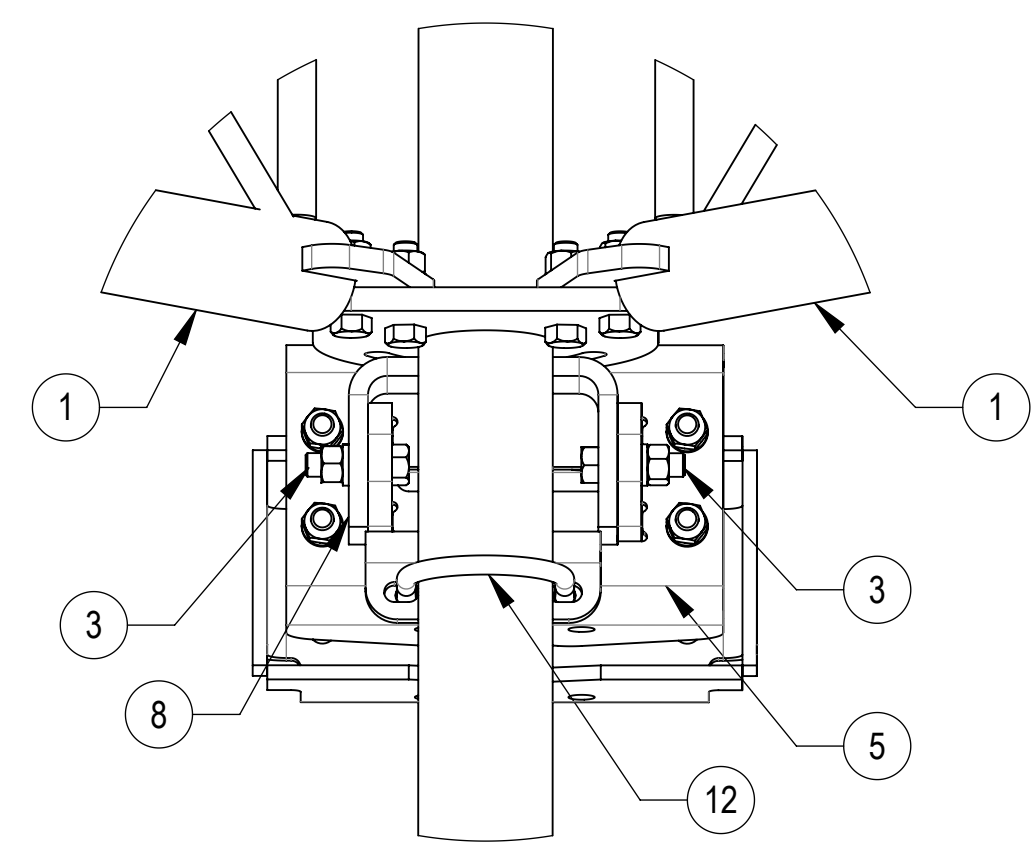

**DETAIL ISO BOTTOM ROTATED VIEW**  
SCALE 1 : 5

COMMSCOPE, INC. OF NORTH CAROLINA				
TITLE SF,15',(4)2.88"X126"-PIPES-PIM-SPACED				
SIZE <b>C</b>	SCALE <b>1:21</b>	DOCUMENT NO. <b>SFG23RHDXL15-4-126</b>		
		DRAWING		SHEET
		VERSION	STATUS	REVISION
		00	RE	A
				4 OF 5

4

3

2

1

4

3

2

1

**ACCESSORIES ORDERED SEPARATELY:**

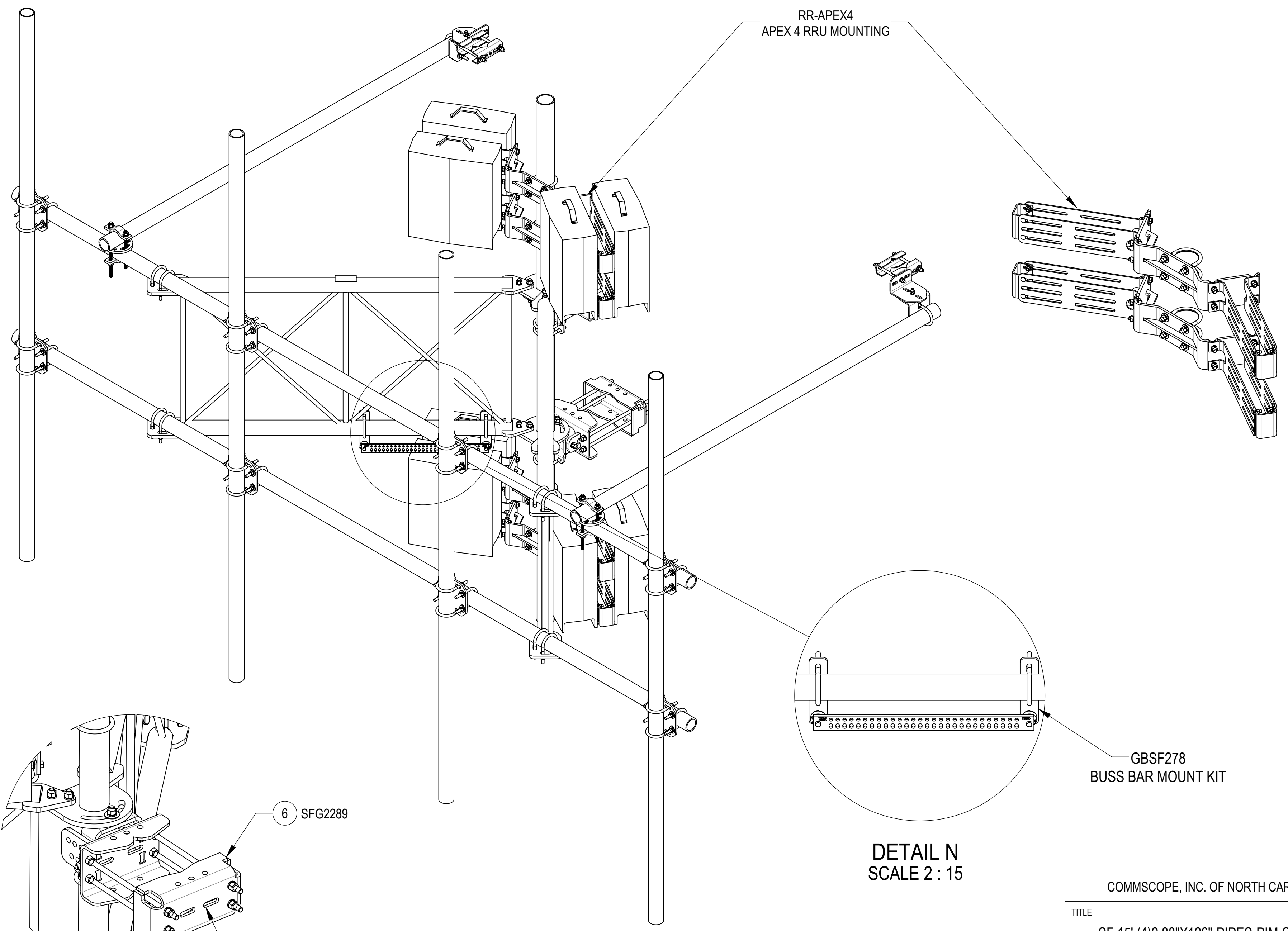

6 SFG2289

RR-APEX4  
APEX 4 RRU MOUNTING

GBSF278  
BUSS BAR MOUNT KIT

DETAIL N  
SCALE 2 : 15

SLOTS ALLOW FOR MOUNTING OF  
RRU OR OTHER EQUIPMENT

COMMSCOPE, INC. OF NORTH CAROLINA				
TITLE SF, 15', (4) 2.88" X 126" - PIPES - PIM - SPACED				
SIZE <b>C</b>	SCALE <b>1:12</b>	DOCUMENT NO. <b>SFG23RHDXL15-4-126</b>		
		DRAWING		SHEET
		VERSION	STATUS	REVISION
		00	RE	A
				5 OF 5

4

3

2

1