

- 1.0 GENERAL NOTES
 - 1.1 ALL METRIC DIMENSIONS ARE IN BRACKETS [X.X]
 - 1.2 FOR PATENT INFO: <https://www.cs-pat.com>
- 2.0 DESIGN NOTES
- 3.0 MANUFACTURING/SPECIAL REQUIREMENTS
 - 3.1 TIGHTEN ALL BOLTS SECURING FLAT PLATES BY THE TURN-OF-NUT METHOD. TIGHTEN ALL U-BOLTS USING TURN-OF-NUT METHOD WITH ATTENTION TO LEAVE EQUAL DISTANCE AND EQUAL FORCE ON EACH LEG OF THE U-BOLT.
- 4.0 TEST
- 5.0 PACKAGING
 - 5.1 PACKAGING SHALL MEET COMMSCOPE REQUIREMENTS PER DOCUMENT IS-PL-3005
 - 5.2 PRINTED DOCUMENT TO BE PLACED INSIDE POLYBAG AND THEN IN SHIPPING CONTAINER
 - 5.3 EXTRA HARDWARE MAYBE SUPPLIED, BAGGED AND SHIPPED

REVISIONS			
REV.	DESCRIPTION	DATE	APPROVED
D	NEW DESIGN	AW 31MAR05	
E	CORRECTED QTY FOR HARDWARE AND PIPE	YMENG 01MAR23	BCROSS 40166974CMO

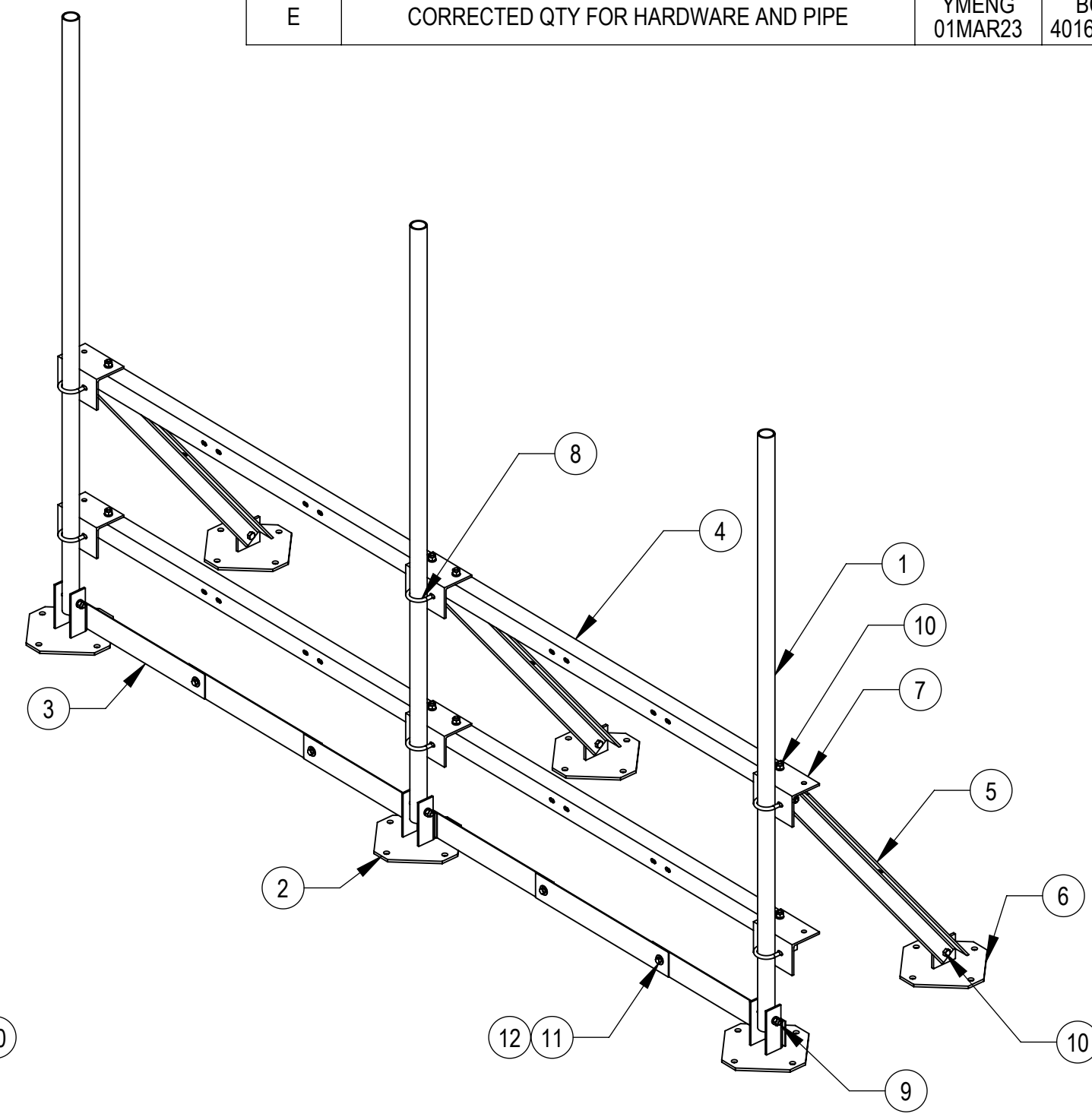
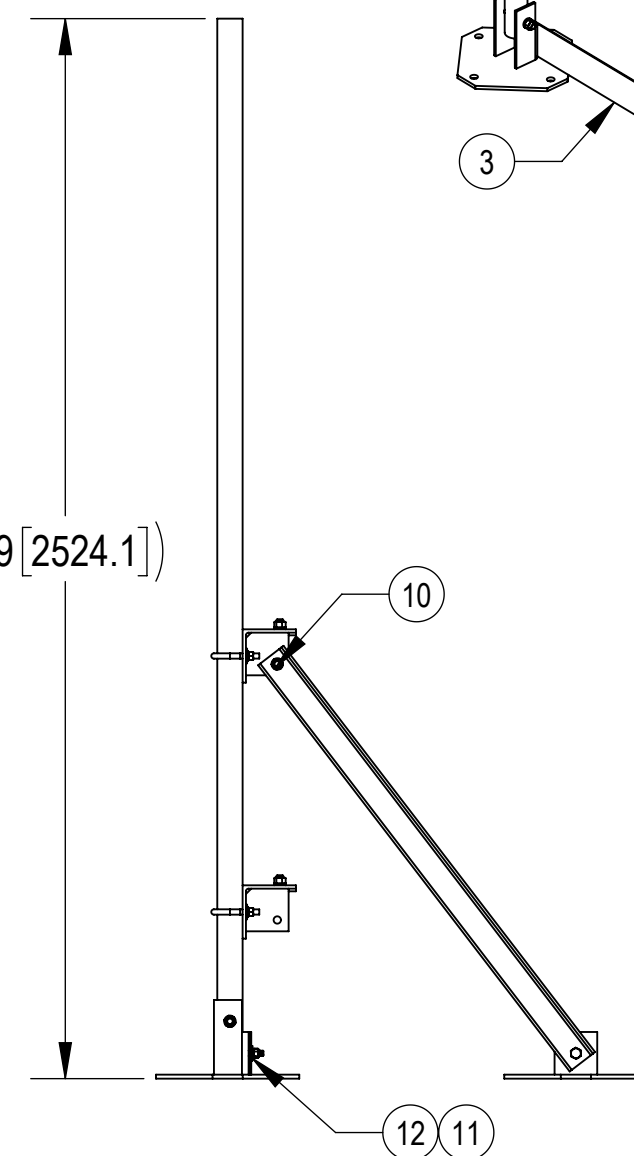
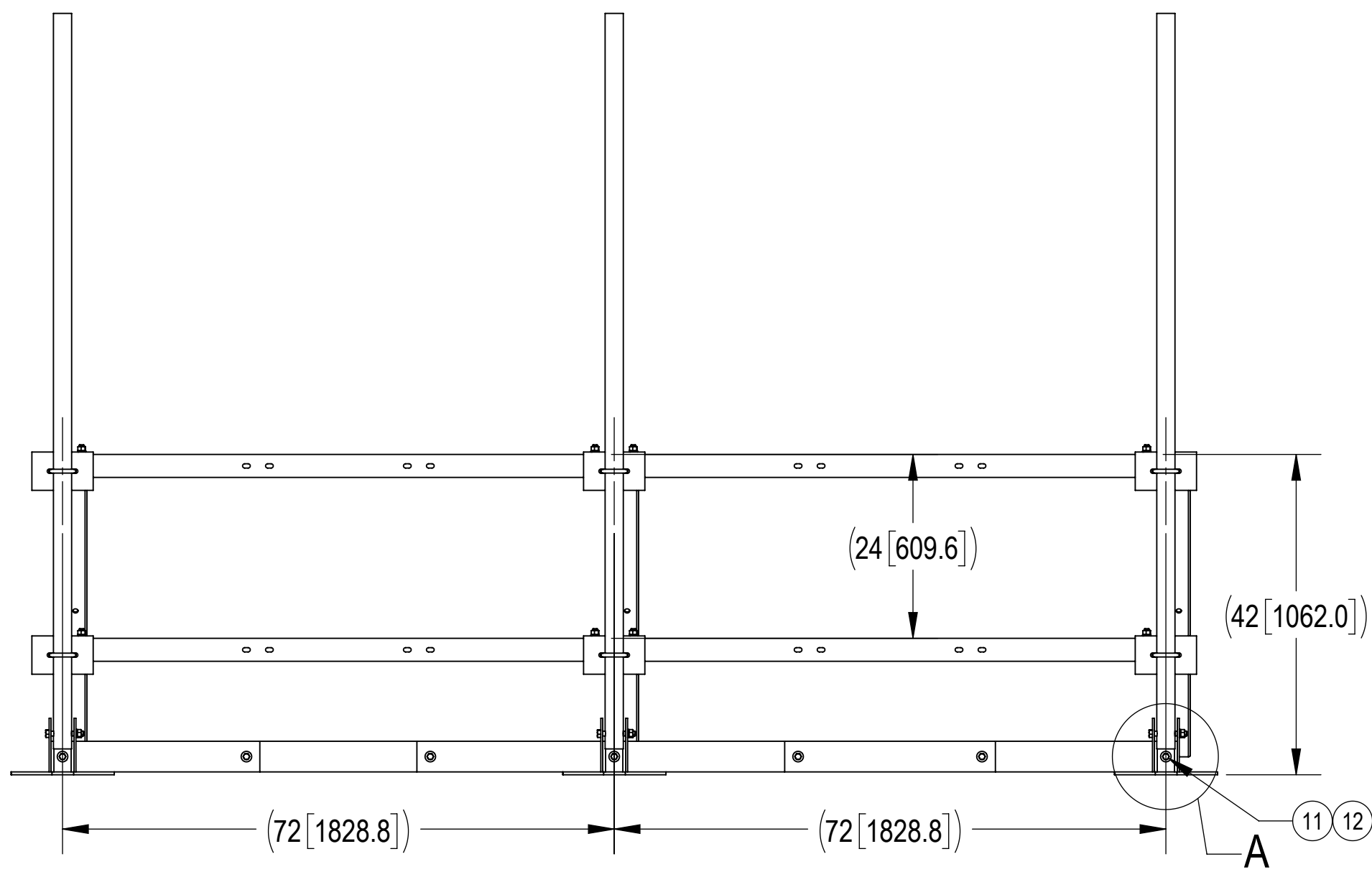

COMPONENT PART NUMBERS PROVIDED FOR ASSEMBLY PURPOSES;
INDIVIDUAL COMPONENTS MAY BE SHIPPED AS PARTS WITHIN AN INCLUDED KIT.

ITEM	PART NO.	DESCRIPTION	QTY.	WEIGHT	NOTE NO.
1	WTRTA32	96" VERTICAL PIPE	3	36.93 LBS	
2	WTRTA19	WELDED FOOT	3	16.49 LBS	
3	WTRTA27	LONG TOE BOARD SECTION	6	3.79 LBS	
4	WTRTA26	ANGLE, 6'	4	27.76 LBS	
5	WTRTA25	KICKER ANGLE	3	19.18 LBS	
6	WTRTA20	REAR FOOT	3	14.56 LBS	
7	WTRTA21	WELDED BRACKET	6	8.34 LBS	
8	GUB-4240	1/2" X 2-1/2" X 4" GALV U-BOLT	6	0.56 LBS	
9	GB-05445	5/8" X 4-1/2" GALV BOLT KIT	3	0.48 LBS	
10	GB-05145	5/8" X 1-1/2" GALV BOLT KIT	14	0.22 LBS	
11	GB-04145	1/2" X 1-1/2" GALV BOLT KIT	7	0.13 LBS	
12	GWF-04	1/2" GALV FLAT WASHER	14	0.04 LBS	

WT-SMA12-3-96 VIEW

DENSITY	lbs/in ³
MASS	lbs
VOLUME	in ³
SURFACE AREA	in ²
HEIGHT	99"
LENGTH	152"
WIDTH	46"

COMMSCOPE, INC. OF NORTH CAROLINA			
TOLERANCES		SAP MATERIAL MASTER	
1 PLACE .X[X] ± .06[1.5]	3 PLACE .XXX[X] ± .010[0.25]		
2 PLACE .XX[X] ± .03[0.76]	ANGLES ± 2°		
FINISH		MATERIAL	
UNLESS OTHERWISE SPECIFIED DIMENSIONS ARE IN INCHES INTERPRET PER ANSI Y 14.5M-1994	NAME	DATE	TITLE
	CE AW	31MAR05	12' WATER TOWER ROOF TOP SECTOR FRAME
	RW YMENG	03/01/2023	
	AD BCROSS	03/06/2023	
	RE LMCADOWEL	03/07/2023	
ECN 40166974CMO			
SCALE	DOCUMENT NO.	WT-SMA12 SERIES	
1:32			
SIZE	Auth Group	INSL	MODEL
C			
VERSION	STATUS	REVISION	VERSION
00	RE	E	00
DRAWING		STATUS	REVISION
		RE	E
			SHEET
			1 OF 2

4

3

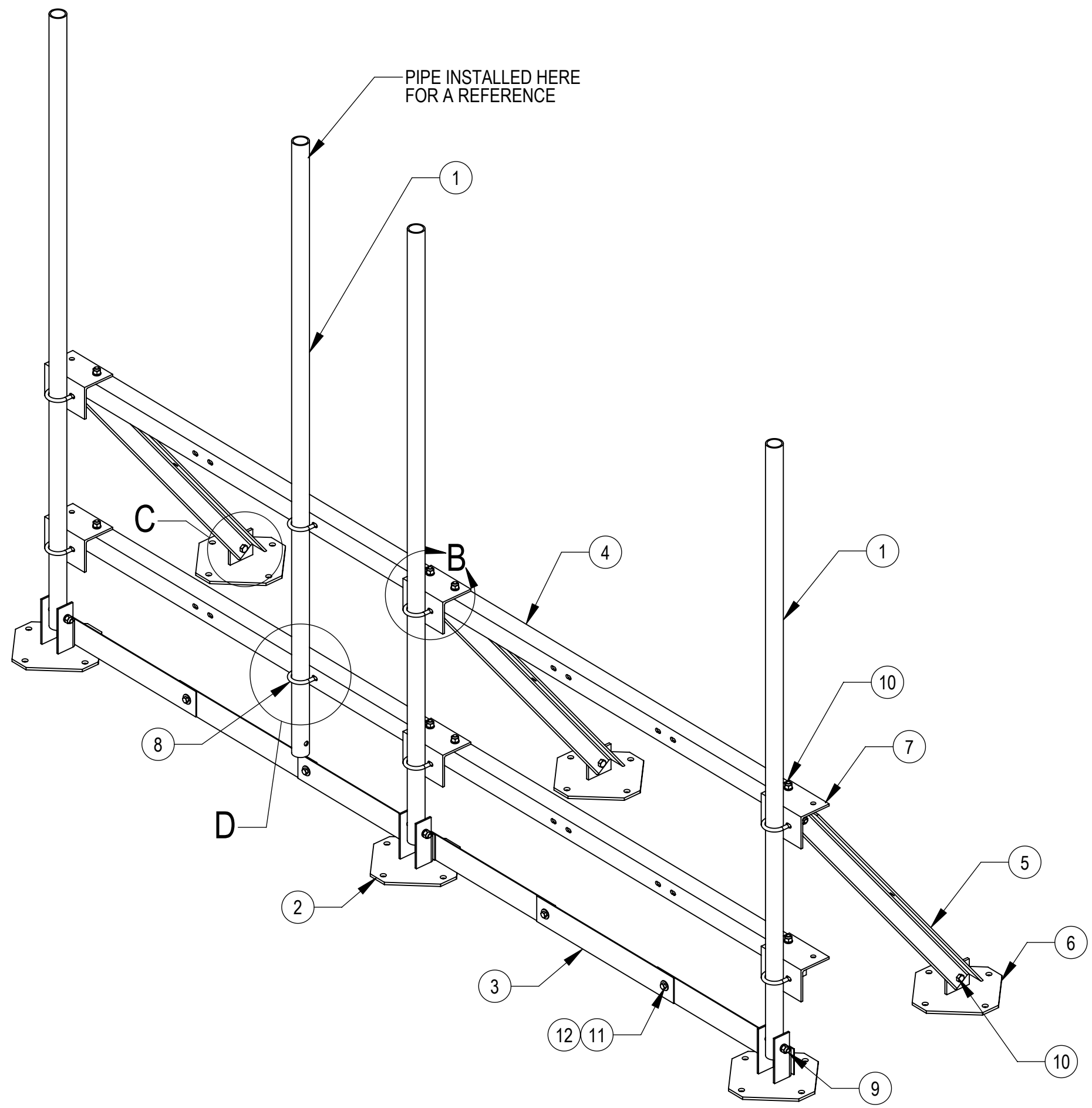
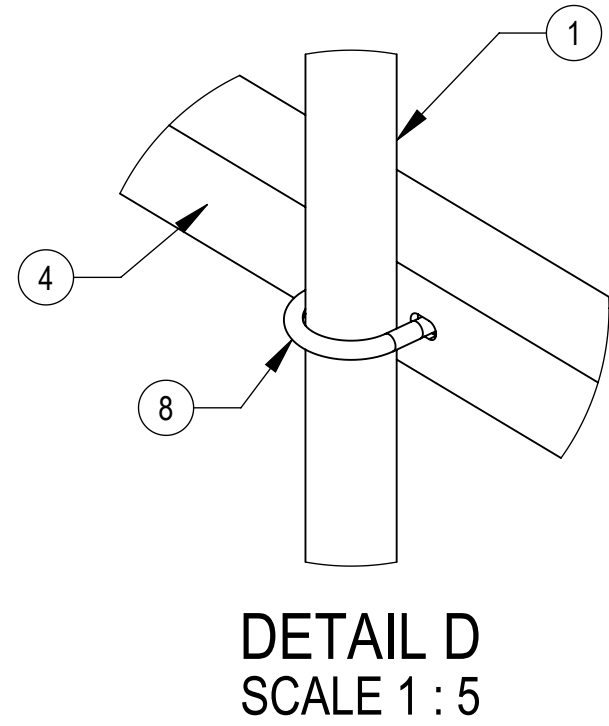
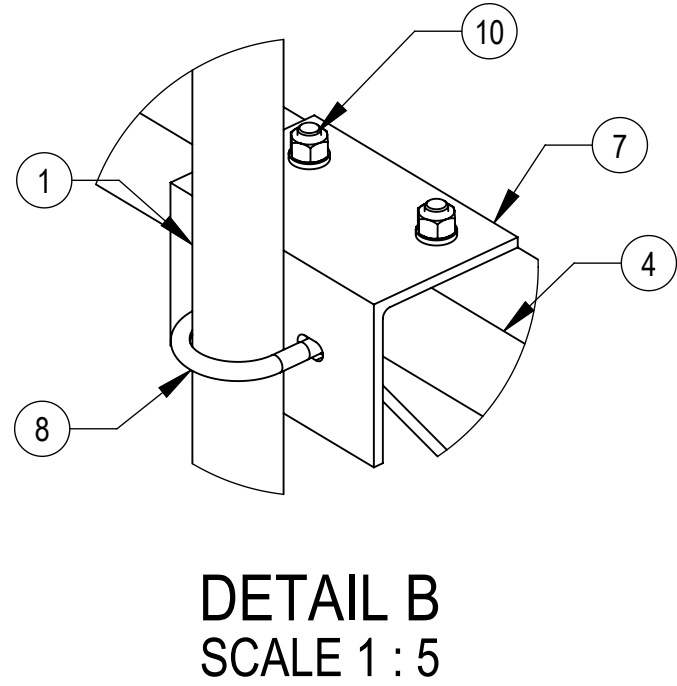
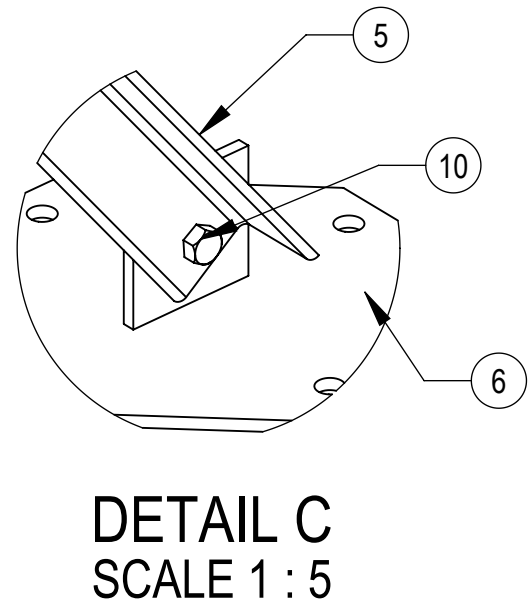
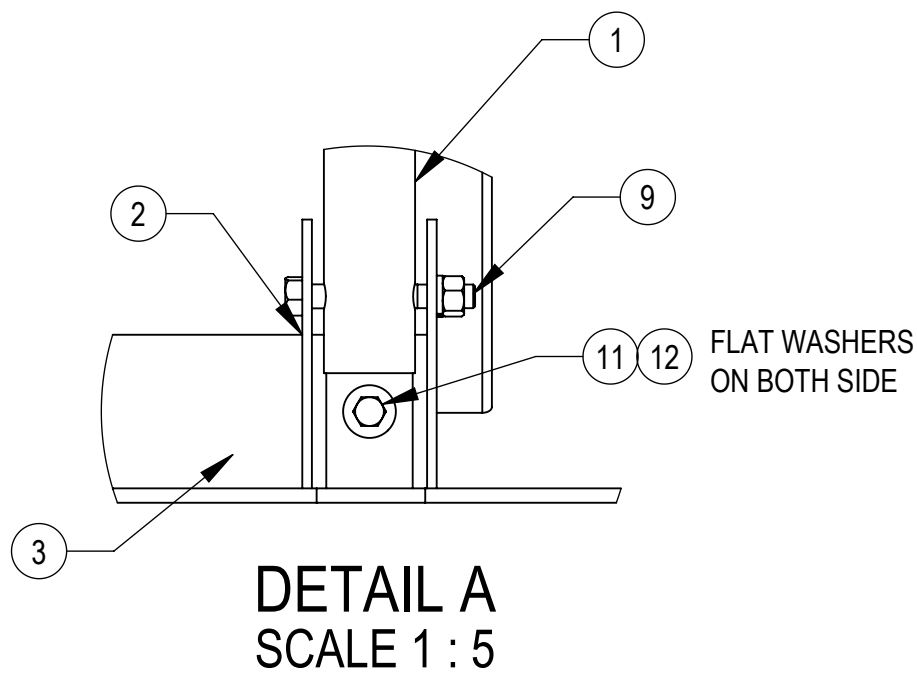

2

1



COMPONENT PART NUMBERS PROVIDED FOR ASSEMBLY PURPOSES;
INDIVIDUAL COMPONENTS MAY BE SHIPPED AS PARTS WITHIN AN INCLUDED KIT.

ITEM	PART NO.	DESCRIPTION	QTY.	WEIGHT	NOTE NO.
1	WTRTA32	96" VERTICAL PIPE	4	36.93 LBS	
2	WTRTA19	WELDED FOOT	3	16.49 LBS	
3	WTRTA27	LONG TOE BOARD SECTION	6	3.79 LBS	
4	WTRTA26	ANGLE, 6'	4	27.76 LBS	
5	WTRTA25	KICKER ANGLE	3	19.18 LBS	
6	WTRTA20	REAR FOOT	3	14.56 LBS	
7	WTRTA21	WELDED BRACKET	6	8.34 LBS	
8	GUB-4240	1/2" X 2-1/2" X 4" GALV U-BOLT	8	0.56 LBS	
9	GB-05445	5/8" X 4-1/2" GALV BOLT KIT	3	0.48 LBS	
10	GB-05145	5/8" X 1-1/2" GALV BOLT KIT	14	0.22 LBS	
11	GB-04145	1/2" X 1-1/2" GALV BOLT KIT	7	0.13 LBS	
12	GWF-04	1/2" GALV FLAT WASHER	14	0.04 LBS	

COMMSCOPE, INC. OF NORTH CAROLINA					
TITLE 12' WATER TOWER ROOF TOP SECTOR FRAME					
SIZE C	SCALE 1:32	DOCUMENT NO. WT-SMA12 SERIES			
 		DRAWING			SHEET 2 OF 2
		VERSION 00	STATUS RE	REVISION E	

© 2023 CommScope, Inc. Confidential

4

3

2

1