

REVISIONS			
REV.	DESCRIPTION	DATE	APPROVED
A	ECR 40149936CMO; RELEASE TO PRODUCTION PER EAO 611029.	05DEC22 GJH	SSG/QZY

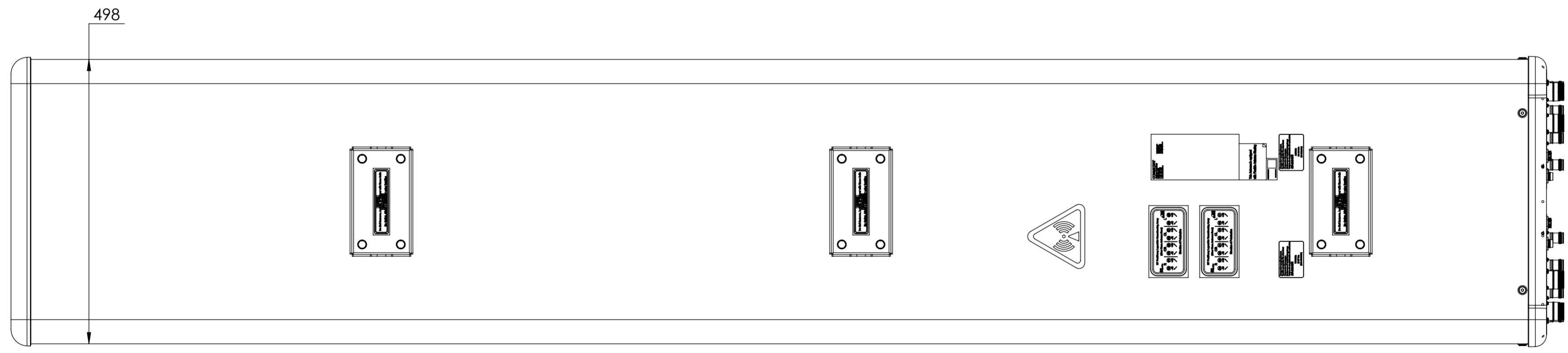
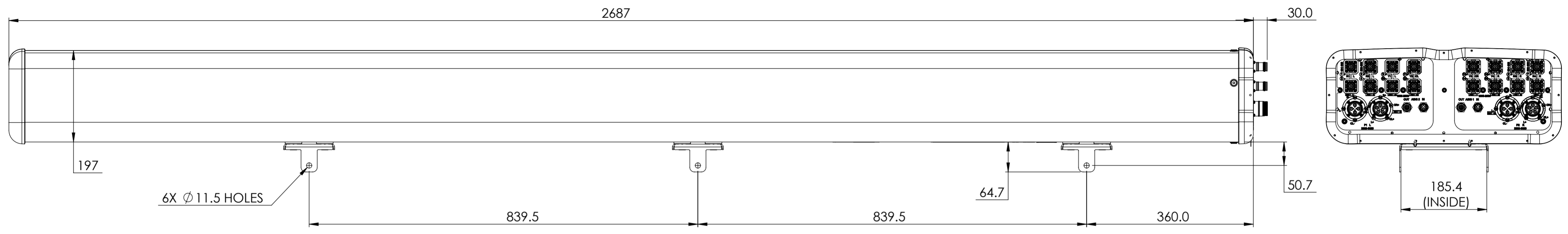

EEGGV4Q4Q465DR10

COMMScope, INC. OF NORTH CAROLINA

TOLERANCES		SAP MATERIAL MASTER													
0 PLACE X ±	2 PLACE .XX ±														
1 PLACE .X ±	ANGLES ±														
FINISH		MATERIAL													
UNLESS OTHERWISE SPECIFIED DIMENSIONS ARE IN MILLIMETERS INTERPRET PER ISO STANDARDS HANDBOOK TECHNICAL DRAWINGS VOLUMES 1 & 2, THIRD EDITION (2002)		<table border="1"> <thead> <tr> <th>NAME</th> <th>DATE</th> <th>TITLE</th> </tr> </thead> <tbody> <tr> <td>CE JGU2</td> <td>12/5/2022</td> <td rowspan="4">PRODUCT DRAWING</td> </tr> <tr> <td>RW JGU2</td> <td>12/08/2022</td> </tr> <tr> <td>AD SS1224</td> <td>12/08/2022</td> </tr> <tr> <td>RE XYHANG</td> <td>12/08/2022</td> </tr> </tbody> </table>		NAME	DATE	TITLE	CE JGU2	12/5/2022	PRODUCT DRAWING	RW JGU2	12/08/2022	AD SS1224	12/08/2022	RE XYHANG	12/08/2022
NAME	DATE	TITLE													
CE JGU2	12/5/2022	PRODUCT DRAWING													
RW JGU2	12/08/2022														
AD SS1224	12/08/2022														
RE XYHANG	12/08/2022														
DENSITY	g/mm ³	SCALE	DOCUMENT NO.												
MASS	grams	1:6	EEGGV4Q4Q465DR10-L												
VOLUME	mm ³														
SURFACE AREA	mm ²														
HEIGHT		SIZE	Auth Group BSA												
LENGTH		A2	MODEL												
WIDTH			VERSION STATUS REVISION												
			00 RE A												
			DRAWING												
			VERSION STATUS REVISION												
			00 RE A												
			SHEET												
			1 OF 1												