

REV	ECO	DWN	DATE
A	20060949	CDZ	12-JUN-00
-	-----	---	-----

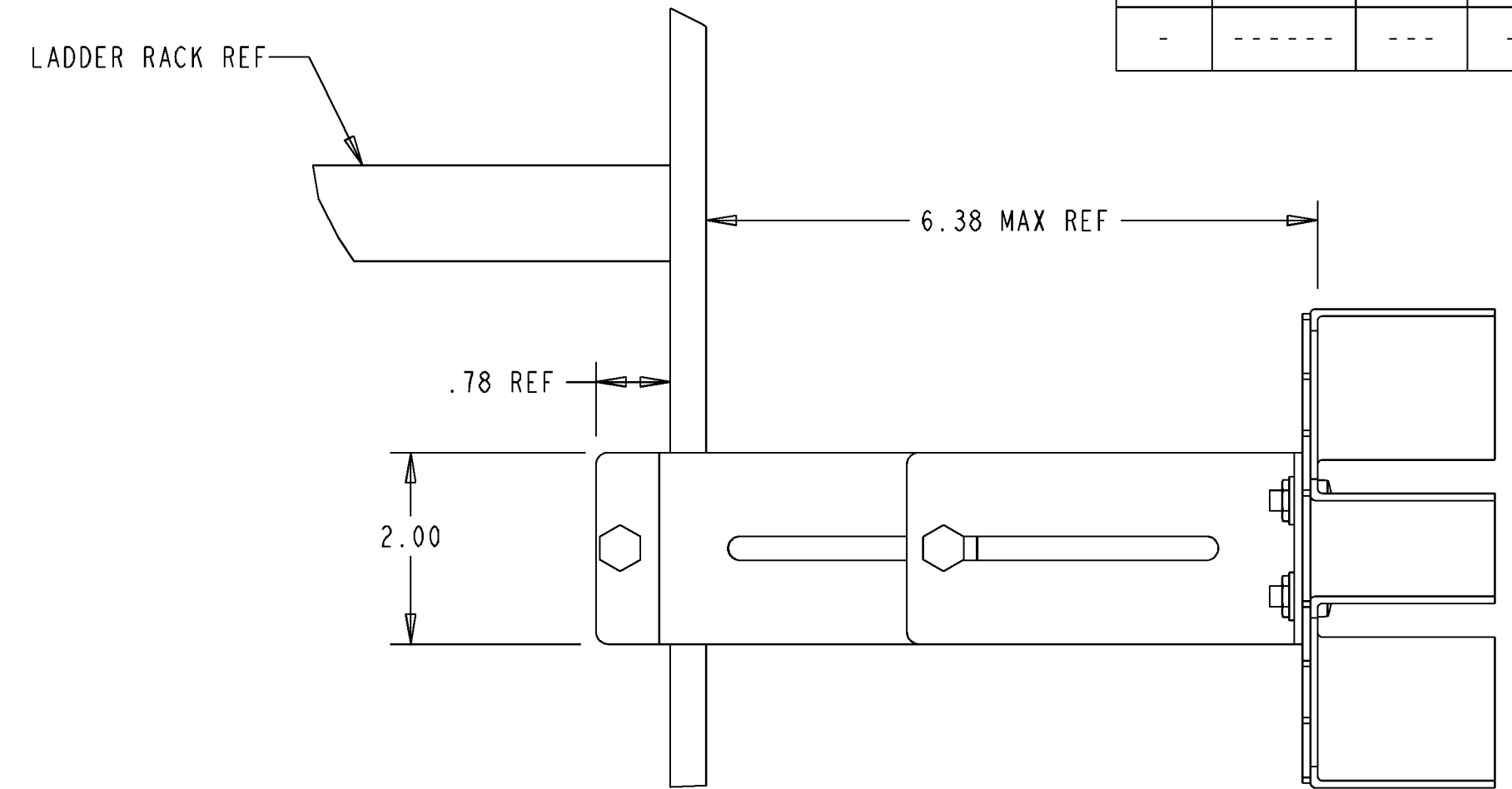

2" FGS REF
(2"Y SHOWN AS REFERENCE)

BRACKET CONFIGURATION "A"

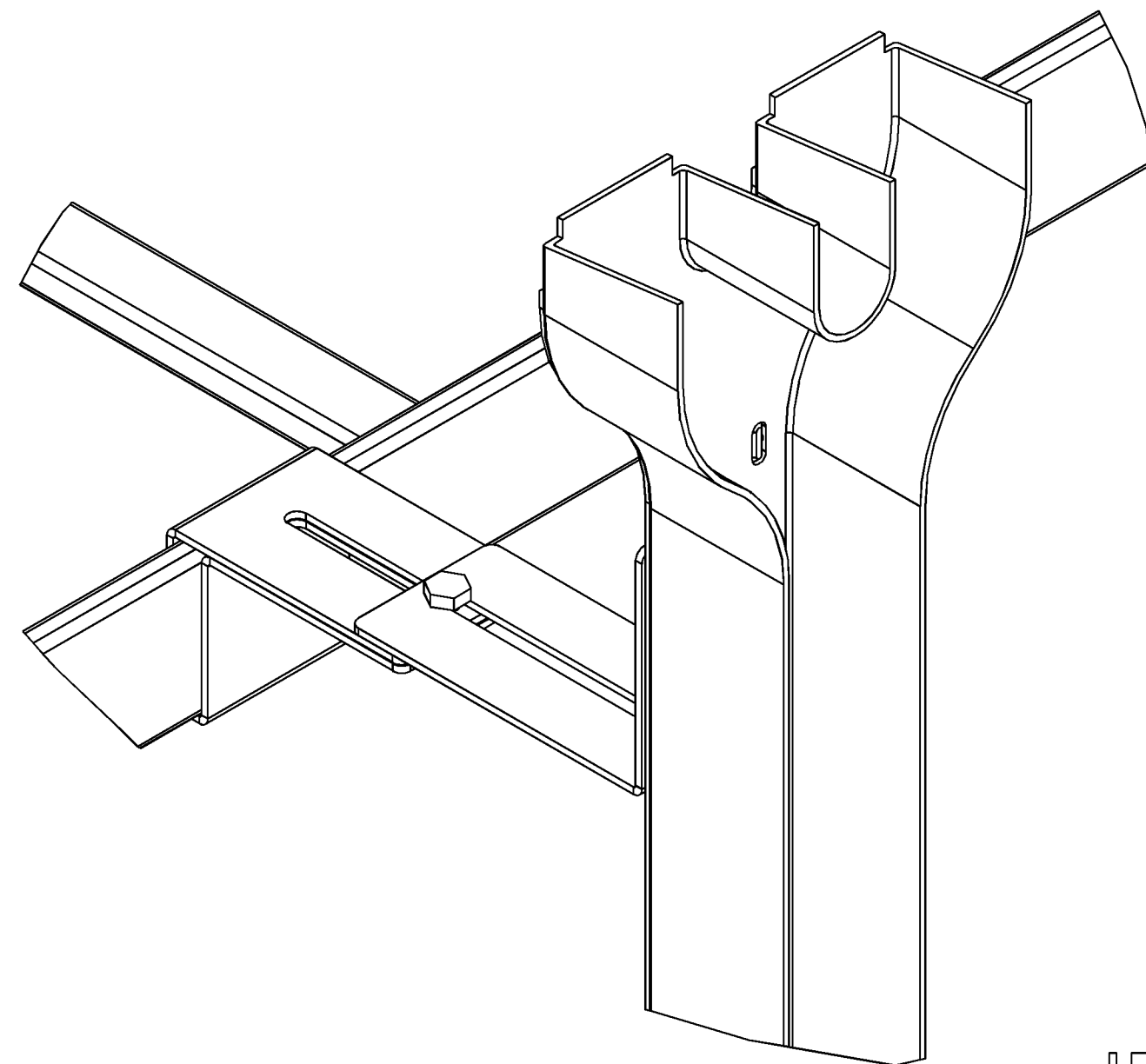
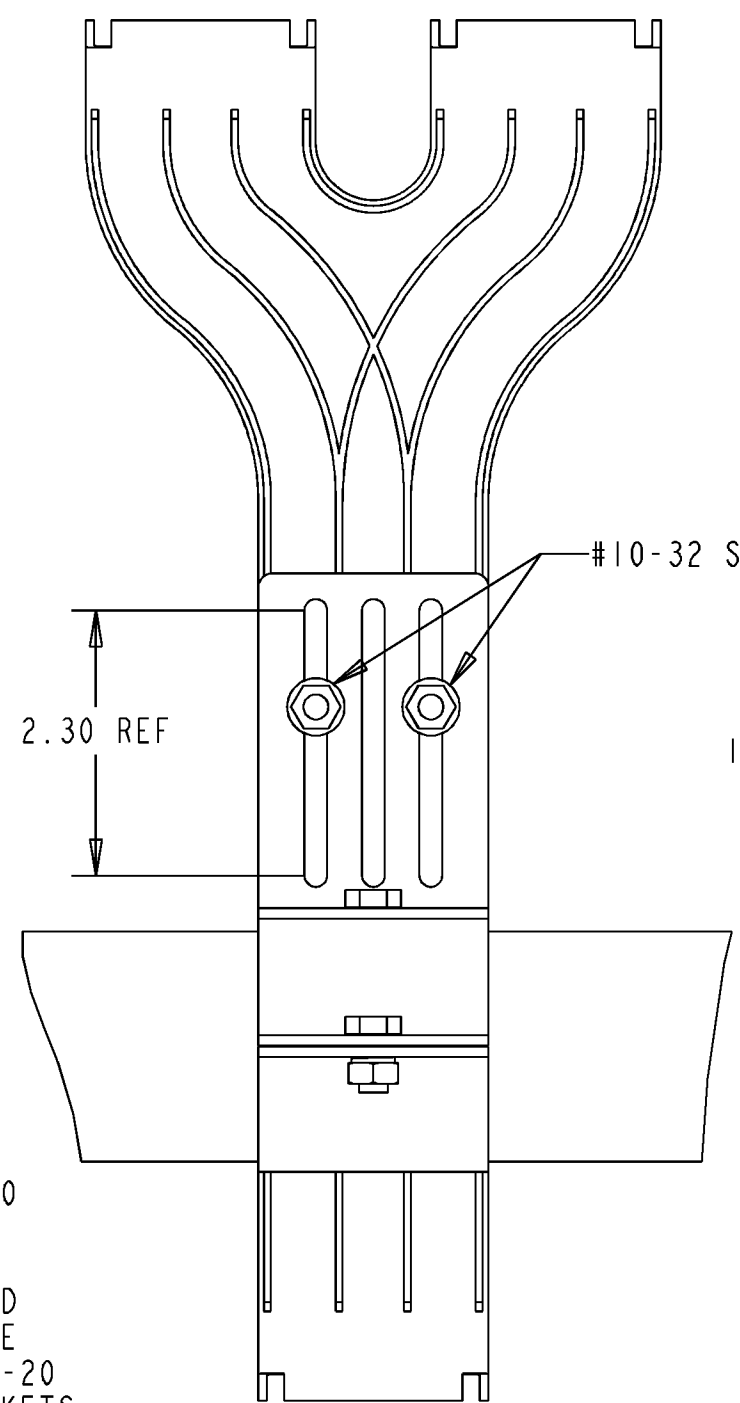

#10-32 SCREW, SPLIT LOCK WASHER, NUT

2.30 REF

1/4-20 SCREW, SPLIT LOCK WASHER, NUT

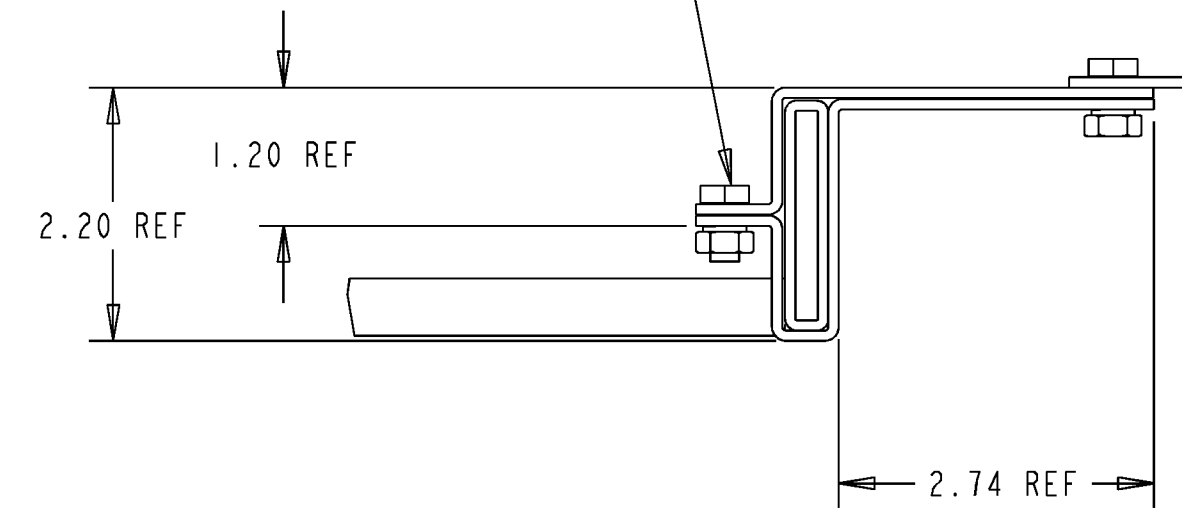

NOTES:

- KIT INCLUDES THE FOLLOWING:
 - (1) BRACKET, 2" FGS/Y MOUNT
 - (1) BRACKET, TOP
 - (1) BRACKET, BOTTOM
 - (2) #10-32 SCREW
 - (2) #10 SPLIT LOCK WASHER
 - (2) #10-32 NUT
 - (2) 1/4-20 HEX HEAD SCREW
 - (2) 1/4 SPLIT LOCK WASHER
 - (2) 1/4-20 NUT
- USE BRACKET CONFIGURATION "A" (SHEET 1) IF FIBERGUIDE IS DESIRED TO BE LOCATED IN THE RANGE OF APPROX. 2.83 TO 6.38 INCHES FROM LADDER RACK.
- USE BRACKET CONFIGURATION "B" (SHEET 2) IF FIBERGUIDE IS DESIRED TO BE LOCATED IN THE RANGE OF APPROX. 1.01 TO 2.83 INCHES FROM LADDER RACK.
- PLACE THE BRACKET BOTTOM AND TOP ON THE LADDER RACK, AS SHOWN, PER CONFIGURATION REQUIRED. INSERT (1) 1/4-20 HEX HEAD SCREW THROUGH THE HOLES IN THE SHORT TABS ON THE BRACKETS. ASSEMBLE (1) 1/4 SPLITLOCK WASHER AND (1) 1/4-20 NUT TO THE SCREW, AND TIGHTEN NUT COMPLETELY.
- PLACE THE 2"FGS/Y MOUNT BRACKET ON THE TOP OF THE ASSEMBLED BRACKETS ON THE LADDER RACK, SINGLE SLOT DOWNWARDS. LOCATE THE MOUNT BRACKET TO THE DESIRED LOCATION. INSERT (1) 1/4-20 HEX HEAD SCREW THROUGH THE SLOTS IN ALL (3) ASSEMBLED BRACKETS. ASSEMBLE (1) 1/4 SPLITLOCK WASHER AND (1) 1/4-20 NUT TO THE SCREW, AND TIGHTEN NUT COMPLETELY.
- MATE THE BACK OF THE 2"FGS COMPONENT TO THE 3-SLOTTED SIDE OF THE 2"FGS/Y MOUNT BRACKET. INSERT (2) #10-32 SCREWS THROUGH THE 2"FGS AND BRACKET. ASSEMBLE (1) #10 SPLITLOCK WASHER AND (1) #10-32 NUT TO EACH OF THE (2) SCREWS. TIGHTEN THE (2) NUTS COMPLETELY.

CATALOG #: FGS-HLDR-C



INFORMATION ON THIS DOCUMENT IS PROPRIETARY TO ADC AND SHALL NOT BE USED, COPIED, REPRODUCED OR DISCLOSED IN WHOLE OR IN PART WITHOUT WRITTEN CONSENT OF ADC.		TITLE 2" WYE BRACKET INSTALL DRW	
TOLERANCE UNLESS OTHERWISE SPECIFIED .XX: ±.02 XXX: ±.010 ANGULAR: ±2°	C SIZE	DRAWING NUMBER 1114274	A REV
THIRD ANGLE PROJECTION DO NOT SCALE DRAWING	ENGR: KEVIN HRUBY DWN: CRAIG ZELASKO	SHT. 1 OF 2	

REV	ECO	DWN	DATE

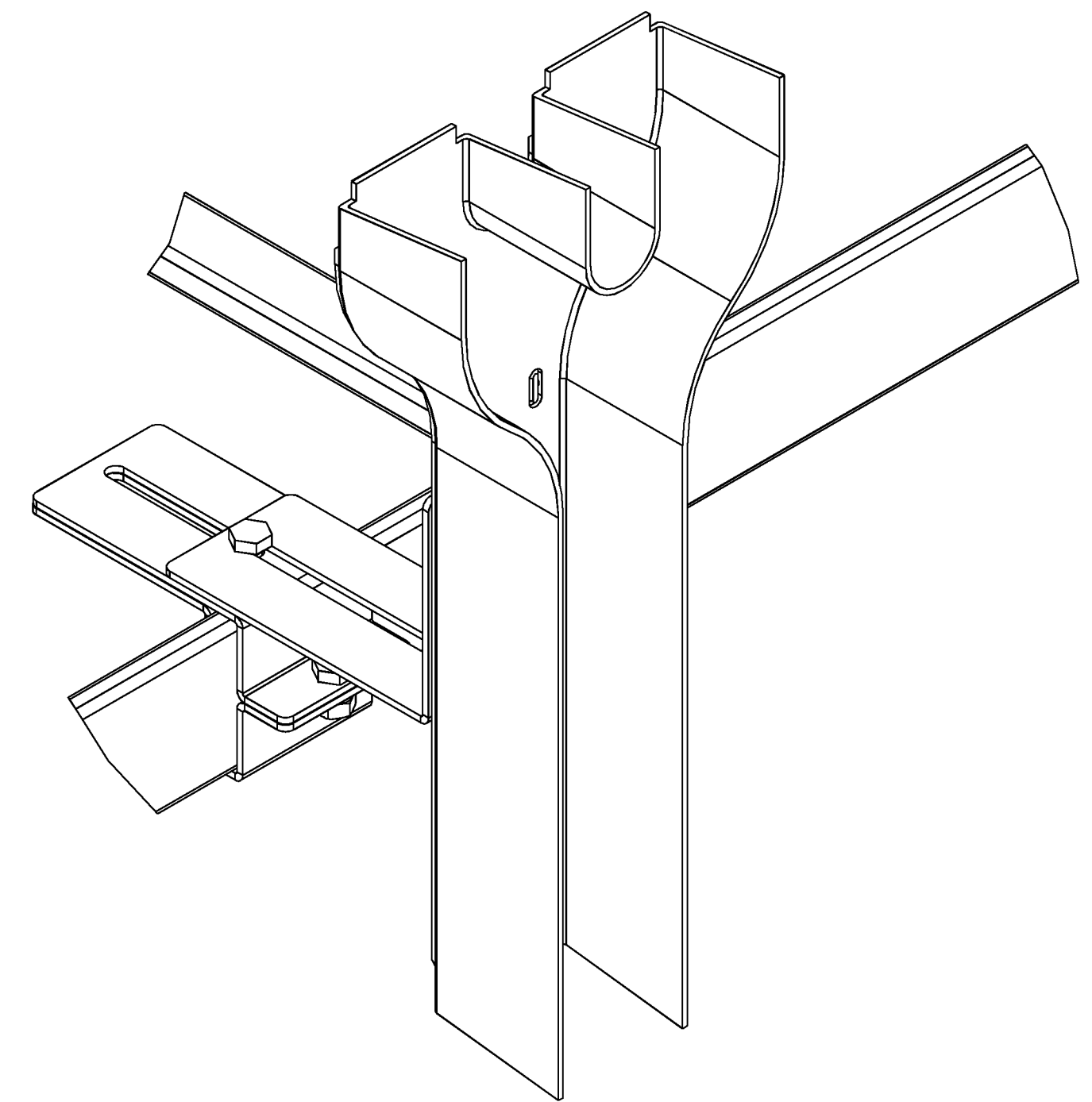
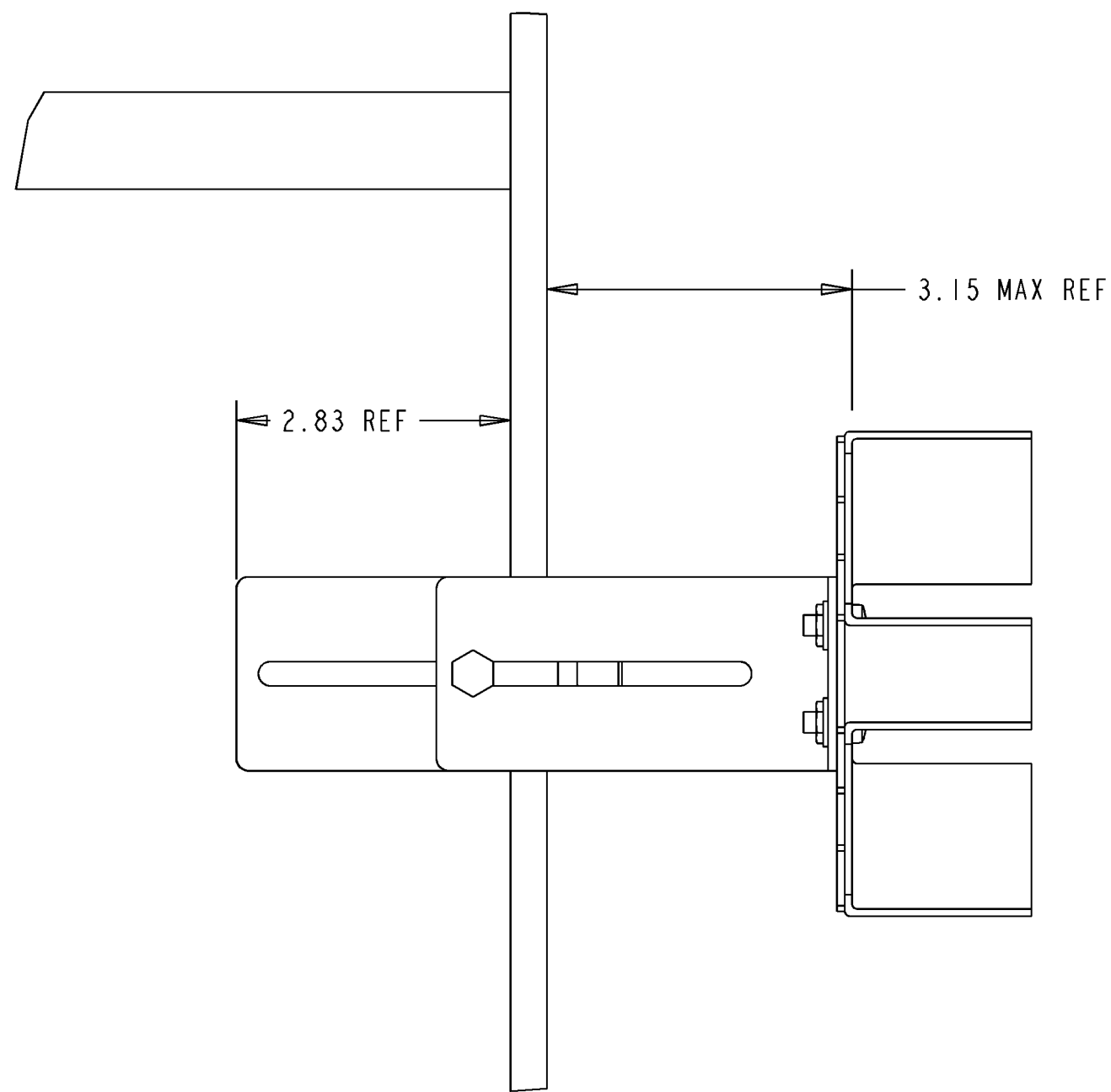

BRACKET CONFIGUATION "B"

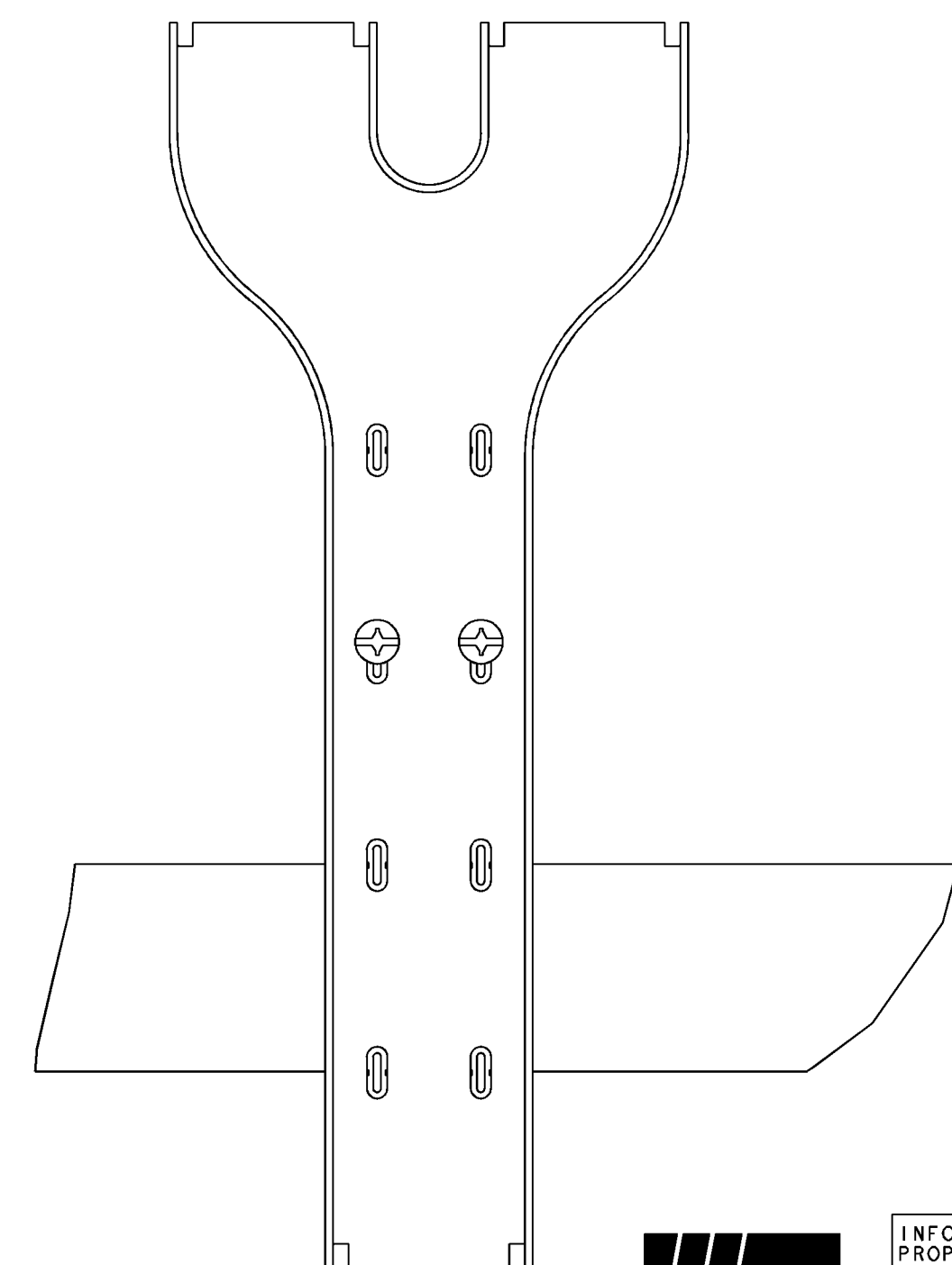
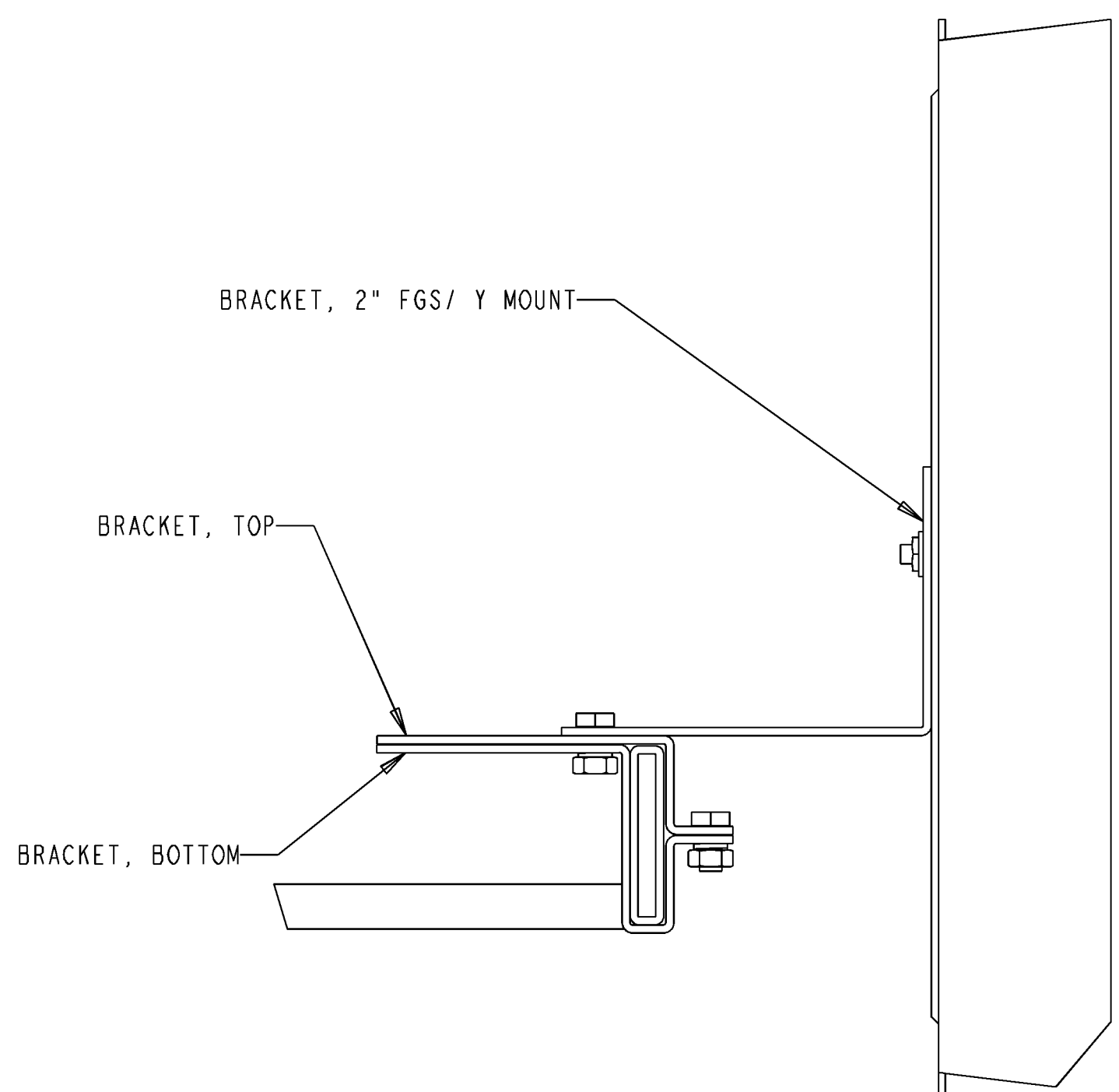

<small>INFORMATION ON THIS DOCUMENT IS PROPRIETARY TO ADC AND SHALL NOT BE USED, COPIED, REPRODUCED OR DISCLOSED IN WHOLE OR IN PART WITHOUT WRITTEN CONSENT OF ADC.</small>		TITLE 2" WYE BRACKET INSTALL DRW	
<small>TOLERANCE UNLESS OTHERWISE SPECIFIED</small> .XX: ±.02 .XXX: ±.010 ANGULAR: ±2°	C <small>SIZE</small>	<small>DRAWING NUMBER</small> 1114274	A <small>REV</small>
<small>THIRD ANGLE PROJECTION</small> 	<small>DO NOT SCALE DRAWING</small>	<small>ENGR: KEVIN HRUBY</small> <small>DWN: CRAIG ZELASKO</small>	<small>SHT. 2 OF 2</small>