

NOTES:

- 1.0 GENERAL NOTES
  - 1.1 ALL METRIC DIMENSIONS ARE IN BRACKETS [X.X]
  - 1.2 MARK PART WITH IDENTIFICATION NUMBER
- 2.0 DESIGN NOTES
  - 2.1 FITS TOWER LEGS 8" OD, 8" ANGLE 60° AND 6" ANGLE 90°  
ALL DIMENSIONS SHOWN ARE FOR REFERENCE ONLY  
ALL CONNECTIONS ARE ADJUSTABLE. FINAL INSTALLED APPLICATION DICTATES FINISHED DIMENSIONS.
- 3.0 MANUFACTURING/SPECIAL REQUIREMENTS
  - 3.1 TORQUE HARDWARE TO 60 FT-LBS
  - 3.2 FINISH: GALVANIZE ASTM A123
- 4.0 TEST
- 5.0 PACKAGING
  - 5.1 PACKAGING SHALL MEET COMMSCOPE REQUIREMENTS PER DOCUMENT IS-PL-3005

| REVISIONS |            |                            |     |          |
|-----------|------------|----------------------------|-----|----------|
| REV.      | ECN        | DESCRIPTION                | BY  | DATE     |
| A         | 8000026456 | INITIAL RELEASE            | QDL | 09/26/17 |
| B         | 11410PC    | MTC3932-0063 WAS MTC393213 | RJC | 7/9/2021 |

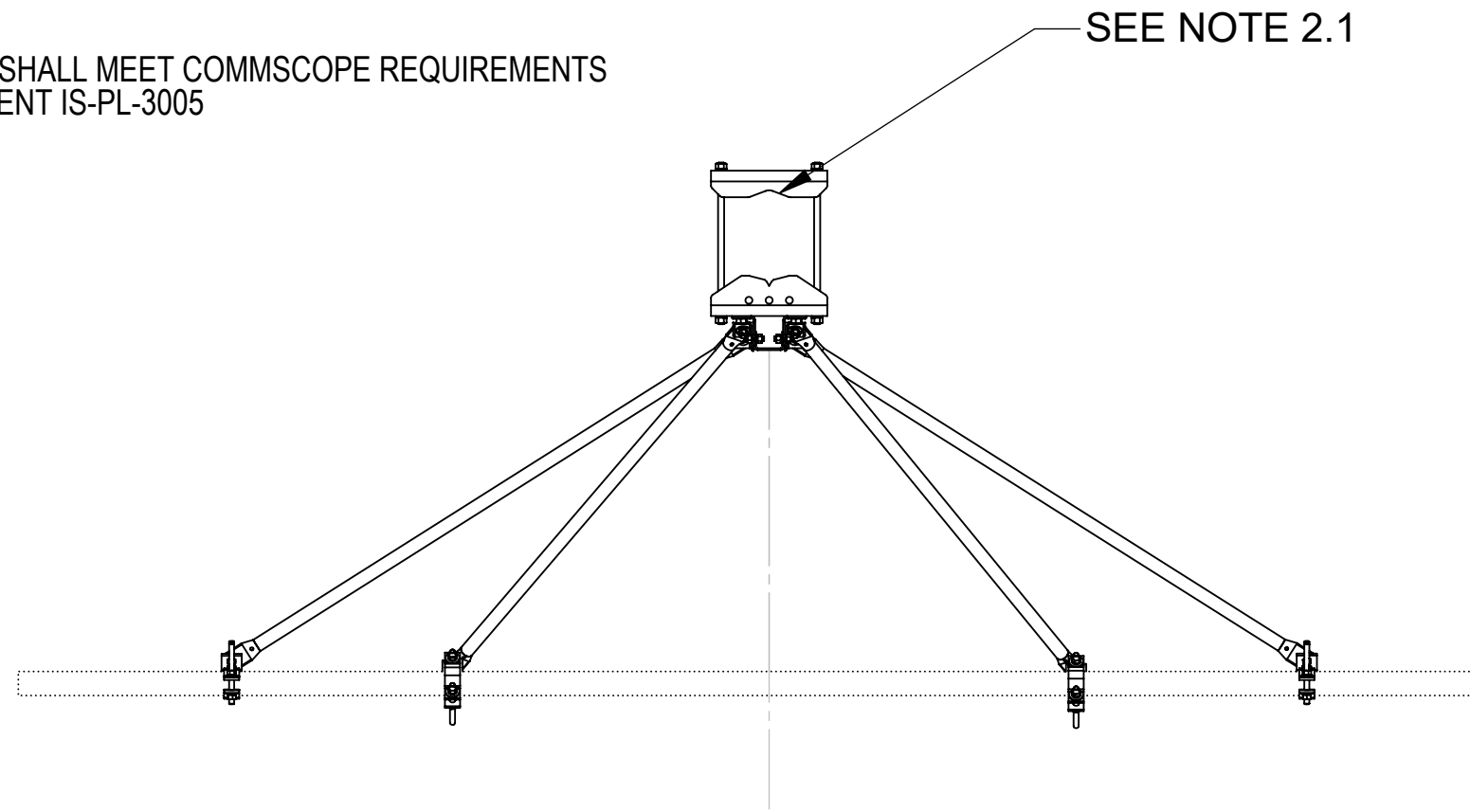

UP TO ±30° AZIMUTH ADJUSTMENT OFF APEX

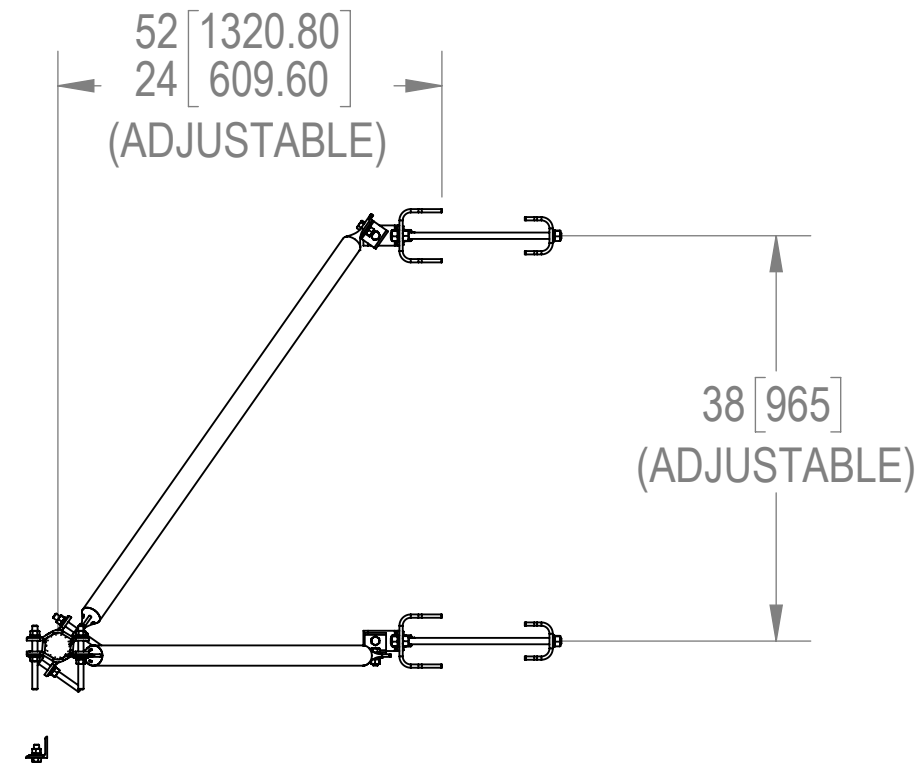
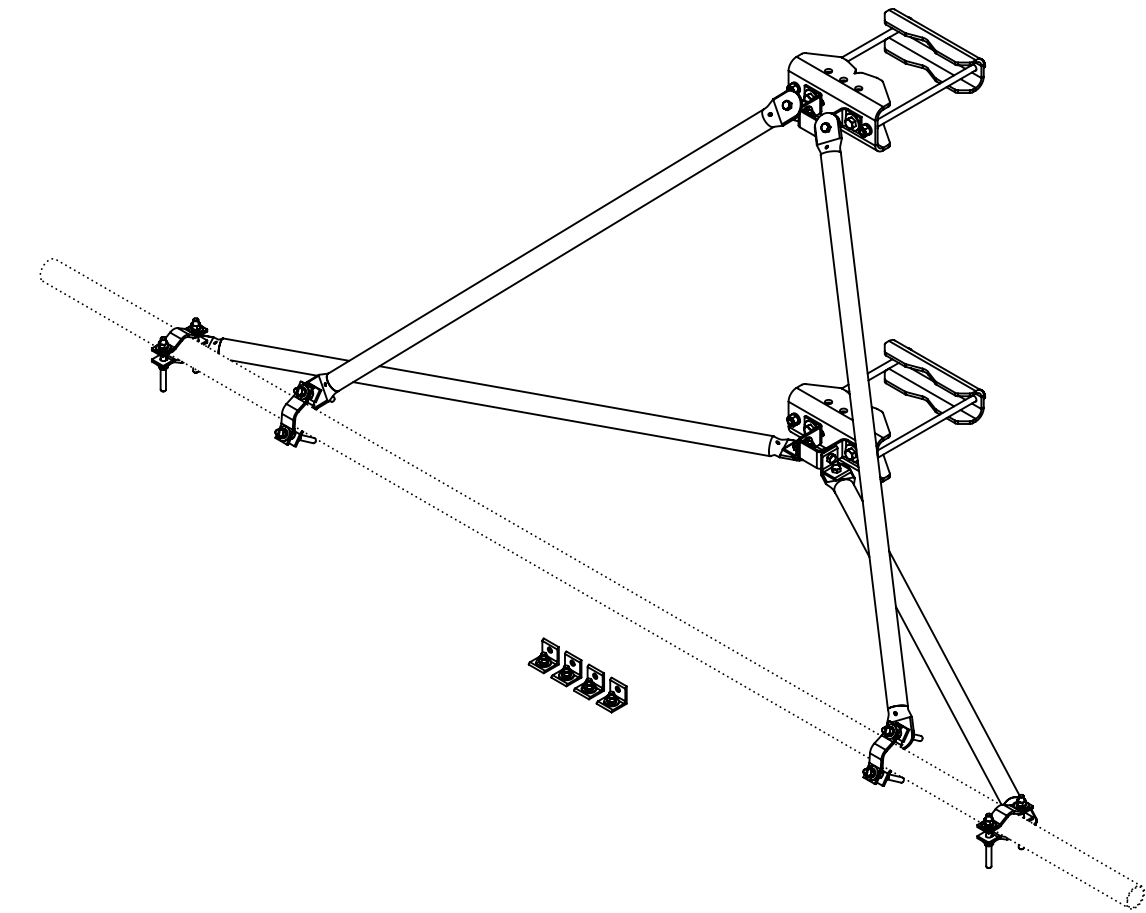
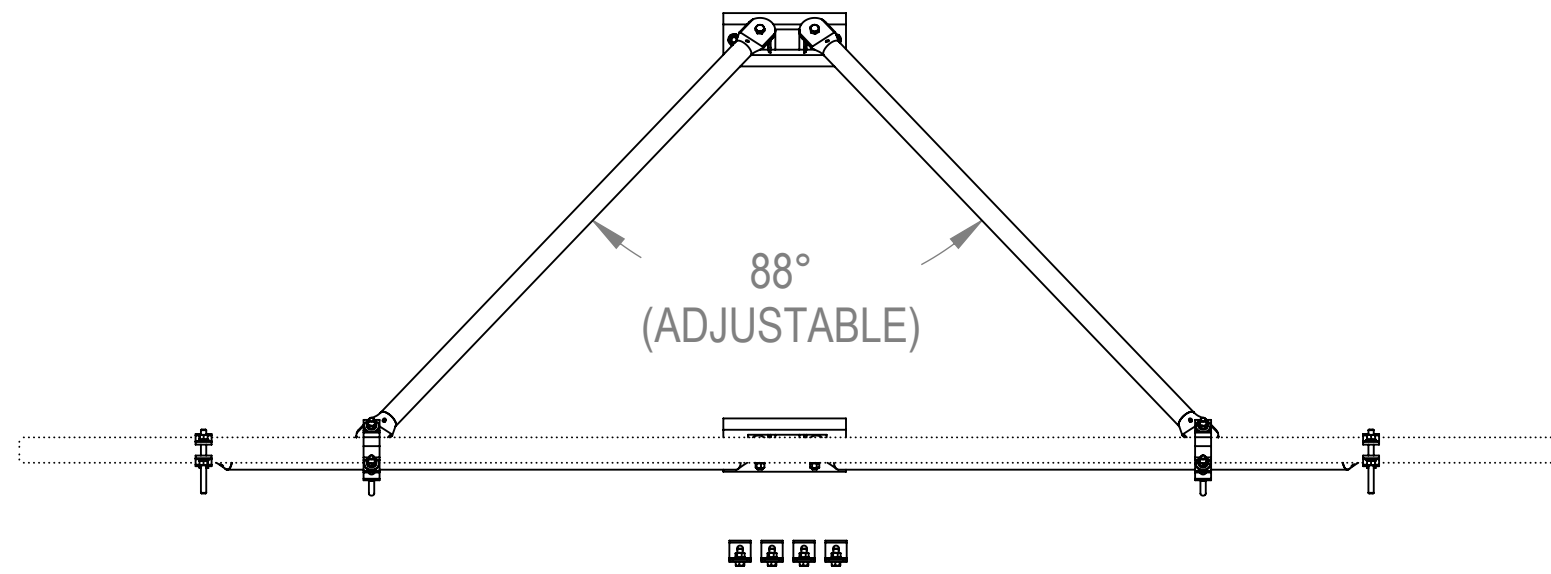

|   |            |                        |            |  |                               |         |        |          |        |
|---|------------|------------------------|------------|--|-------------------------------|---------|--------|----------|--------|
| <b>COMMSCOPE, INC. OF NORTH CAROLINA</b>  |            |                        |            |  |                               |         |        |          |        |
| TOLERANCES  |            |                        |            |  | SAP MATERIAL MASTER           |         |        |          |        |
| 0 PLACE X ± .25   |            | 2 PLACE .XX ± 0.06     |            |  | <b>VSRDUAL-TS-B-HD</b>        |         |        |          |        |
| 1 PLACE .X ± 0.12   |            | ANGLES ± 2°            |            |  |                               |         |        |          |        |
| FINISH<br>GAVL A123   |            |                        |            |  | MATERIAL<br>A500; A1011/A1018 |         |        |          |        |
| UNLESS OTHERWISE SPECIFIED DIMENSIONS ARE IN INCHES INTERPRET PER ANSI Y 14.5M-1994 | CE         | RJC                    | 07/09/21   | <b>UNIVERSAL REINFORCEMENT KIT<br/>SCTR FRM HD</b> |                               |         |        |          |        |
|   | RW         | BCAMPBELLCON           | 07/15/2021 |  |                               |         |        |          |        |
|   | AD         | BCROSS                 | 08/23/2021 |  |                               |         |        |          |        |
|   | RE         | BCROSS                 | 08/23/2021 |  |                               |         |        |          |        |
|   | ECN        | 11410PC                |            |  |                               |         |        |          |        |
| SCALE   |            | DOCUMENT NO.           |            |  |                               |         |        |          |        |
| 1:18  |            | <b>VSRDUAL-TS-B-HD</b> |            |  |                               |         |        |          |        |
| SIZE  | Auth Group | INSL                   | MODEL      |  |                               | DRAWING |        |          |        |
| <b>C</b>  |            |                        | VERSION    | STATUS   | REVISION                      | VERSION | STATUS | REVISION | SHEET  |
|   |            |                        | 00         | RE   | B                             | 00      | RE     | B        | 1 OF 3 |

|              |        |                     |
|--------------|--------|---------------------|
| DENSITY      | 0.28   | lbs/in <sup>3</sup> |
| MASS         | 136.87 | lbs                 |
| VOLUME       | 484.90 | in <sup>3</sup>     |
| SURFACE AREA |        | in <sup>2</sup>     |
| HEIGHT       |        |                     |
| LENGTH       |        |                     |
| WIDTH        |        |                     |

NOTES:

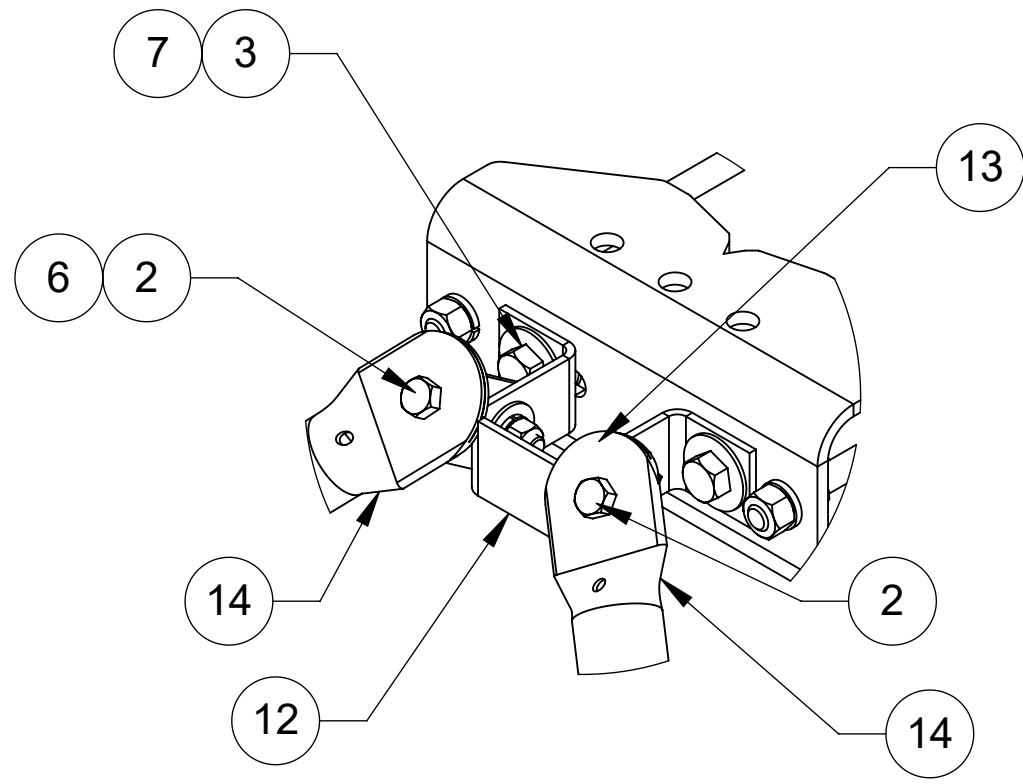

DETAIL A  
SCALE 1 : 4

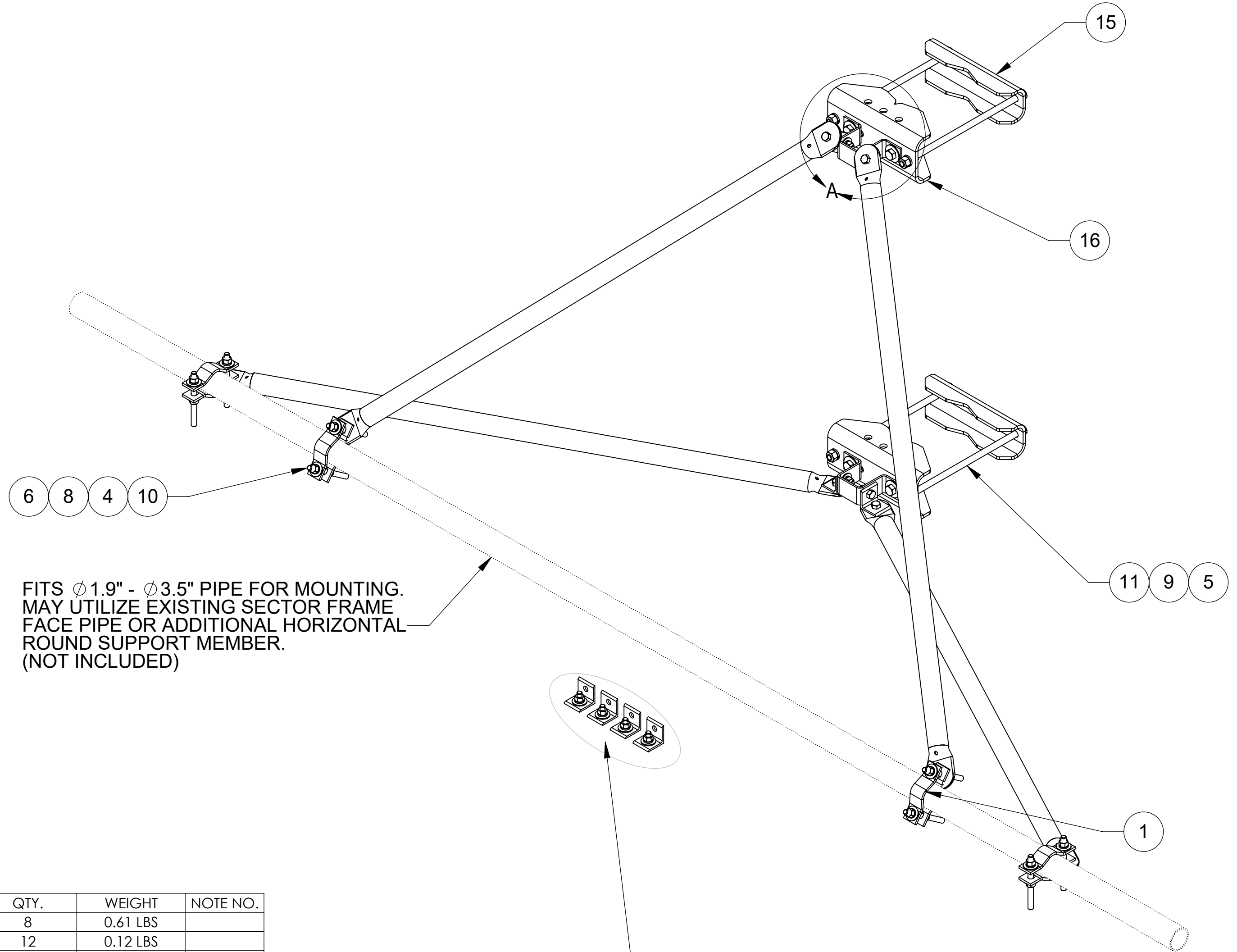

FITS  $\phi$  1.9" -  $\phi$  3.5" PIPE FOR MOUNTING.  
MAY UTILIZE EXISTING SECTOR FRAME  
FACE PIPE OR ADDITIONAL HORIZONTAL  
ROUND SUPPORT MEMBER.  
(NOT INCLUDED)

PIVOT BRACKETS USED FOR ANGLE LEG APPLICATIONS  
WHEN MOUNT AZIMUTH IS NOT DIRECTLY OFF APEX  
**(SEE PAGE 3 FOR DETAILS)**

| ITEM | PART NO.     | DESCRIPTION                   | QTY. | WEIGHT    | NOTE NO. |
|------|--------------|-------------------------------|------|-----------|----------|
| 1    | ACP10        | 1.5" - 3.5" O.D. CLAMP HALF   | 8    | 0.61 LBS  |          |
| 2    | GB-04125     | 1/2" X 1-1/4" GALV BOLT KIT   | 12   | 0.12 LBS  |          |
| 3    | GB-05165     | 5/8" X 1-3/4" GALV BOLT KIT   | 4    | 0.24 LBS  |          |
| 4    | GN-04        | 1/2" GALV HEX NUT             | 16   | 0.04 LBS  |          |
| 5    | GN-05        | 5/8" GALV HEX NUT             | 12   | 0.08 LBS  |          |
| 6    | GWF-04       | 1/2" GALV FLAT WASHER         | 28   | 0.01 LBS  |          |
| 7    | GWF-05       | 5/8" GALV FLAT WASHER         | 8    | 0.06 LBS  |          |
| 8    | GWL-04       | 1/2" GALV LOCK WASHER         | 16   | 0.01 LBS  |          |
| 9    | GWL-05       | 5/8" GALV LOCK WASHER         | 8    | 0.03 LBS  |          |
| 10   | MT-379-6     | 1/2" X 6" GALV THREADED ROD   | 8    | 0.33 LBS  |          |
| 11   | MT-382-16    | 5/8" X 16" THREADED ROD       | 4    | 1.28 LBS  |          |
| 12   | MTC393210    | BRACKET, PIVOT ATTACHMENT     | 2    | 1.24 LBS  |          |
| 13   | MTC393211    | BRACKET, PIVOT                | 8    | 0.37 LBS  |          |
| 14   | MTC3932-0063 | ARM, SUPPORT, 1.9" OD; SCH 40 | 4    | 13.51 LBS |          |
| 15   | MTC397521    | CLAMP, BACK                   | 2    | 6.94 LBS  |          |
| 16   | MTC397522    | CLAMP, FRONT MOUNTING         | 2    | 10.02 LBS |          |

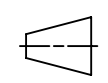
|   |                     |  |        |                 |
|---|---------------------|--|--------|-----------------|
| COMMSCOPE, INC. OF NORTH CAROLINA   |                     |  |        |                 |
| TITLE<br>UNIVERSAL REINFORCEMENT KIT SCTR FRM HD  |                     |  |        |                 |
| SIZE<br><b>C</b>  | SCALE<br><b>1:8</b> | DOCUMENT NO.<br><b>VSRDUAL-TS-B-HD</b> |        |                 |
| DRAWING   |                     | VERSION                                | STATUS | REVISION        |
|   |                     | 00                                     | RE     | B               |
|   |                     |  |        | SHEET<br>2 OF 3 |

4

3

2

1

NOTES:

**UP TO ±30° OFF APEX AZIMUTH ADJUSTMENT WHEN USING SUPPLIED PIVOT ANGLES ON FACE MOUT CLAMPS.**

D

D

C

C

B



B

A

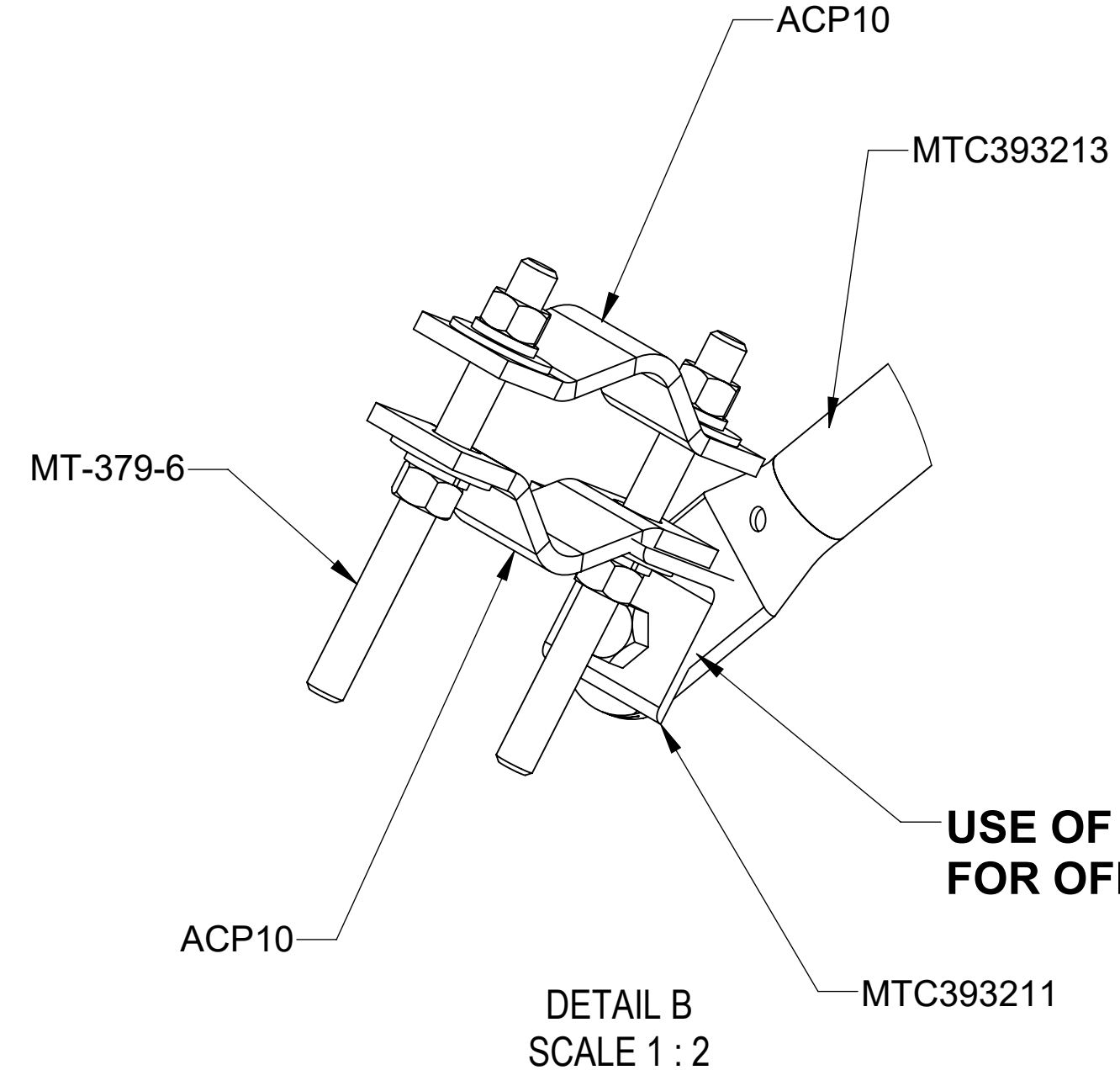
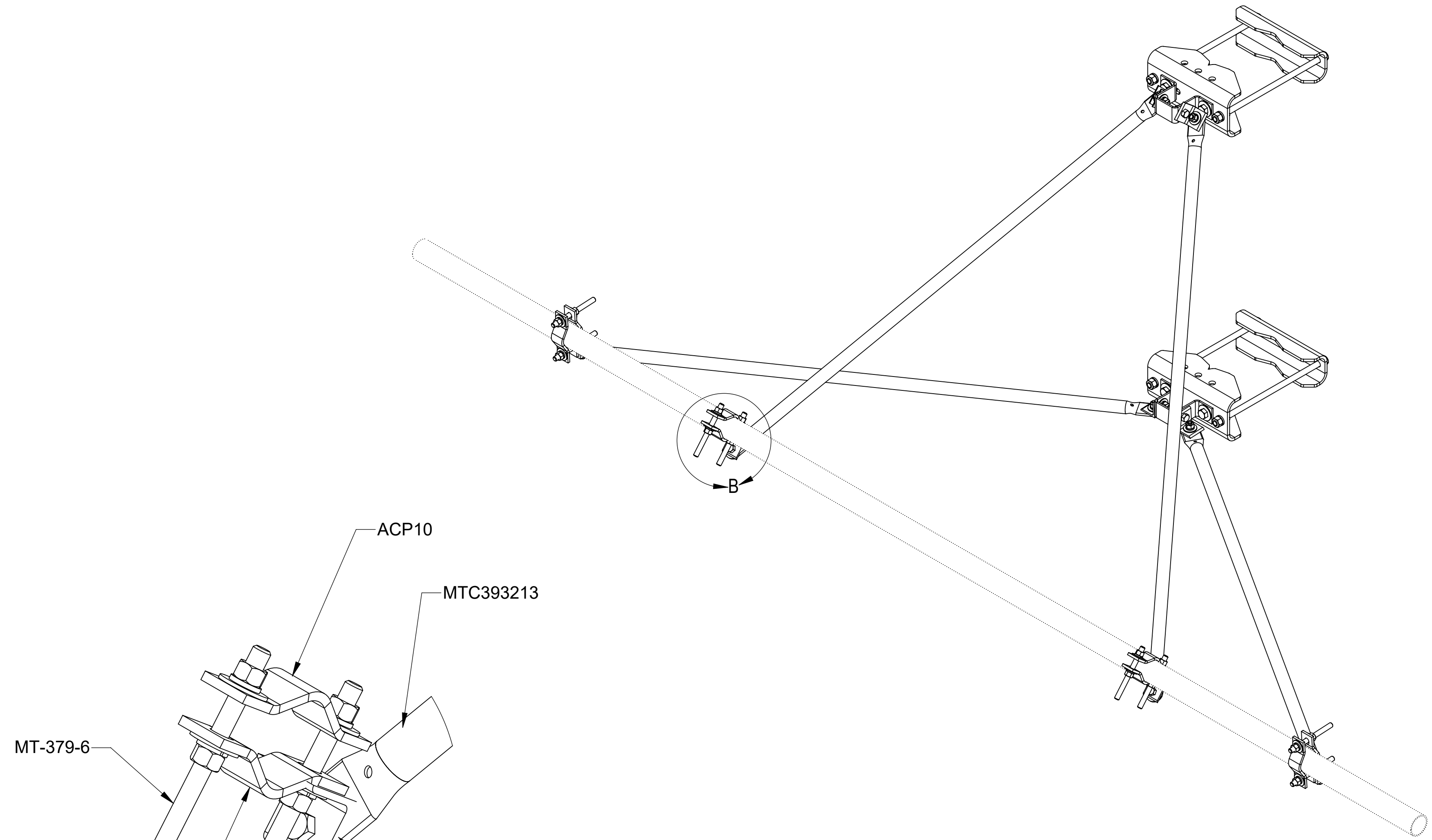
A



**USE OF PIVOT ANGLE REQUIRED FOR OFF APEX AZIMUTH ADJUSTMENT**

|   |                     |                                 |              |               |
|---|---------------------|---------------------------------|--------------|---------------|
| COMMSCOPE, INC. OF NORTH CAROLINA   |                     |                                 |              |               |
| TITLE<br>UNIVERSAL REINFORCEMENT KIT SCTR FRM HD  |                     |                                 |              |               |
| SIZE<br><b>C</b>  | SCALE<br><b>1:8</b> | DOCUMENT NO.<br>VSRDUAL-TS-B-HD |              |               |
|   |                     | DRAWING                         |              | SHEET         |
|   |                     | VERSION<br>00                   | STATUS<br>RE | REVISION<br>B |

© 2021 CommScope, Inc. Confidential

4

3

2

1