

NOTES:

- 1.0 GENERAL NOTES
 - 1.1 ALL METRIC DIMENSIONS ARE IN BRACKETS.
- 2.0 DESIGN NOTES
 - 2.1 FOR PATENT INFORMATION: [HTTPS://WWW.CS-PAT.COM](https://www.cs-pat.com)
 - 2.2 USE STANDARD TORQUE VALUES FOR 5/8" BOLTS
 - 2.3 TORQUE U-BOLTS TO 44 FT-LBS
- 3.0 MANUFACTURING/SPECIAL REQUIREMENTS
- 4.0 TEST
- 5.0 PACKAGING
 - 5.1 PACKAGING SHALL MEET COMMSCOPE REQUIREMENTS PER DOCUMENT IS-PL-3005

REVISIONS				
REV.	IPS	DESCRIPTION	BY	DATE
A	10539PC	NEW RELEASED.	XZ1054	3/11/2021

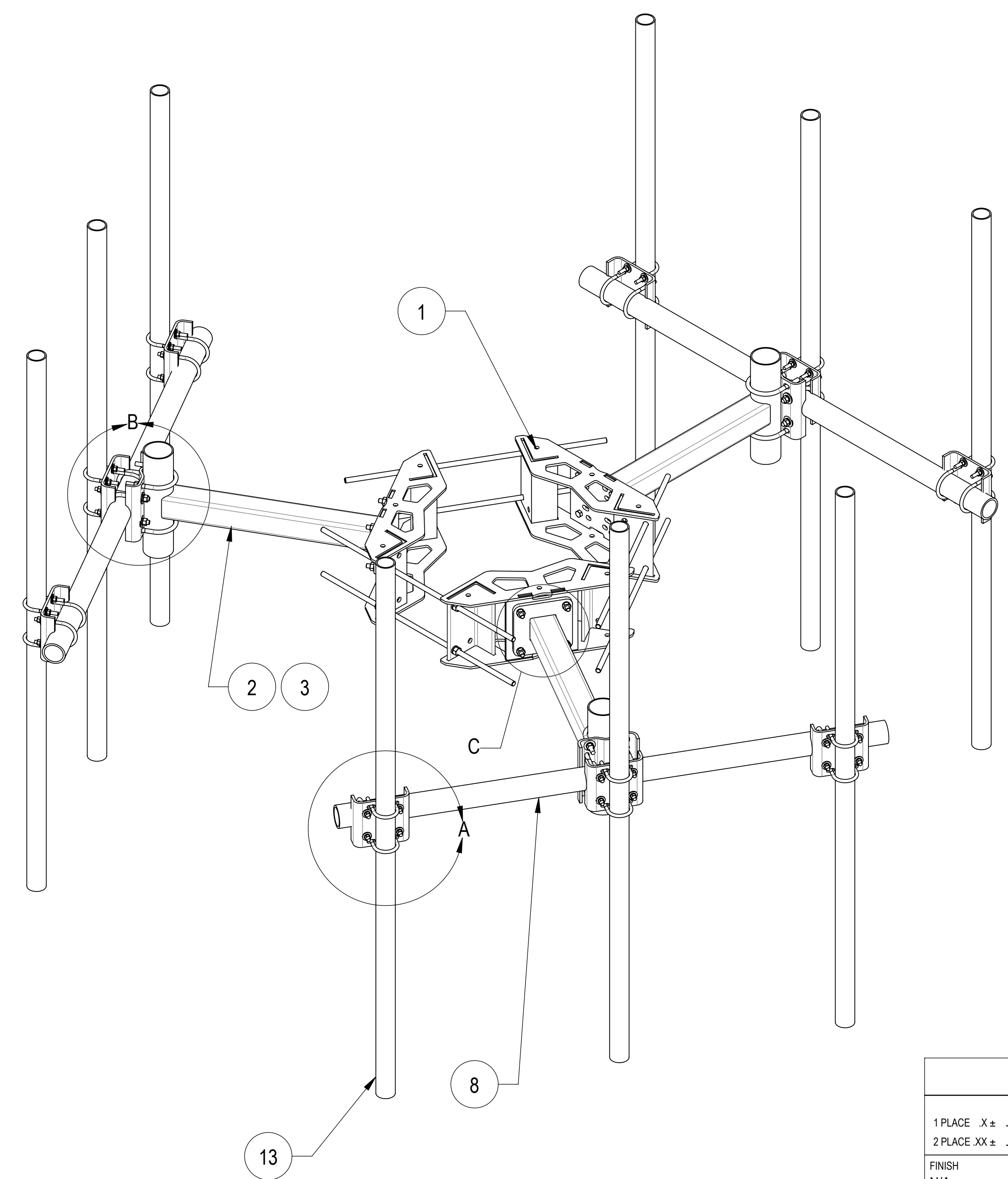
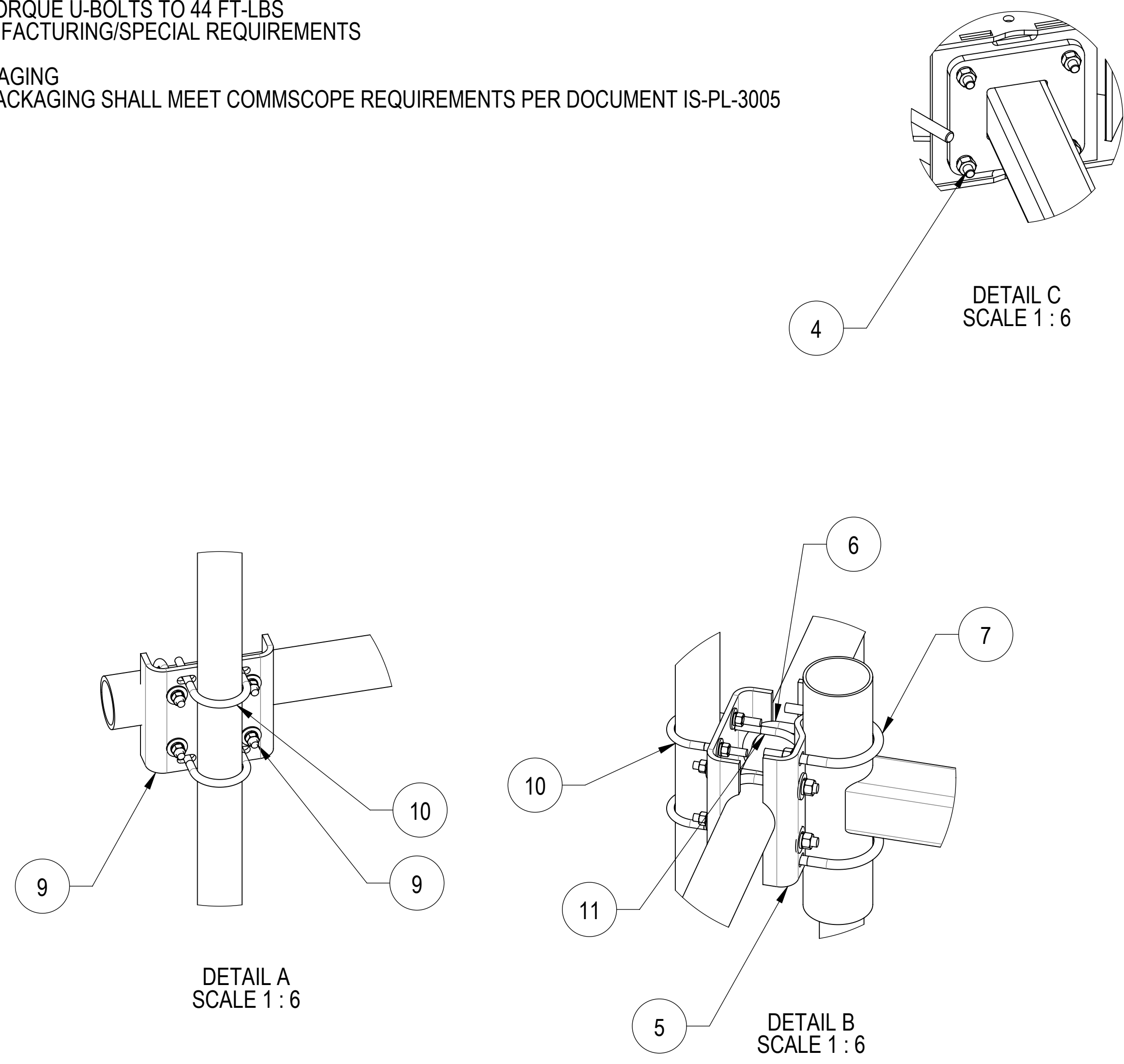

ITEM NO.	PART NUMBER	DESCRIPTION	QTY.
1	MC-RM1550-3	12" - 50" OD RINGMOUNT	1
2	MT197.01	36" SINGLE SUPPORT ARM	3
3	MT197H	HARDWARE KIT (NEXT ITEM)	3
4	GB-0524A	5/8" X 2-1/2" GALV BOLT KIT (A325)	12
5	MT216.13	CENTER BRACKET	3
6	GUB-53560	5/8" X 3-5/8" X 6" GALV U-BOLT	6
7	GUB-5456	5/8" X 4-5/8" X 6 1/2" GALV U-BOLT	6
8	MTC333912	84" X 3-1/2" OD PIPE	3
9	MT219H3501	3.5"OD Clamp Bracket	9
10	GUB-4352	1/2" X 3" X 5-1/4" GALV U-BOLT	18
11	GUB-4356	1/2" X 3-5/8" X 6" GALV U-BOLT	18
13	MT54696	Ø 2.875" O.D. X 96 PIPE	9

COMMSCOPE, INC. OF NORTH CAROLINA

SAP MATERIAL MASTER
MC-K6MHDx-9-96

FINISH: N/A **MATERIAL:** A36, A53

UNLESS OTHERWISE SPECIFIED DIMENSIONS ARE IN INCHES REFER TO PARITY 14.38-199	NAME	DATE	TITLE
CE	XZ1054	03/08/2021	T-ARM, MCK6, 3, 4" x 84" , 9, 2-7/8"x96
RW	ROGHANSON	03/16/2021	
AD	BCAMPBELLCON	03/19/2021	
RE	BCROSS	03/24/2021	
ECN	10539PC		

SCALE: 1:32 **DOCUMENT NO.:** MC-K6MHDx-9-96

SIZE	Auth Group	INSL	MODEL	REVISION	VERSION	STATUS	REVISION	VERSION	STATUS	REVISION	SHEET
D				RE	00	RE	A	00	RE	A	1 OF 2

DENSITY	0.28	lbs/in ³
MASS	1203.02	lbs
VOLUME	4265.23	in ³
SURFACE AREA	35860.22	in ²
HEIGHT	96"	
LENGTH	131.5"	
WIDTH	151.9"	

4

3

2

1

NOTES:

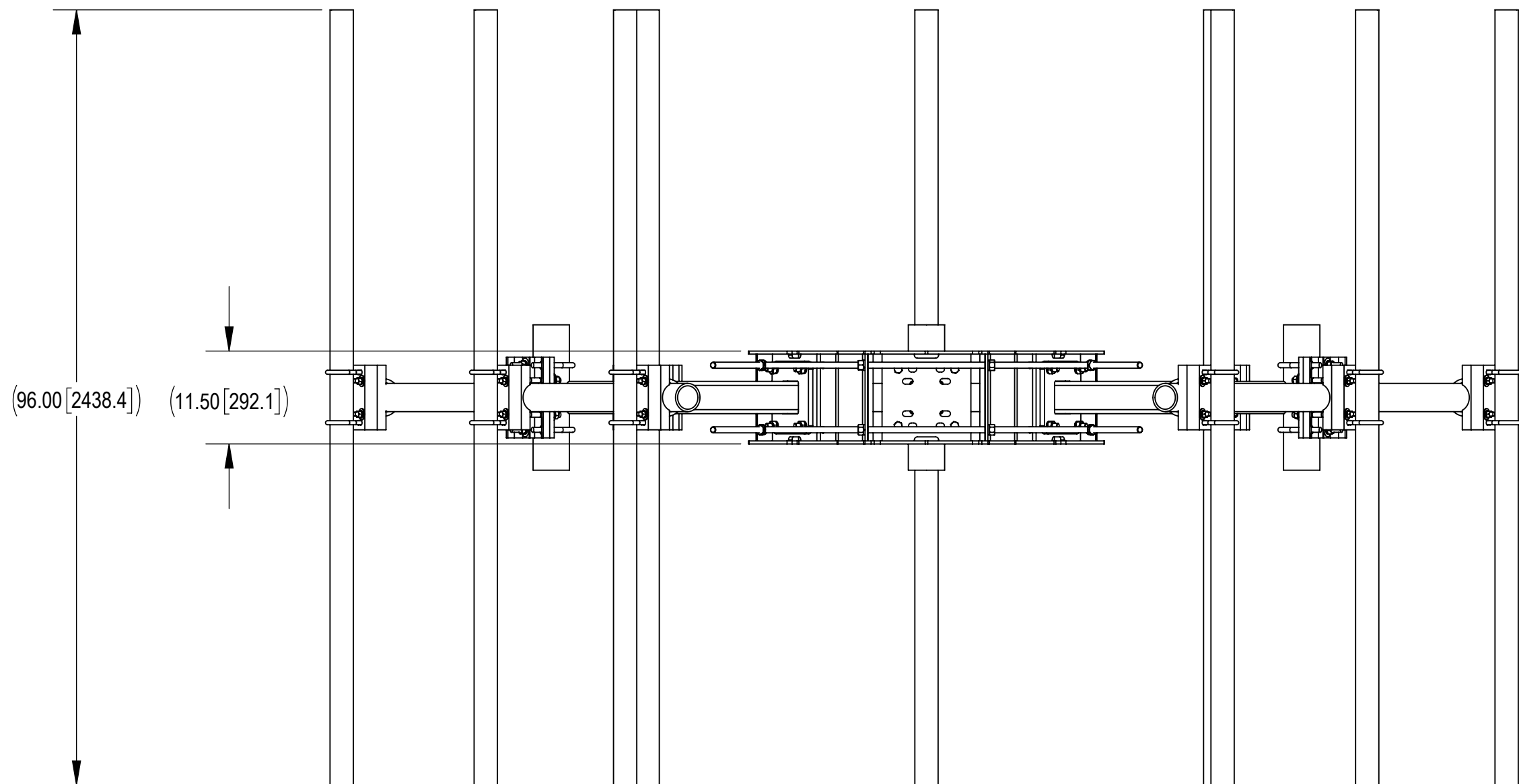
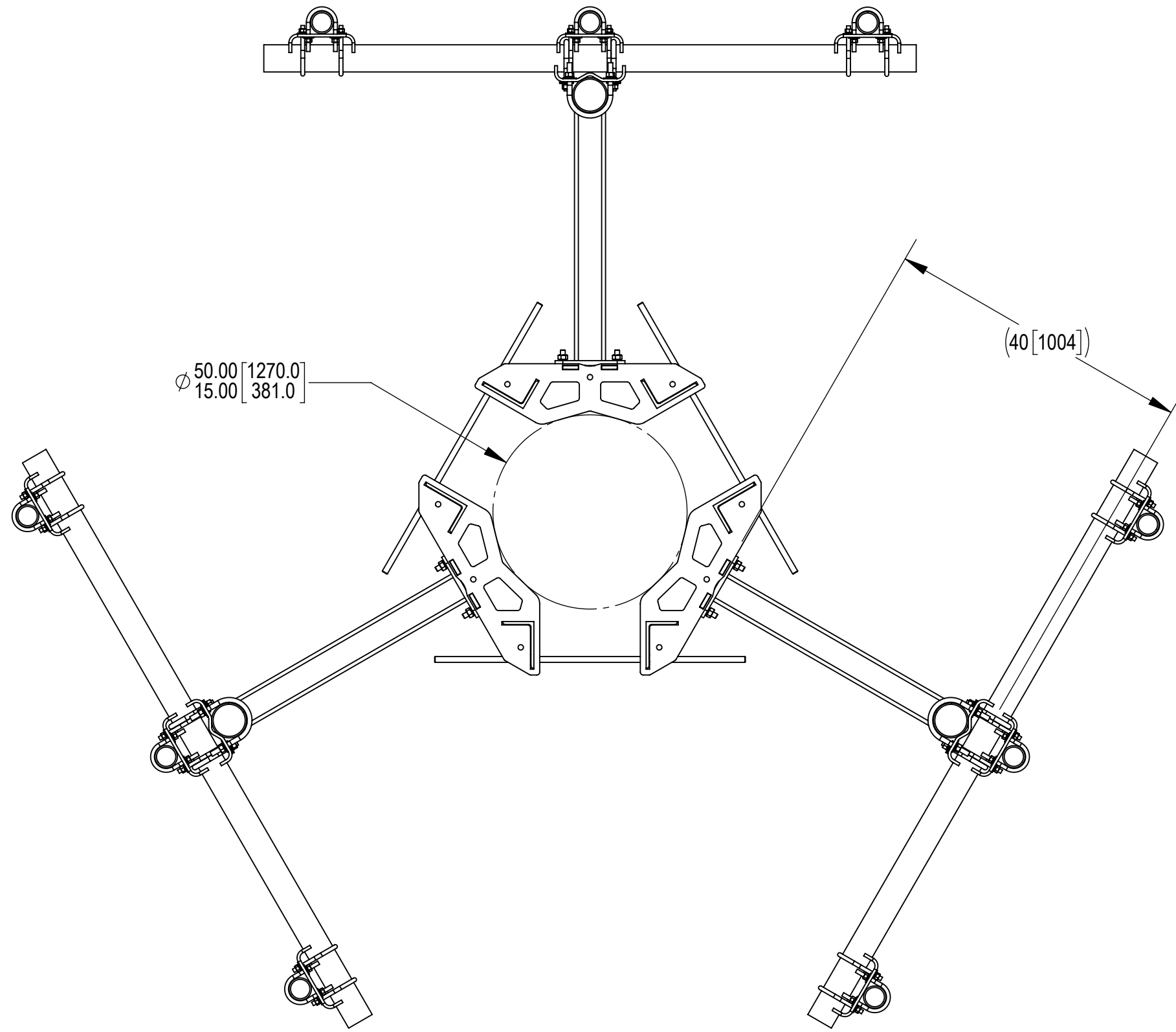

4

3

2

1

COMMSCOPE, INC. OF NORTH CAROLINA				
TITLE T-ARM, MCK6, 3, 4" x 84" , 9, 2-7/8"x96				
SIZE C	SCALE 1:32	DOCUMENT NO. MC-K6MHDX-9-96		
		DRAWING		SHEET
		VERSION	STATUS	REVISION
		00	RE	A
				2 OF 2

© 2021 CommScope, Inc. Confidential

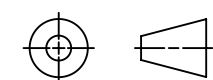

D

C

B

A