

Performance Specification

FOSC - Modular Splice Closure



Date	Edition	Status	Prepared by	Reviewed by	Approved by
5 Oct 2021	A	Active	Mohamed Aznag	Daniel Daems	

Performance Specification for the FOSC Modular Splice Closure

Content	1
1 Scope	2
2 Product description	3
3 Requirements	4
3.1 General requirements	4
3.2 Test sample preparation	5
3.3 Material requirements	7
3.4 Storage and transportation requirements	8
3.5 Sealing performance pass/fail criteria	8
3.6 Sealing performance requirements	9
3.6 Sealing performance requirements (continued)	10
3.6 Sealing performance requirements (continued)	11
3.6 Sealing performance requirements (continued)	12
3.7 Optical pass/fail criteria	13
3.8 Optical performance requirements	14
3.8 Optical performance requirements (continued)	15
4 Quality assurance provisions	16
4.1 Manufacturing follow-up	16
4.2 Responsibility for quality	16
4.3 Qualification conformance	16
4.4 Manufacturing follow-up	16
5 References	17

1 Scope

The FOSC Modular Splice Closure is a combination of a fiber management system and a protective housing designed to provide environmental and mechanical protection for splices and connections between fiber optic cables in the outside plant.

The product is designed to operate in outdoor aerial, handhole and direct buried up to 5 meter depth environments as described in the following standards:

- ETSI EN 300 019-2-4 T4.1 Stationary use at non-weather protected locations
- ETSI EN 300 019-2-8 Stationary use at underground locations
- IEC 61753-1 Ed2 (2018) Categories A, G and S

The described tests and severities in this document are selected to meet the requirements of the following performance standards:

- IEC 61753-111-07 (2021) Sealed closures for category A – Aerial
- IEC 61753-111-08 (2021) Sealed closures for category G – Ground
- IEC 61753-111-09 (2021) Sealed closures for category S – Subterranean
- EN 50411-2-4 (2021) Sealed dome fibre splice closures for category S and A
- ITU-T L.201 (2021) Performance requirements for passive optical nodes: Sealed closures for outdoor environments

The test methods conform international standards of the IEC 61300 series.

Quality assurance provisions and a list of norms complete the document.

The document is intended for use:

- by Commscope Connectivity for internal qualification and re-qualification purposes
- by other organizations to:
 - provide information on product performance
 - act as a guide for test programs
 - analyze and compare product performance in, for example, tender situations
- by Commscope Connectivity customers worldwide, except in countries where a customized document has been prepared.

2 Product description

The FOSC-Modular Splice Closures are designed to operate in categories A (Aerial), G (Ground) and S (Subteranean) as characterized by IEC 61753-1 Ed2 (2018).

Following operating conditions are allowed:

Operational temperature range: -40°C to +65°C

Operational humidity range: 0%RH to 100%RH

Continuous immersion till 5 meters of water head (IP68 according to IEC 60529)



3 Requirements

3.1 General requirements

The FOSC-Modular Splice Closure shall be capable of meeting the functional requirements as specified in the following clauses when the product is installed in accordance with the applicable installation instructions and tested according to the methods of test described in this document.

The components of the kits shall be free of defects that would adversely affect product performance.

The polymeric materials of the closure shall be fungi resistant.

The effect of UV on the outer polymeric materials shall not adversely affect product performance or cause a clear colour change.

Metal parts of the closure shall be resistant to the corrosive influences they may encounter in normal use. A color change due to passivation is allowed.

All fiber cable elements shall be capable of being routed in such a way that no transmission degradation will be seen when accessing these cable elements.

The bend radius of the fibers after installation shall be according to the minimum bend radius specified in IEC 61756-1 Ed2 for high reliability networks (failure probability target $< 10^{-7}$ and macrobend loss of ITU-T G.652.D fibers < 0.05 dB at 1625 nm. The nominal bend radius of the fibers after installation shall be 30 mm throughout the whole closure system. A minimum bend radius of 20 mm is allowed when the stored fiber length per incoming fiber is less than 2 meter (e.g. in the high density or mass splice tray).

The FOSC-Modular Splice Closure shall allow easy fiber access and addition of fiber management modules during installation or maintenance,

The splice trays shall be able to accommodate sufficient fiber on either side of stored splices to allow 10 re-splices.

Access compartments shall have no sharp edges that could damage installers or cables. All device materials that are likely to come into contact with personnel shall be non-toxic and shall not be a potential environmental hazard. All materials shall be RoHS and REACH compliant.

The closures shall be installable at temperatures between -5°C and $+45^{\circ}\text{C}$.

The closure shall be handled at temperatures between -15°C and $+45^{\circ}\text{C}$.

By meeting the requirements in this document the installed closure will automatically meet the IP 68 protection rating according to IEC 60529 (1989/AMD2:2013):

- IP 6X: Fully protected against dust
- IP X8: Continuous immersion in water

Closures shall withstand an impact with energy 20 J over the temperature range -15°C to $+45^{\circ}\text{C}$.

Note: IEC 61753-1 Ed2 and the IEC 61753-111-series do not refer to the IEC 62262 (2002) IK10 test method for fiber optic protective housings. The more severe test method IEC 61300-2-12: 2009 Method B is used.

The products and packaging shall be constructed in such a way that the packaged product shall meet the transportation and storage performance requirements for temperature and humidity in ETSI EN 300 019-2-2 class T2.3 (Public transportation) and ETSI EN 300 019-2-1 class 1.2 (Weather protected, not temperature-controlled storage locations).

Each kit shall have a label with the following information:

- Supplier's name
- Product designation
- Batch number

3.2 Test sample preparation

All installations shall be performed according to CommScope standard installation instructions and carried out at IEC 61300-1 standard laboratory conditions of $+23^{\circ}\text{C} \pm 5^{\circ}\text{C}$.

Sealing test sample preparation:

For each sealing test at least 3 test samples shall be used. All test samples shall be installed with cables. The length of the cables extending the closure shall be long enough to perform the tests (typical cable length is 1 m). The free ends of the cables shall be sealed with a cap. Test samples shall include both maximum and minimum cable diameters as specified in the applicable installation instructions. It is not necessary to use all cable ports. If relevant, open (non-used) cable ports shall be sealed with a plug.

All sealing performance test samples shall be provided with an air pressure test access valve.

When a test is specified at another ambient temperature, samples shall be preconditioned with the correct test pressure for a period of at least 4 hours at that temperature.

Internal pressurization is achieved with an air supply within ± 2 kPa of the specified overpressure value. The pressure and temperature shall be recorded prior the test. Pressure measurements before and after the test shall be carried out with the same pressure measurement equipment and at the same atmospheric conditions (temperature and pressure). When a difference is observed in atmospheric conditions after the test the pressure shall be calculated according to the relationship: $p.V/T=\text{cte}$.

Optical test sample preparation:

Due to the complexity of optical test sample, a minimum of 1 sample shall be used per test. The various tests can be performed sequentially on the same test sample. There is no mandatory sequence defined, but the sequence shall be reported in the test report.

Fiber type in the cables used for the test samples is ITU-T G.652.D or ITU-T G.657.A1 single-mode fiber with nominal mode field diameter between $9.0\ \mu\text{m}$ and $9.2\ \mu\text{m}$ as listed in the table below. By passing the optical performance tests in section 3.7 the product will be automatically qualified for use with the other fiber types ITU-T G.657.A1, A2 and B3 by similarity.

Fiber characteristics used for optical test sample	
Fiber type:	ITU-T G.652.D or IEC 60793-2-50 B-652.D ITU-T G.657.A1 or IEC 60793-2-50 B-657.A1
Proof stress strain test:	$\geq 1\ \%$
Mode field diameter at 1310 nm:	Nominal value between $9.0\ \mu\text{m}$ and $9.2\ \mu\text{m}$ Tolerance $\pm 0.4\ \mu\text{m}$
Cabled fiber cut off wavelength:	$\leq 1260\ \text{nm}$
Cladding diameter:	$125.0\ \mu\text{m} \pm 1.0\ \mu\text{m}$
Non colored coating diameter:	$245\ \mu\text{m} \pm 10\ \mu\text{m}$
Colored coating diameter	$250\ \mu\text{m} \pm 15\ \mu\text{m}$

The selected cables shall be suitable for the specified operating temperature range. Both extremities of a looped feeder cable with loose tubes are terminated in a track/spur joint closure that will hold the cable jacket and central strength member in place (see Figure 1). The length of the looped feeder cable has to be longer than the "dead zone" of the OTDR. Typically, a cable length of 25 m is used to reproduce the cable jacket shrinkage effect as it might occur in reality and also allowing location of the potential causes of optical losses and distinguish whether a change in signal is induced by the fiber management system in a single location or is distributed evenly over the whole circuit length.

In case connectors are used in the optical test sample, the connectors and adapters shall meet the requirements of RUD 5416.

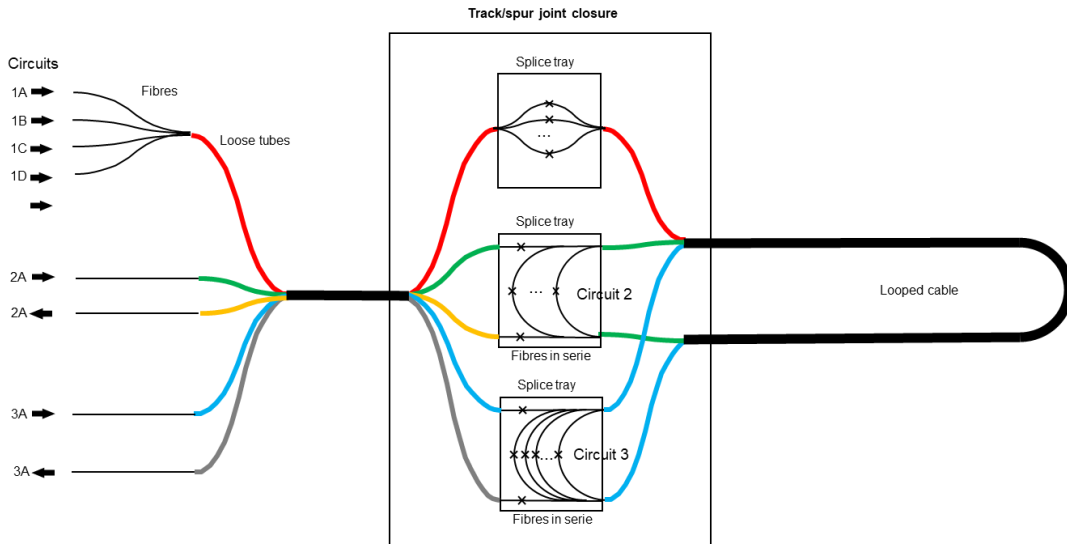

Figure 1 –Preparation optical test sample

Before installing the distribution closure the circuit 3 shall be connected to the transient loss measurement equipment to monitor the change in attenuation during and after the installation of the distriction closure (see installation test in section 3.8).

In the middle of the looped feeder cable with loose tubes, the cable jacket will be removed (= window cut) over a distance according to the installation instructions and the looped feeder cable will be installed in the distribution closure (see Figure 2).

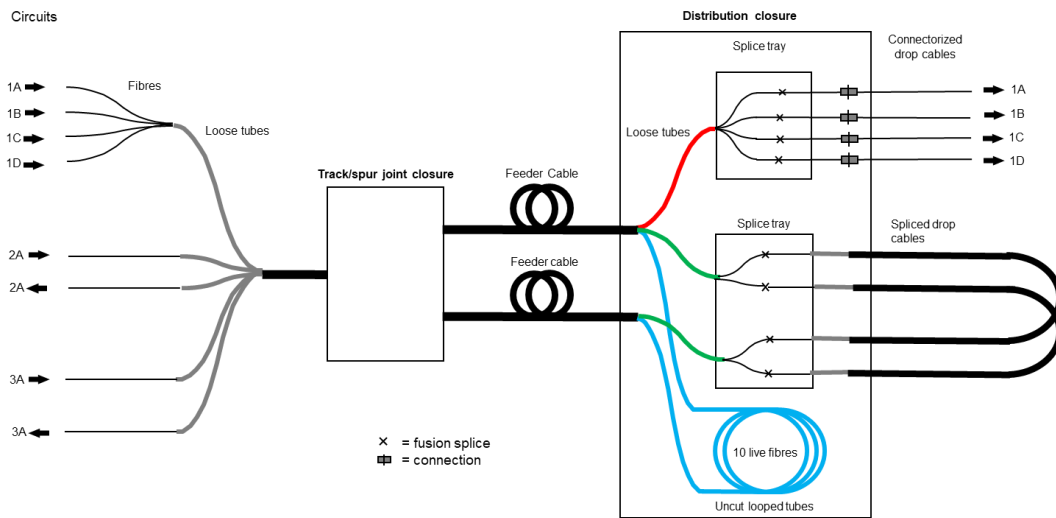

Figure 2 – Test sample configuration

Three (3) circuit types are built as shown in Figure 2.

- Type 1: Point-to-point connections (with connectors)
- Type 2: Point-to-point drop cables (fusion splices)
- Type 3: Looped uncut fibers or tubes (window cut)

For circuits 2 and 3 in the track/spur joint closure the fibers from one feeder cable end are spliced to the fibers of the other feeder cable end in such a way that light will sequentially flow through an optical circuit of random selected fibers from the same loose tube in the looped feeder cable.

In the distribution closure the loose tubes of the circuits 1 and 2 are cut and routed to the splice trays.

The remaining non-active uncut loose tubes are stored inside closure (in the loose tube storage area). For circuit 2, the ends of the looped drop cables with a length of at least 12 m shall be spliced to the relevant fibers of the feeder cables. Space shall be provide for a non-active looped drop cable that will be added during the intervention/reconfiguration test (procedure listed in the table of functional optical requirements, mechanical tests, reconfiguration).

3.3 Material requirements¹

Test	Method and conditions	Acceptance criteria to be checked
Material tests		
UV resistance of outer polymeric materials ISO 4892-3 or ASTM G.154	UV source: Lamp type 1A Fluorescent lamps (UVA 340 nm) Exposure cycles: Cycle 1: Alternating UV and condensation cycle - UV-light: 8 h at (+60 ± 3)°C, with UV light - Condensation: 4 h at (+50 ± 3)°C; dark Exposure time: At least 2160 h Material tests are done on molded dumbbells	Visual examination The average change in mechanical properties (tensile strength at yield and elongation at yield) shall be less than 20%.
Fungus resistance (Mould growth) ISO 846 or IEC 60068-2-10 or ASTM G.21	Strains: 2 mixed spore suspensions according to ISO846 and ASTM G21 Inoculation conditions: Test severity 1 Temperature: (29 ± 1)°C Relative humidity: > 90% Duration: 28 days Material tests are done on molded dumbbells	Visual examination: When a rating 0 is obtained, the material is considered fungus resistant and no further testing is required. When a rating of 1 or 2 is obtained, the effect of mould growth shall be evaluated by measuring a representative performance property (e.g. tensile strength at yield and elongation at yield for thermoplastic polymers, a compression set, a Shore A hardness for elastic materials, or any other test which checks a relevant property) both before and after exposure of the material samples. The average change in mechanical characteristics of the tested material samples shall be less than 20 %. A rating of more than 2 is not allowed.

¹ Material tests are done on molded dumbbells

3.4 Storage and transportation requirements ²

Test	Method and conditions		Acceptance criteria to be checked
Environmental storage and transport tests of packaged products			
Cold IEC 61300-2-17	Temperature: Duration:	$(-40 \pm 2)^{\circ}\text{C}$ 96 h	Visual examination No defects which would adversely affect the installation or affect product performance and functionality after installation
Dry heat IEC 61300-2-18	Temperature: Humidity Duration:	$(+70 \pm 2)^{\circ}\text{C}$ Uncontrolled 96 h	Visual examination No defects which would adversely affect the installation or affect product performance and functionality after installation
Damp heat (steady state) IEC 61300-2-19	Temperature: Humidity Duration:	$(+40 \pm 2)^{\circ}\text{C}$ $(93 \pm 3)\%RH$ 96 h	Visual examination No defects which would adversely affect the installation or affect product performance and functionality after installation

3.5 Sealing performance pass/fail criteria

Performance criteria	Method and conditions		Requirements
Sealing performance pass/fail criteria			
Pressure loss during test IEC 61300-2-38 Method B	Internal pressure: Temperature: Elapsed time:	(40 ± 2) kPa At specified test temperature < 12 h between initial and final measurement	Difference in pressure before & after the test ≤ 2 kPa measured at the same atmospheric conditions
Sealing after test IEC 61300-2-38 Method A	Internal pressure: Test temperature: Test time: Depth: Pre-conditioning procedure:	(40 ± 2) kPa $(23 \pm 5)^{\circ}\text{C}$ 15 minutes Just below water surface Sample shall be conditioned to room temperature for at least 4 h if it was tested at a different test temperature	No continuous emission of bubbles
Visual examination IEC 61300-3-1	Examination of product with naked eye.	Inspection with the naked eye for displacements, flaws, defects, cracks or impurities that could impair functionality.	No defects which would adversely affect product performance

² Storage and transportation tests are performed on non-installed products (as they are appearing in the package)

3.6 Sealing performance requirements

Test	Method and conditions	Acceptance criteria from clause 3.5 to be checked
Sealing performance tests		
Assembly / disassembly for categories A and G IEC 61300-2-33	Number of re-entries: 5 Aging cycle between each re-entry: minimum 1 temperature cycle Temperature range: -40°C/+65°C - Dwell time: 4 h - Transition: 1 °C/min Test pressure: (20 ± 2) kPa overpressure regulated	Visual examination Sealing performance after closing the closure.
Assembly / disassembly for category S IEC 61300-2-33	Number of re-entries: 5 Aging cycle between each re-entry: minimum 1 temperature cycle Temperature range: -30°C/+60°C - Dwell time: 4 h - Transition: 1 °C/min Test pressure: (40 ± 2) kPa overpressure regulated	Visual examination Sealing performance after closing the closure.
Cable retention IEC 61300-2-4	Test temperatures: (-15 ± 2)°C and (+45 ± 2)°C Test pressure: (40 ± 2) kPa overpressure sealed off at test temperature Force per cable: 20 (N/mm) × Ø _{cable} (mm) for terminations with CTU types S, L or G 10 (N/mm) × Ø _{cable} (mm) for other cable terminations with metal bracket For non-circular cables, Ø _{cable} = circumference/pi Point of load application ³ : The distance measured from the cable port or seal of the closure to the point of the load application shall be 400 mm Rate: 0 to full load in 15 s, smoothly applied Duration: 1 h per cable and per test temperature	Visual examination Sealing performance (pressure loss) during test Sealing performance after completion of test

³ If an external cable attachment bracket is an integrated part of the protective housing, the distance of application is measured from end of bracket.

3.6 Sealing performance requirements (continued)

Test	Method and conditions	Acceptance criteria from clause 3.5 to be checked	
Sealing performance tests (continued)			
Cable axial compression IEC 61300-2-11	Test temperature:	(+23 ± 5)°C	Visual examination
	Test pressure:	Not applicable	
	Force per cable:	10 N for $\varnothing_{\text{Cable}} < 3\text{mm}$ 20 N for $3\text{ mm} \leq \varnothing_{\text{Cable}} < 6\text{ mm}$ 50 N for $6\text{ mm} \leq \varnothing_{\text{Cable}} < 10\text{ mm}$ 100 N for $10\text{ mm} \leq \varnothing_{\text{Cable}} < 20\text{ mm}$ 200 N for $\varnothing_{\text{Cable}} \geq 20\text{ mm}$ 10 N for tubes and cables without any strength member attachment For non-circular cables $\varnothing_{\text{cable}} = \text{circumference}/\pi$	
	Load application:	The distance measured from the cable port or seal of the closure to the point of the load application shall be at maximum two times the cable diameter to prevent cable buckling	
	Rate:	0 to full load in 15 s, smoothly applied	
	Duration:	30 minutes per cable	
Cable bending IEC 61300-2-37	Test temperatures:	(-15 ± 2)°C and (+45 ± 2)°C	Visual examination Pressure loss during test Sealing performance after completion of test
	Test pressure:	(40 ± 2) kPa overpressure sealed off at test temperature	
	Bending angle:	At least -30° and +30°	
	Duration at each extreme position:	5 minutes	
	Point of application ² :	400 mm from end of seal	
	Number of cycles:	5 cycles per cable and per test temperature	
Cable torsion IEC 61300-2-5	Test temperature:	(-15 ± 2)°C and (+45 ± 2)°C	Visual examination Pressure loss during test Sealing performance after completion of test
	Test pressure:	(40 ± 2) kPa overpressure sealed off at test temperature	
	Torsion angle:	At least - 90° and +90°	
	Point of application ⁴ :	400mm from end of cable seal sleeve	
	Duration at each extreme position:	5 minutes	
	Tensile load:	None	
	Number of cycles:	5 per cable and per test temperature	

⁴ If an external cable attachment bracket is an integrated part of the protective housing, the distance of application is measured from end of bracket.

3.6 Sealing performance requirements (continued)

Test	Method and conditions		Acceptance criteria from clause 3.5 to be checked	
Sealing performance tests (continued)				
Impact IEC 61300-2-12 Method B	Test temperatures:	$(-15 \pm 2)^{\circ}\text{C}$ and $(+45 \pm 2)^{\circ}\text{C}$	Visual examination Pressure loss during test Sealing performance after completion of test	
	Test pressure:	(40 ± 2) kPa overpressure sealed off at test temperature		
	Impact tool:	Steel ball		
	Weight:	1 kg		
	Drop height:	2 m		
	Location:	Center of closure at 0° , 90° , 180° , 270° rotation along longitudinal axe		
Number of impacts:	1 per location and per test temperature			
Crush resistance (Static load) IEC 61300-2-10	Test temperature:	$(-15 \pm 2)^{\circ}\text{C}$ and $(+45 \pm 2)^{\circ}\text{C}$	Visual examination Pressure loss during test Sealing performance after completion of test	
	Test pressure:	(40 ± 2) kPa overpressure sealed off at test temperature		
	Load:	1000 N		
	Surface:	25 cm ² (circular shape)		
	Location:	Center of closure at 0° and 90° rotation along longitudinal axe		
Duration:	10 minutes per location and per test temperature			
Vibration IEC 61300-2-1	Test temperature:	$(+23 \pm 5)^{\circ}\text{C}$	Visual examination Sealing performance after completion of test	
	Test pressure:	(40 ± 2) kPa overpressure regulated		
	Frequency:	(10 ± 1) Hz		
	Cycle:	Sinusoidal		
	Amplitude:	3 mm		
	Cable clamping:	500 mm from end of cable seal sleeve		
Duration:	1 000 000 cycles (about 28 h)			
Resistance to aggressive media IEC 61300-2-34	Test temperature	$(+23 \pm 5)^{\circ}\text{C}$	Visual examination. . No swelling, cracking or permanent deformation allowed. Sealing performance after completion of test	
	Test pressure:	(40 ± 2) kPa overpressure regulated		
	Media / test time:	- pH2 (HCl) for 5 days, no drying time - pH12 (NaOH) for 5 days, no drying time - Petroleum jelly for 5 days, no drying time - Diesel fuel for 1 h immersion and 24 h drying time at room temperature		
	Duration:	5 days		
	Drying time at 70°C	None		
Resistance to stress cracking IEC 61300-2-34	Test temperature:	$(+50 \pm 2)^{\circ}\text{C}$	Visual examination. No visible cracking Sealing performance after completion of test	
	Test pressure:	(40 ± 2) kPa overpressure regulated		
	Medium:	10% Nonyl Phenol Ethoxylate solution (Igepal)		
	Duration:	5 days		
	Drying time at 70°C	None		

3.6 Sealing performance requirements (continued)

Test	Method and conditions	Acceptance criteria from clause 3.5 to be checked	
Sealing performance tests (continued)			
Salt mist IEC 61300-2-26	Test temperature:	(+35 ± 2)°C	Visual examination. No signs of corrosion, A color change due to passivation is allowed. Sealing performance after completion of test
	Test pressure:	0 kPa overpressure sealed off at room temperature	
	Medium:	5% NaCl in water (pH 6,5-7,2)	
	Duration:	5 days	
	Test sample:	Installed and closed enclosure	
Change of temperature for categories A and G IEC 61300-2-22	Lowest temperature:	(-40 ± 2)°C	Visual examination Sealing performance after completion of test
	Highest temperature:	(+65 ± 2)°C	
	Dwell time:	4 h	
	Transition :	1 °C/min	
	Internal pressure:	(20 ± 2) kPa overpressure regulated	
	Number of cycles:	12	
Change of temperature for category S IEC 61300-2-22	Lowest temperature:	(-30 ± 2)°C	Visual examination Sealing performance after completion of test
	Highest temperature:	(+60 ± 2)°C	
	Dwell time:	4 h	
	Transition :	1 °C/min	
	Internal pressure:	(40 ± 2) kPa overpressure regulated	
	Number of cycles:	12	
Change of temperature in water (no international standard)	Lowest temperature:	(+10 ± 2)°C	Visual examination. No signs of water ingress.
	Highest temperature:	(+55 ± 2)°C	
	Dwell time:	4 h	
	Transition :	0.5 °C/min	
	Internal pressure:	No overpressure, sealed off at room temperature	
	Immersion depth:	Just below water surface	
	Number of cycles:	12	
Water immersion IEC 61300-2-23	Test temperature:	(+23 ± 5)°C	Visual examination. No signs of water ingress.
	Column height:	5 m water	
	Test pressure:	No overpressure, sealed off at test temperature	
	Duration:	7 days	
	Wetting agent:	None	

3.7 Optical pass/fail criteria

Test method	Test conditions		Requirements
Optical pass/fail criteria tests			
Change in attenuation IEC 61300-3-3	Source wavelength:	1310 nm , 1550 nm and 1625 nm	For incoming fiber with ITU-T G.652.D fibers: $\delta \leq 0.2$ dB during test at 1310 nm and 1550 nm and $\delta \leq 0.5$ dB during test at 1625 nm $\delta \leq 0.1$ dB at 1310 nm, 1550 nm and 1625 nm after test. For incoming fiber with ITU-T G.657.A1 fibers: $\delta \leq 0.2$ dB during test at 1310 nm, 1550 nm and 1625 nm $\delta \leq 0.1$ dB at 1310 nm, 1550 nm and 1625 nm after test (=residual loss)
Transient loss IEC 61300-3-28	Source wavelength: Detector bandwidth:	1550 nm and 1625 nm 0-1500 Hz	For incoming fiber with ITU-T G.652.D fibers: $\delta \leq 0.5$ dB during test at 1550 nm $\delta \leq 1.0$ dB during test at 1625 nm $\delta \leq 0.1$ dB at 1310 nm, 1550 nm and 1625 nm after test. For incoming fiber with ITU-T G.657.A1 fibers: $\delta \leq 0.5$ dB during test at 1550 nm and 1625 nm $\delta \leq 0.1$ dB at 1550 nm and 1625 nm after test (=residual loss)
Visual examination IEC 61300-3-1	Examination of product with naked eye.	Inspection with the naked eye for flaws, defects, cracks or impurities that could impair functionality.	No defects which would adversely affect product performance or functionality

Notes

- The change in attenuation δ refers to the +/- deviation from the original value of the transmitted power at the start of the test .
- An "incoming fiber" is defined as a part of an optical circuit containing the fiber entering the product, a connection spliced to a fiber leaving the product. One optical circuit can contain many "incoming fibers". Light will sequentially flow through all the "incoming fibers".

3.8 Optical performance requirements

Test method	Test conditions	Acceptance criteria from clause 3.7 to be checked
Optical performance tests		
Cable retention IEC 61300-2-4	Test temperature: $(+23 \pm 5)^\circ\text{C}$ Force per cable: $20 \text{ (N/mm)} \times \varnothing_{\text{cable}} \text{ (mm)}$ for terminations with CTU types S, L or G $10 \text{ (N/mm)} \times \varnothing_{\text{cable}} \text{ (mm)}$ for other cable terminations with metal bracket For non-circular cables, $\varnothing_{\text{cable}} = \text{circumference}/\pi$ Point of application ⁵ : 400 mm from end of seal measured from cable seal Rate: 0 to full load in 15 s, smoothly applied Duration: 1 h per cable	Visual examination Transient loss
Cable bending IEC 61300-2-37	Test temperature: $(+23 \pm 5)^\circ\text{C}$ Bending angles: From 0° to -30° to 0° to $+30^\circ$ to 0° (= 1 cycle) Duration at each extreme position: 5 minutes at -30° and $+30^\circ$ Point of application ⁴ : 400 mm from end of seal Number of cycles: 5 cycles per cable.	Visual examination Transient loss
Cable torsion IEC 61300-2-5	Test temperature: $(+23 \pm 5)^\circ\text{C}$ Torsion angles: From 0° to -90° to 0° to $+90^\circ$ to 0° (= 1 cycle) Torque application ⁴ : 400 mm from end of seal Duration at each extreme position: 5 minutes at -90° and $+90^\circ$ Tensile load: None	Visual examination Transient loss

⁵ If an external cable attachment bracket is an integrated part of the protective housing, the distance of application is measured from end of bracket.

3.8 Optical performance requirements (continued)

Test method	Test conditions	Pass/fail criteria from clause 3.7 to be checked
Optical performance tests - continued		
Reconfiguration IEC 61300-2-33	Test temperature: $(+23 \pm 5)^{\circ}\text{C}$ Procedure: <ol style="list-style-type: none"> 1. - Moving closure to working location. Handling of cables attached to node. 2. Open closure. 3. Gaining access to previously installed fibers in the fiber management system by hinging the trays in between the extreme positions. 4. Close and secure fiber management system 5. Close closure. 	Transient loss in active circuits in splice trays adjacent to the splice tray with circuits that are reconfigured or added
Vibration IEC 61300-2-1	Test temperature: $(+23 \pm 5)^{\circ}\text{C}$ Sweep range: (5 to 500 to 5) Hz at 1 octave/minute - crossover frequency: 9 Hz - severity below 9 Hz: 3.5 mm - severity above 9 Hz: 10 m/s^2 (about 1 g) Axes: 3 mutually perpendicular Duration: 10 cycles/axis	Visual examination Transient loss
Shock IEC 61300-2-9	Test temperature: $(+23 \pm 5)^{\circ}\text{C}$ Acceleration: 150 m/s^2 (about 15 g) Pulse duration: 11 milliseconds Wave form: half sine Number of shocks: In total 18 shocks. 3 shocks per axis and per direction of the axis.	Visual examination Transient loss
Change of temperature ⁶ IEC 61300-2-22	Lowest temperature: $(-40 \pm 2)^{\circ}\text{C}$ Highest temperature: $(+65 \pm 2)^{\circ}\text{C}$ Dwell time: 4 h Transition time: $1^{\circ}\text{C} / \text{minute}$ Number of cycles: 12 Cycles 1-10: cables out of climatic test chamber, Cycles 11-20: all cables in climatic test chamber	Examination Change in attenuation

⁶ If this temperature falls outside the range specified for any of the cables being used, the test temperature must be modified accordingly.

4 Quality assurance provisions

4.1 Manufacturing follow-up

Quality provisions are based upon the philosophy of TQM (Total Quality Management) with a system approved to ISO 9001.

4.2 Responsibility for quality

Unless otherwise stated in the customer order, it shall be CommScope' responsibility to assure qualification and lot conformance to this specification. CommScope may utilize its own or other testing and inspection facilities acceptable to the customer.

4.3 Qualification conformance

For the purposes of internal qualification, the program shall consist of examinations and tests to determine conformance with the requirements of this specification.

It shall be performed once, on introduction of the product.

Subsequent design changes shall be partially or fully re-qualified depending upon their area of impact in the context of product functionality.

Regular requalification testing shall be performed as defined by the Quality Department.

4.4 Manufacturing follow-up

CommScope products target Six Sigma levels of performance by the integration of capable processes from the development throughout the entire supply chain. The goal is to reduce variability to achieve zero defects for products and services. Systems used are based on preventive and statistical techniques during development and manufacturing.

This also includes suppliers of materials, components or systems. Dedicated procedures for supplier selection, development and follow-up are implemented to ensure conformance to TQM and specification requirements.

Best demonstrated practices are identified and implemented throughout the company, with a continuing challenge to identify opportunities for innovation and improvement.

5 References

Reference *	Title
ASTM G.21 (2015)	Standard Practice for Determining Resistance of Synthetic Polymeric Materials to Fungi
ASTM G.154 (2016)	Standard Practice for Operating Fluorescent Ultraviolet (UV) Lamp Apparatus for Exposure of Nonmetallic Materials
EN 50411-2-4 (2012)	Fibre organisers and closures to be used in optical fibre communication systems - Product specifications - Part 2-4: Sealed dome fibre splice closures Type 1, for category S & A
ETSI EN 300-019-series	Equipment engineering (EE); environmental conditions and environmental tests for telecommunications equipment;
ETSI EN 300-019-2-1 (2014)	Part 2-1: Specification of environmental tests-Storage
ETSI EN 300-019-2-2 (2013)	Part 2-2: Specification of environmental tests-Transportation
ETSI EN 300-019-2-4 (2015)	Part 2-4: Specification of environmental tests; stationary use at non-weather protected locations
ETSI EN 300-019-2-8 (1990)	Part 2-8: Stationary use at underground locations
IEC 60068-2-10 (2005) + AMD1 (2018)	Environmental testing - Part 2-10: Tests - Test J and guidance: Mould growth
IEC 60529 (1989) +AMD1:1999 +AMD2:2013	Degrees of protection provided by enclosures (IP code).
IEC 60793-2-50 (2018)	Optical fibers - Part 2-50: Product specifications - Sectional specification for class B single-mode fibers
IEC 60950-1 (2013)	Information technology equipment - Safety - Part 1: General requirements
IEC 61300-series	Fiber-optic interconnecting devices and passive components.
IEC 61300-1 (2016)	General and guidance
IEC 61300-2-series	Part 2: basic test and measurement procedures:
IEC 61300-2-1 (2009)	Vibration (sinusoidal).
IEC 61300-2-4 (2019) + AMD1 (2019)	Fiber/cable retention.
IEC 61300-2-5 (2009)	Torsion
IEC 61300-2-9 (2010)	Shock.
IEC 61300-2-10 (2021)	Crush and load resistance
IEC 61300-2-11 (2012)	Axial compression
IEC 61300-2-12 (2009)	Impact
IEC 61300-2-22 (2007)	Change of temperature.
IEC 61300-2-23 (2010)	Water Immersion
IEC 61300-2-26 (2006)	Salt mist
IEC 61300-2-33 (2012)	Assembly and disassembly of closures.
IEC 61300-2-34 (2009)	Resistance to Solvents and Contaminating Fluids.
IEC 61300-2-37 (2016)	Cable Bending for Closures.
IEC 61300-2-38 (2006)	Sealing for Pressurized Closures of Fiber Optic Devices
IEC 61300-3-series	Part 3: examination and measurements.
IEC 61300-3-1 (2005)	Visual examination.
IEC 61300-3-3 (2009)	Monitoring change in attenuation and in return loss (multiple paths).
IEC 61300-3-28 (2012)	Transient loss.
IEC 61753-1 (2018) + COR1 (2019)	Fibre optic interconnecting devices and passive components - Performance standard - Part 1: General and guidance
IEC 61753-111-07 (2021)	Fibre optic interconnecting devices and passive components - Performance standard - Part 111-07: Sealed closures - Category A - Aerial

IEC 61753-111-08 (2021)	Fibre optic interconnecting devices and passive components - Performance standard - Part 111-08: Sealed closures for category G - Ground
IEC 61753-111-09 (2021)	Fibre optic interconnecting devices and passive components - Performance standard - Part 111-09: Sealed closures - Category S - Subterranean
IEC 61756-1 (2019)	Fibre optic interconnecting devices and passive components - Interface standard for fibre management systems - Part 1: General and guidance
IEC 62368-1 (2018)	Audio/video, information and communication technology equipment - Part 1: Safety requirements
ISO 846 (2019)	Resistance of Synthetic Polymeric Materials to Fungi and Bacteria.
ISO 4892-3 (2016)	Plastics — Methods of exposure to laboratory light sources — Part 3: Fluorescent UV lamps
ISO 1998/1 (1998)	Petroleum Industry - Vocabulary - Part 1.
ISO 9001	Quality Management Systems - Requirements.
ITU-T G.652 (2013)	Characteristics of single-mode fiber optic cable.
ITU-T.G 657 (2012)	Characteristics of a bending loss insensitive single mode optical fiber and cable for the access network
ITU-T L.201 (2021)	Performance requirements for passive optical nodes: Sealed closures for outdoor environments
RUD 5416	Singlemode Optical Fiber Connectors, Pigtails, Patchcords and Adapters with ITU-T G.657 Fiber

The documents listed here shall form a part of this specification.

The non dated versions, in effect at the date of issue of this specification, shall apply.

Other equivalent national standards may be used as substitutes for international ones.

* Copies of the documents referred to may be obtained from

ASTM	American Society for Testing and Materials	www.astm.org
EN	European Committee for Electrotechnical Standardization	www.cenelec.org
ETS	European Telecommunications Standards Institute	www.etsi.org
IEC	International Electrotechnical Commission	www.iec.ch
ISO	International Standards Organisation	www.iso.ch
ITU	International Telecommunications Union	www.itu.int
UL	Underwriters Laboratories Inc.	www.ul.com



www.CommScope.com
Diestsesteenweg 692
B-3010 Kessel-Lo
Belgium

Visit our website or contact your local CommScope representative for more information.

© 2020 CommScope, Inc. All rights reserved.

All trademarks identified by ® or ™ are registered trademarks or trademarks, respectively, of CommScope, Inc.

OptiTap is a registered trademark of Corning Cable Systems Solutions.

This document is for planning purposes only and is not intended to modify or supplement any specifications or warranties relating to CommScope products or services.