

E11F03P88

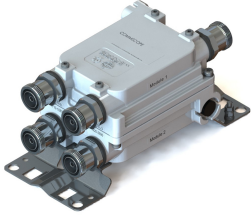

Twin Diplexer, 1800/2100-2600, dc block all ports, with 7/16 DIN connectors

- Designed for network Modernization, introduction of LTE1800 on existing site
- Designed for network modernization application, introduction of LTE2300 and LTE2600 on existing site
- Twin configuration
- dc/AISG blocking on all ports (DC open)

Product Classification

Product Type Diplexer

General Specifications

Color Gray

Modularity 2-Twin

Mounting Pole | Wall

Mounting Pipe Hardware Band clamps (2)

RF Connector Interface 7-16 DIN Female

Dimensions

Height 86 mm | 3.386 in

Width 109 mm | 4.291 in

Depth 139 mm | 5.472 in

Mounting Pipe Diameter Range 43–122 mm

Outline Drawing

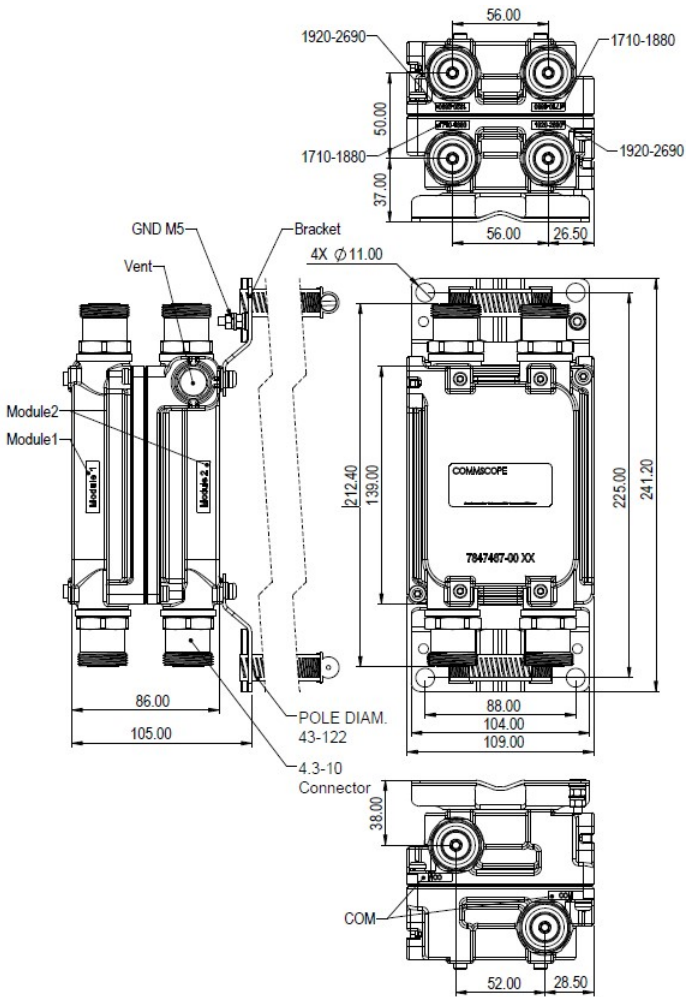

Electrical Specifications

Impedance	50 ohm
License Band, Band Pass	DCS 1800 IMT 2100 IMT 2600 WCS 2300

Electrical Specifications, dc Power/Alarm

dc/AISG Pass-through Method	No dc/AISG pass-through
dc/AISG Pass-through, combiner	dc/AISG blocking on all ports
dc/AISG Pass-through, demultiplexer	dc/AISG blocking on all ports
Lightning Surge Current	10 kA
Lightning Surge Current Waveform	8/20 waveform

Electrical Specifications

E11F03P88

Sub-module	1 2	1 2
Branch	1	2
Port Designation	PORT 1 1710-1880	PORT 2 1920-2690
License Band	DCS 1800, Band Pass	IMT 2100, Band Pass WCS 2300, Band Pass IMT 2600, Band Pass

Electrical Specifications, Band Pass

Frequency Range, MHz	1710–1880	1920–2690
Insertion Loss, typical, dB	0.15	0.15
Return Loss, typical, dB	22	22
Isolation, typical, dB	40	40
Input Power, RMS, maximum, W	250	250
Input Power, PEP, maximum, W	1000	1000
3rd Order PIM, typical, dBc	-157	-157
3rd Order PIM Test Method	Two +43 dBm carriers	Two +43 dBm carriers

Block Diagram

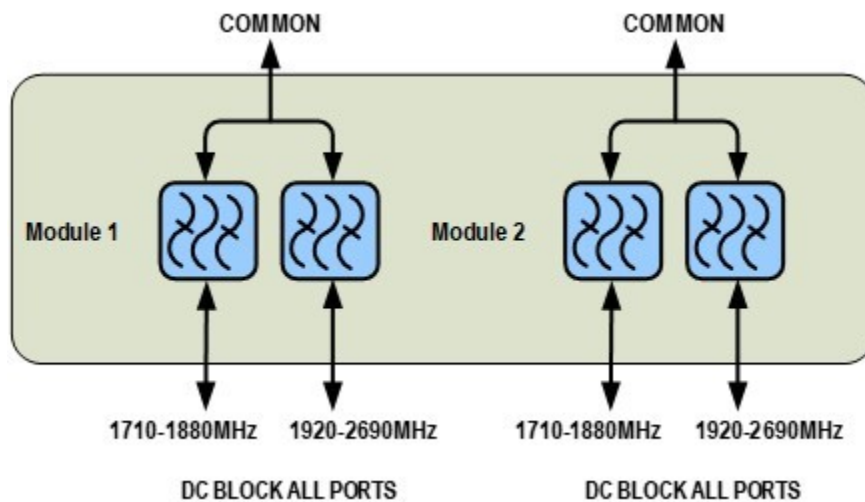

Environmental Specifications

Operating Temperature	-40 °C to +65 °C (-40 °F to +149 °F)
Corrosion Test Method	IEC 60068-2-11, 30 days
Environmental Test Method	ETSI EN 300 019-1-4
Ingress Protection Test Method	IEC 60529:2001, IP67

E11F03P88

Packaging and Weights

Included	Mounting hardware
Volume	1.3 L
Weight, with mounting hardware	2.5 kg 5.512 lb
Weight, without mounting hardware	2.3 kg 5.071 lb

Regulatory Compliance/Certifications

Agency

ISO 9001:2015



Classification

Designed, manufactured and/or distributed under this quality management system