

E15S02P87

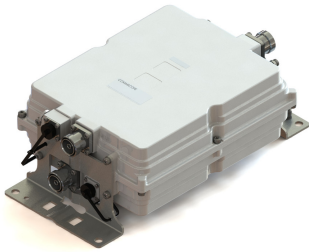

Dual Band Tower Mounted Amplifier, 1800//2100 MHz, 12 dB, 2 BTS & 2 ANT ports, Dual AISG with 2 RET connectors (1 device with 2 sub-units)

- Industry leading PIM performance
- TMA is operating in AISG & CWA mode, Alarm Current consumption CWA mode 190 mA
- 2 input ports and 2 output ports
- Designed to boost UP-Link Coverage and KPIs
- Automatic LNA by-pass function
- Connectors "in line"
- Dual AISG with 2 RET connectors
- 1 device with 2 sub-units
- Built in lightning protection

OBSOLETE

This product was discontinued on: June 30, 2022

Product Classification

Product Type 1-BTS:1-ANT (Uniplex) | Tower mounted amplifier

General Specifications

Color Gray

Modularity 2-Twin

Mounting Pole | Wall

Mounting Pipe Hardware Band clamps (2)

RF Connector Interface 7-16 DIN Female

Dimensions

Height 280 mm | 11.024 in

Width 225 mm | 8.858 in

Depth 104 mm | 4.094 in

Mounting Pipe Diameter Range 50–120 mm

E15S02P87

Outline Drawing

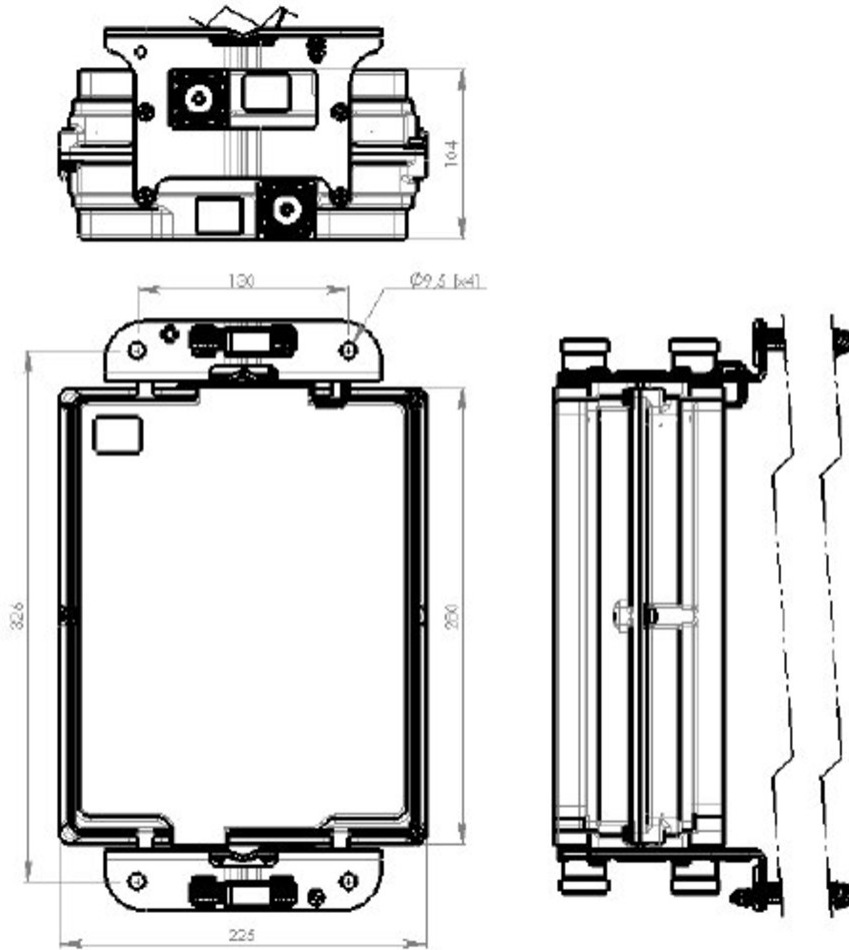

Electrical Specifications

License Band, LNA DCS 1800 | IMT 2100

Electrical Specifications, dc Power/Alarm

dc Switching/Redundancy	Yes
Lightning Surge Current	10 kA
Lightning Surge Current Waveform	8/20 waveform
Voltage	7–30 Vdc
Alarm Current, CWA Mode	190 mA \pm 15 mA

Electrical Specifications, AISG

E15S02P87

AISG Connector	8-pin DIN Female
AISG Connector Standard	IEC 60130-9
Protocol	AISG 2.0
Voltage, AISG Mode	10–30 Vdc

Electrical Specifications

Sub-module	1 2	1 2
Branch	1	1
Port Designation	ANT	ANT
License Band	DCS 1800, LNA	IMT 2100, LNA
Return Loss - Bypass Mode, typical, dB	15	15

Electrical Specifications Rx (Uplink)

Frequency Range, MHz	1710–1785	1920–1980
Bandwidth, MHz	75	60
Gain, nominal, dB	12	12
Noise Figure, typical, dB	1.5	1.5
Group Delay Variation, maximum, ns	30	16
Group Delay Variation Bandwidth, MHz	5	5
Total Group Delay, maximum, ns	100	80
Output IP3, minimum, dBm	20	
Output IP3 at 8 dB, minimum, dBm		20
Return Loss, minimum, dB	18	18
Insertion Loss - Bypass Mode, typical, dB	2	2

Electrical Specifications Tx (Downlink)

Frequency Range, MHz	1805–1880	2110–2170
Bandwidth, MHz	75	60
Insertion Loss, typical, dB	0.4	0.4
Group Delay Variation, maximum, ns	10	4
Group Delay Variation Bandwidth, MHz	5	5
Total Group Delay, maximum, ns	45	25
Return Loss, minimum, dB	18	18
Input Power, RMS, maximum, W	200	200
Input Power, PEP, maximum, W	2000	2000

E15S02P87

3rd Order PIM, typical, dBc

-160

-160

3rd Order PIM Test Method

Two +43 dBm carriers Two +43 dBm carriers

E15S02P87

Block Diagram

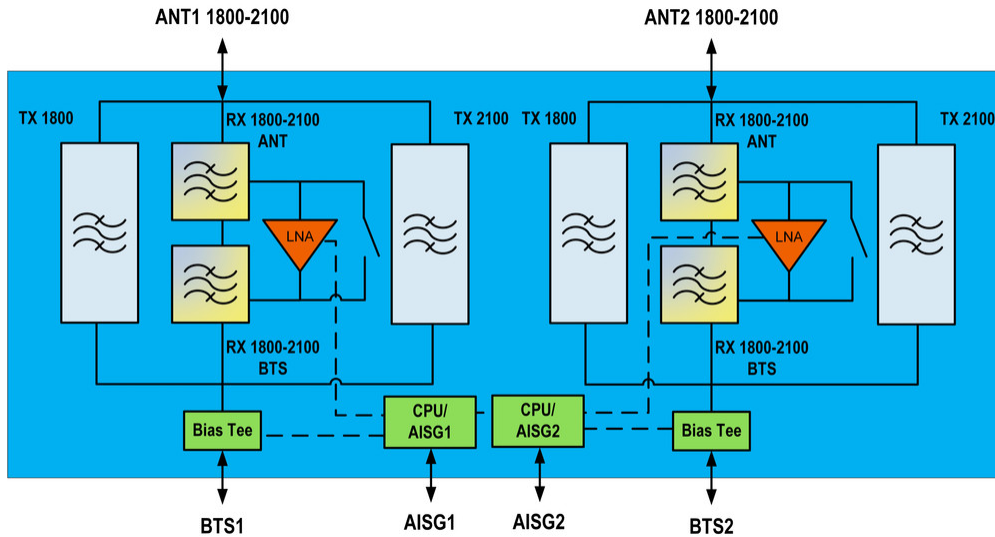

Environmental Specifications

Operating Temperature	-40 °C to +65 °C (-40 °F to +149 °F)
Relative Humidity	Up to 100%
Corrosion Test Method	IEC 60068-2-11, 30 days
Ingress Protection Test Method	IEC 60529:2001, IP67

Packaging and Weights

Included	Mounting hardware
Volume	6.5 L
Weight, net	7 kg 15.432 lb

Regulatory Compliance/Certifications

Agency	Classification
ISO 9001:2015	Designed, manufactured and/or distributed under this quality management system



* Footnotes

License Band, LNA	License Bands that have RxUplink amplification
--------------------------	--