

# E15S02P77

---



Dual Band Tower Mounted Amplifier, 2100//2600, 12 dB, 2 BTS & 4 ANT ports, AISG with 1 RET connectors (2 devices with 2 sub-units each)

## OBSOLETE

This product was discontinued on: December 31, 2023

## Product Classification

**Product Type** 1-BTS:2-ANT (Diplex) | Tower mounted amplifier

## General Specifications

**Color** Gray  
**Modularity** 2-Twin  
**Mounting** Pole | Wall  
**Mounting Pipe Hardware** Band clamps (2)  
**RF Connector Interface** 7-16 DIN Female

## Dimensions

**Height** 203 mm | 7.992 in  
**Width** 192.5 mm | 7.579 in  
**Depth** 102 mm | 4.016 in  
**Mounting Pipe Diameter Range** 50–120 mm

# E15S02P77

## Outline Drawing

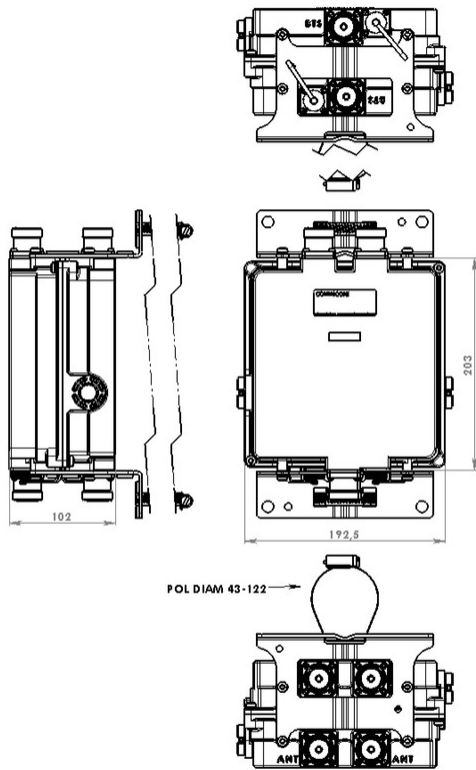

## Electrical Specifications

**License Band, LNA** IMT 2100 | IMT 2600

## Electrical Specifications, dc Power/Alarm

<b>dc Switching/Redundancy</b>	Yes
<b>Lightning Surge Current</b>	10 kA
<b>Lightning Surge Current Waveform</b>	8/20 waveform
<b>Voltage</b>	7–30 Vdc
<b>Alarm Current, CWA Mode</b>	250 mA ±10 mA

## Electrical Specifications, AISG

# E15S02P77

<b>AISG Connector</b>	8-pin DIN Female (2)
<b>AISG Connector Standard</b>	IEC 60130-9
<b>Protocol</b>	AISG 2.0
<b>Voltage, AISG Mode</b>	10–30 Vdc

## Electrical Specifications

<b>Sub-module</b>	<b>1   2</b>	<b>1   2</b>
<b>Branch</b>	1	2
<b>Port Designation</b>	ANT 2100	ANT 2600
<b>License Band</b>	IMT 2100, LNA	IMT 2600, LNA
<b>Return Loss, typical, dB</b>	20	20
<b>Return Loss - Bypass Mode, typical, dB</b>	14	14

## Electrical Specifications Rx (Uplink)

<b>Frequency Range, MHz</b>	<b>1920–1980</b>	<b>2500–2570</b>
<b>Bandwidth, MHz</b>	60	70
<b>Gain, nominal, dB</b>	12	12
<b>Gain Tolerance, dB</b>	±1	±1
<b>Noise Figure, typical, dB</b>	1.5	1.8
<b>Group Delay Variation, maximum, ns</b>	12	10
<b>Group Delay Variation Bandwidth, MHz</b>	5	5
<b>Total Group Delay, maximum, ns</b>	30	40
<b>Output IP3, minimum, dBm</b>	20	20
<b>Return Loss, minimum, dB</b>	17	18
<b>Insertion Loss - Bypass Mode, typical, dB</b>	3	3

## Electrical Specifications Tx (Downlink)

<b>Frequency Range, MHz</b>	<b>2110–2170</b>	<b>2620–2690</b>
<b>Bandwidth, MHz</b>	60	70
<b>Insertion Loss, maximum, dB</b>	0.6	0.6
<b>Insertion Loss, typical, dB</b>	0.5	0.5
<b>Group Delay Variation, maximum, ns</b>	6	3
<b>Group Delay Variation Bandwidth, MHz</b>	5	5
<b>Total Group Delay, maximum, ns</b>	10	12
<b>Return Loss, minimum, dB</b>	17	18

# E15S02P77

---

<b>Input Power, RMS, maximum, W</b>	200	200
<b>Input Power, PEP, maximum, W</b>	2000	2000
<b>3rd Order PIM, maximum, dBc</b>	-153	-153
<b>3rd Order PIM Test Method</b>	Two +43 dBm carriers	Two +43 dBm carriers

# E15S02P77

## Block Diagram

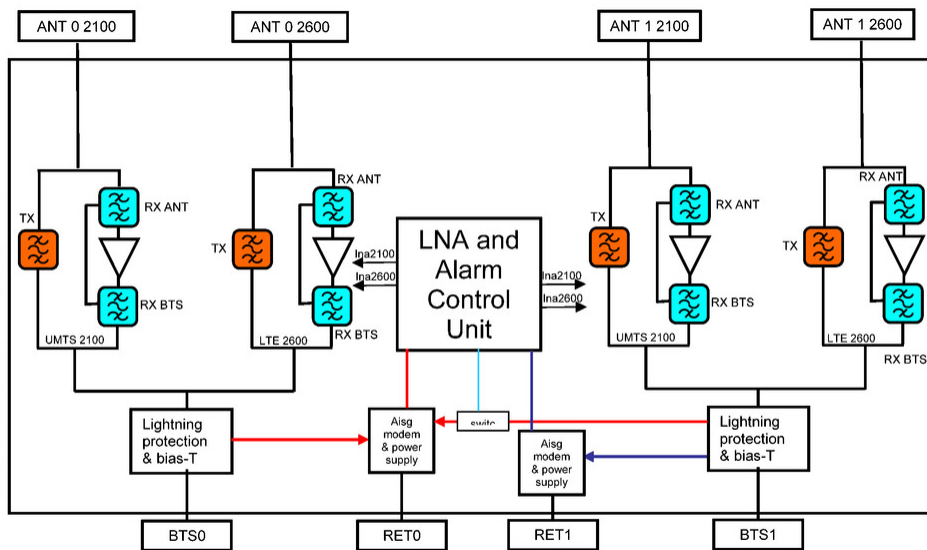

## Environmental Specifications

<b>Operating Temperature</b>	-40 °C to +65 °C (-40 °F to +149 °F)
<b>Relative Humidity</b>	Up to 100%
<b>Corrosion Test Method</b>	IEC 60068-2-11, 30 days
<b>Ingress Protection Test Method</b>	IEC 60529:2001, IP67

## Packaging and Weights

<b>Included</b>	Mounting hardware
<b>Volume</b>	4.1 L
<b>Weight, net</b>	7 kg   15.432 lb

## Regulatory Compliance/Certifications

<b>Agency</b>	<b>Classification</b>
ISO 9001:2015	Designed, manufactured and/or distributed under this quality management system



## \* Footnotes

**License Band, LNA** License Bands that have RxUplink amplification

