

TA-DMDM



7-16 DIN Male to 7-16 DIN Male Low-PIM Adapter

Product Classification

Product Type Adapter

General Specifications

Body Style Straight

Inner Contact Plating Silver

Interface 7-16 DIN Male

Interface 2 7-16 DIN Male

Mounting Angle Straight

Outer Contact Plating Trimetal

Pressurizable No

Dimensions

Width 31.75 mm | 1.25 in

Length 43.8 mm | 1.724 in

Diameter 35.92 mm | 1.414 in

Outline Drawing

TA-DMDM

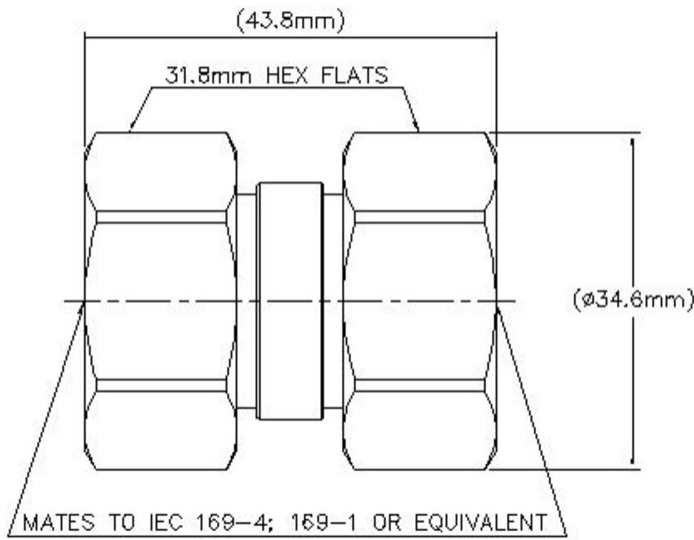

Electrical Specifications

3rd Order IMD at Frequency	-163 dBc @ 1800 MHz
3rd Order IMD Test Method	Two +43 dBm carriers
Average Power at Frequency	1,300.0 W @ 900 MHz
Connector Impedance	50 ohm
dc Test Voltage	4000 V
Inner Contact Resistance, maximum	0.4 mOhm
Insulation Resistance, minimum	10000 MOhm
Operating Frequency Band	0 – 6000 MHz
Outer Contact Resistance, maximum	1.5 mOhm
Peak Power, maximum	28.8 kW
RF Operating Voltage, maximum (vrms)	1200 V

VSWR/Return Loss

Frequency Band	VSWR	Return Loss (dB)
0–3000 MHz	1.032	36.06
3000–6000 MHz	1.135	23.98

Mechanical Specifications

Coupling Nut Proof Torque	50 N-m 442.537 in lb
----------------------------------	------------------------

TA-DMDM

Coupling Nut Proof Torque Method	IEC 61169-4:9.3.6
Coupling Nut Retention Force	800 N 179.847 lbf
Coupling Nut Retention Force Method	IEC 61169-16:9.3.11
Insertion Force	200 N 44.962 lbf
Insertion Force Method	IEC 61169-4:15.2.4
Interface Durability	500 cycles
Interface Durability Method	IEC 61169-4:9.5
Mechanical Shock Test Method	IEC 60068-2-27

Environmental Specifications

Operating Temperature	-55 °C to +85 °C (-67 °F to +185 °F)
Storage Temperature	-65 °C to +125 °C (-85 °F to +257 °F)
Attenuation, Ambient Temperature	20 °C 68 °F
Average Power, Ambient Temperature	40 °C 104 °F
Average Power, Inner Conductor Temperature	100 °C 212 °F
Climatic Sequence Test Method	IEC 60068-1
Corrosion Test Method	IEC 60068-2-11
Damp Heat Steady State Test Method	IEC 60068-2-3
Immersion Depth	1 m
Immersion Test Mating	Mated
Immersion Test Method	IEC 60529:2001, IP68
Thermal Shock Test Method	IEC 60068-2-14
Vibration Test Method	IEC 60068-2-6

Packaging and Weights

Weight, net	118.43 g 0.261 lb
--------------------	---------------------

Regulatory Compliance/Certifications

Agency	Classification
CHINA-ROHS	Below maximum concentration value
ISO 9001:2015	Designed, manufactured and/or distributed under this quality management system
REACH-SVHC	Compliant as per SVHC revision on www.commscope.com/ProductCompliance
ROHS	Compliant

TA-DMDM

UK-ROHS

Compliant



* Footnotes

Immersion Depth

Immersion at specified depth for 24 hours