

L7PDM-RPC



7-16 DIN Male OnePiece™ for 1-5/8 in LDF7-50A cable

OBSOLETE

This product was discontinued on: June 12, 2008

Replaced By:

158EZDM	7-16 DIN Male EZfit® for 1-5/8 in FXL-1873 and AVA7-50 cable
78EZDR	7-16 DIN Male Right Angle EZfit® for 7/8 in FXL-780, AVA5-50, and AVA5-50FX cable
AL7DM-PSA	7-16 DIN Male Positive Stop™ for 1-5/8 in cable

Product Classification

Product Type	Wireless and radiating connector
Product Brand	HELIAX® OnePiece™

General Specifications

Body Style	Straight
Cable Family	LDF7-50A
Inner Contact Attachment Method	Captivated
Inner Contact Plating	Silver
Interface	7-16 DIN Male
Mounting Angle	Straight
Outer Contact Attachment Method	Ball clamp
Outer Contact Plating	Trimetal
Pressurizable	No

Dimensions

Length	106.93 mm 4.21 in
Diameter	62.99 mm 2.48 in
Nominal Size	1-5/8 in

L7PDM-RPC

Outline Drawing

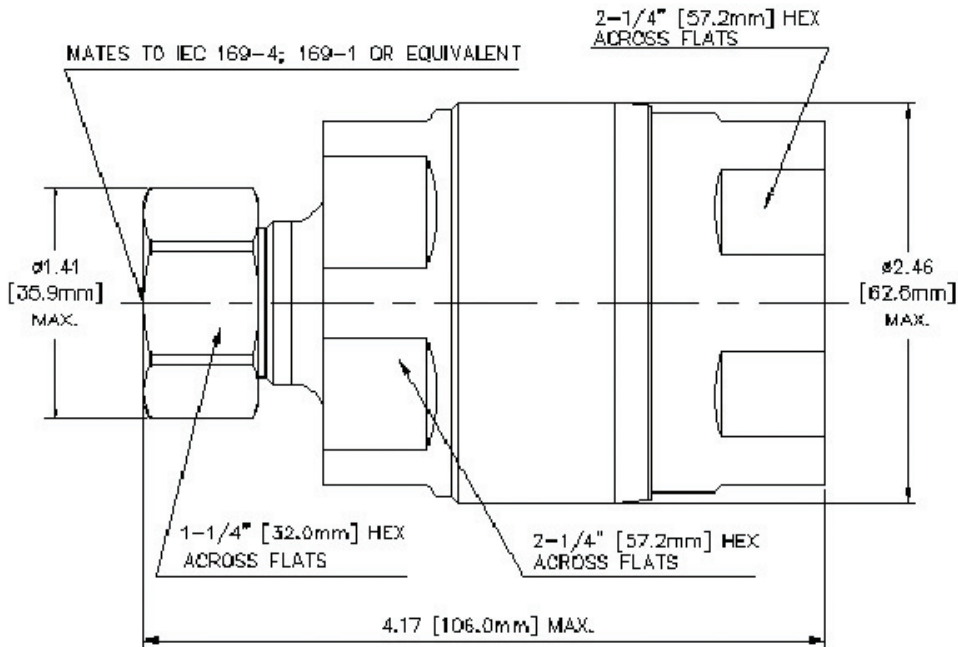

Electrical Specifications

3rd Order IMD at Frequency	-120 dBm @ 910 MHz
3rd Order IMD Test Method	Two +43 dBm carriers
Insertion Loss Coefficient, typical	0.05
Average Power at Frequency	3.0 kW @ 900 MHz
Cable Impedance	50 ohm
Connector Impedance	50 ohm
dc Test Voltage	4000 V
Inner Contact Resistance, maximum	0.8 mOhm
Insulation Resistance, minimum	5000 MOhm
Operating Frequency Band	0 – 2500 MHz
Outer Contact Resistance, maximum	1.5 mOhm
Peak Power, maximum	40 kW
RF Operating Voltage, maximum (vrms)	1415 V
Shielding Effectiveness	-130 dB

L7PDM-RPC

VSWR/Return Loss

Frequency Band	VSWR	Return Loss (dB)
40–1000 MHz	1.029	36.9
1010–2200 MHz	1.032	36.06
2200–2500 MHz	1.058	31

Mechanical Specifications

Attachment Durability	25 cycles
Connector Retention Tensile Force	2,224.11 N 500 lbf
Connector Retention Torque	13.56 N-m 119.998 in lb
Coupling Nut Proof Torque	24.86 N-m 220.003 in lb
Coupling Nut Retention Force	1,000.85 N 225 lbf
Coupling Nut Retention Force Method	MIL-C-39012C-3.25, 4.6.22
Insertion Force	200.17 N 45 lbf
Insertion Force Method	IEC 61169-1:15.2.4
Interface Durability	500 cycles
Interface Durability Method	IEC 61169-16:9.5
Mechanical Shock Test Method	MIL-STD-202F, Method 213B, Test Condition C

Environmental Specifications

Operating Temperature	-55 °C to +85 °C (-67 °F to +185 °F)
Storage Temperature	-55 °C to +85 °C (-67 °F to +185 °F)
Attenuation, Ambient Temperature	20 °C 68 °F
Average Power, Ambient Temperature	40 °C 104 °F
Corrosion Test Method	MIL-STD-1344A, Method 1001.1, Test Condition A
Immersion Depth	1 m
Immersion Test Mating	Unmated
Immersion Test Method	IEC 60529:2001, IP68
Moisture Resistance Test Method	MIL-STD-202F, Method 106F
Thermal Shock Test Method	MIL-STD-202F, Method 107G, Test Condition A-1, Low Temperature -55 °C
Vibration Test Method	IEC 60068-2-6
Water Jetting Test Mating	Unmated

L7PDM-RPC

Water Jetting Test Method IEC 60529:2001, IP66

Packaging and Weights

Weight, net 717 g | 1.581 lb

* Footnotes

Insertion Loss Coefficient, typical $0.05\sqrt{\text{freq}}$ (GHz) (not applicable for elliptical waveguide)

Immersion Depth Immersion at specified depth for 24 hours