

A7PDF-RPC

7-16 DIN Female OnePiece™ for 1-5/8 in AVA7-50 cable

OBSOLETE

This product was discontinued on: May 7, 2008

Replaced By:

AL7DF-PS	7-16 DIN Female Positive Stop™ for 1-5/8 in cable
AL7DF-PSA	7-16 DIN Female Positive Stop™ for 1-5/8 in cable

Product Classification

Product Type	Wireless and radiating connector
Product Brand	HELIAX® OnePiece™

General Specifications

Body Style	Straight
Cable Family	AVA7-50
Inner Contact Attachment Method	Captivated
Inner Contact Plating	Silver
Interface	7-16 DIN Female
Mounting Angle	Straight
Outer Contact Attachment Method	Ball clamp
Outer Contact Plating	Trimetal
Pressurizable	No

Dimensions

Length	104.9 mm 4.13 in
Diameter	62.74 mm 2.47 in
Nominal Size	1-5/8 in

Outline Drawing

A7PDF-RPC

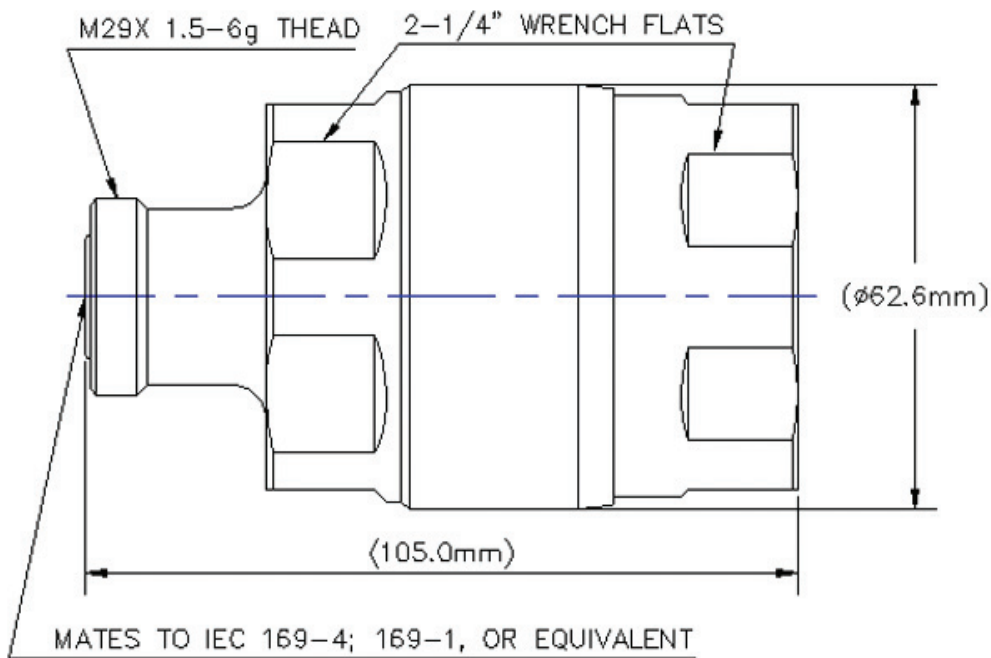

Electrical Specifications

3rd Order IMD at Frequency	-120 dBm @ 910 MHz
3rd Order IMD Test Method	Two +43 dBm carriers
Insertion Loss Coefficient, typical	0.05
Average Power at Frequency	3.0 kW @ 900 MHz
Cable Impedance	50 ohm
Connector Impedance	50 ohm
dc Test Voltage	4000 V
Inner Contact Resistance, maximum	0.8 mOhm
Insulation Resistance, minimum	5000 MOhm
Operating Frequency Band	0 – 2500 MHz
Outer Contact Resistance, maximum	1.5 mOhm
Peak Power, maximum	40 kW
RF Operating Voltage, maximum (vrms)	1415 V
Shielding Effectiveness	-130 dB

VSWR/Return Loss

Frequency Band	VSWR	Return Loss (dB)
824–960 MHz	1.02	40.09
1710–1880 MHz	1.02	40.09
1850–1990 MHz	1.02	40.09
1910–2200 MHz	1.02	40.09
2210–2500 MHz	1.049	32.43

Mechanical Specifications

Attachment Durability	25 cycles
Connector Retention Tensile Force	2,224.11 N 500 lbf
Connector Retention Torque	13.6 N-m 120.37 in lb
Insertion Force	200.17 N 45 lbf
Insertion Force Method	IEC 61169-1:15.2.4
Interface Durability	50 cycles
Interface Durability Method	IEC 61169-4:9.5
Mechanical Shock Test Method	MIL-STD-202F, Method 213B, Test Condition C

Environmental Specifications

Operating Temperature	-55 °C to +85 °C (-67 °F to +185 °F)
Storage Temperature	-55 °C to +85 °C (-67 °F to +185 °F)
Attenuation, Ambient Temperature	20 °C 68 °F
Average Power, Ambient Temperature	40 °C 104 °F
Corrosion Test Method	MIL-STD-1344A, Method 1001.1, Test Condition A
Immersion Depth	1 m
Immersion Test Mating	Unmated
Immersion Test Method	IEC 60529:2001, IP68
Moisture Resistance Test Method	MIL-STD-202F, Method 106F
Thermal Shock Test Method	MIL-STD-202F, Method 107G, Test Condition A-1, Low Temperature -55 °C
Vibration Test Method	IEC 60068-2-6
Water Jetting Test Mating	Unmated
Water Jetting Test Method	IEC 60529:2001, IP66

A7PDF-RPC

Packaging and Weights

Weight, net 675 g | 1.488 lb

Regulatory Compliance/Certifications

Agency	Classification
ISO 9001:2015	Designed, manufactured and/or distributed under this quality management system



* Footnotes

Insertion Loss Coefficient, typical 0.05√freq (GHz) (not applicable for elliptical waveguide)

Immersion Depth Immersion at specified depth for 24 hours