

TMAT23B78-21A | E15R07P02

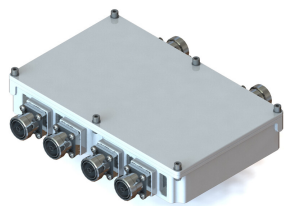

Twin Tower Mounted Amplifier WCS with 700-850 Bypass AISG

OBSOLETE

This product was discontinued on: **March 30, 2024**

Product Classification

Product Type Tower mounted amplifier

General Specifications

RF Connector Interface 7-16 DIN Female

RF Connector Interface Body Style Long neck

Dimensions

Height 170 mm | 6.693 in

Width 270 mm | 10.63 in

Depth 50 mm | 1.969 in

TMAT23B78-21A | E15R07P02

Outline Drawing

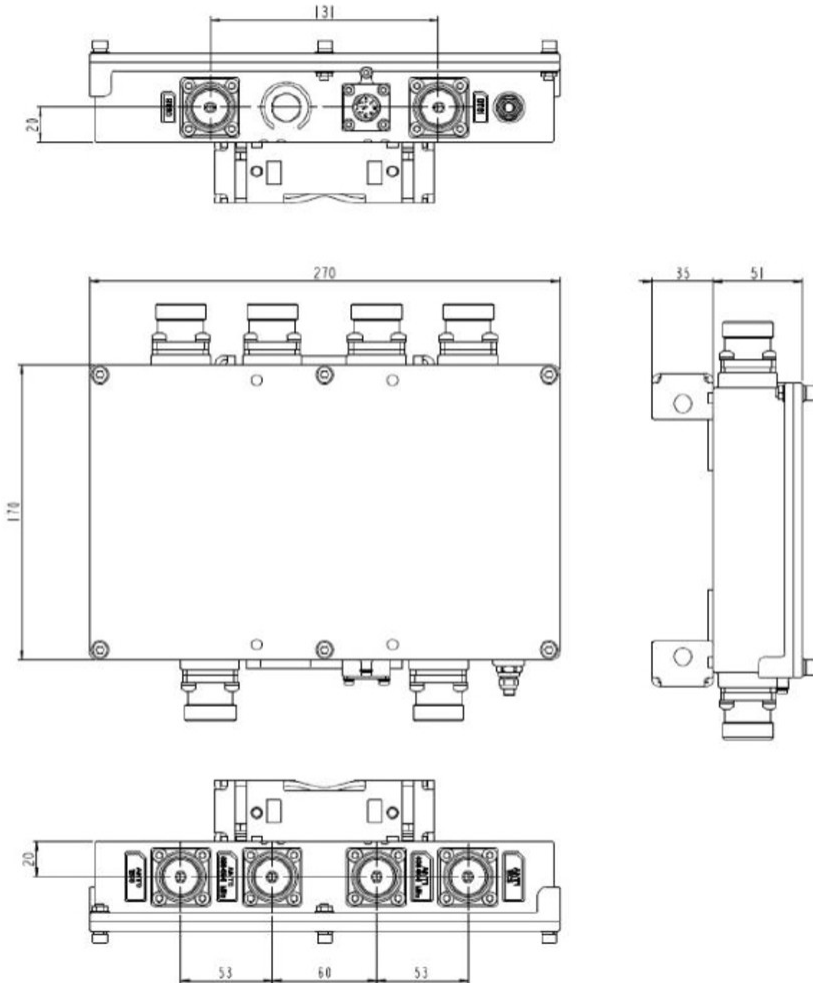

Electrical Specifications

License Band, Band Pass CEL 850 | LMR 750 | LMR 800 | USA 700 | USA 750

License Band, LNA WCS 2300

Electrical Specifications, Common Port

Composite Power, RMS 200 W

Electrical Specifications, dc Power/Alarm

Lightning Surge Current 10 kA

Lightning Surge Current Waveform 8/20 waveform

Operating Current at Voltage 210 mA @ 12 Vdc

TMAT23B78-21A | E15R07P02

Voltage, CWA Mode 10–18 Vdc

Electrical Specifications, AISG

AISG Carrier 2.176 MHz ± 100 ppm
AISG Connector 8-pin DIN Female
AISG Connector Standard IEC 60130-9
Protocol AISG 1.1 | AISG 2.0
Voltage, AISG Mode 10–30 Vdc

Electrical Specifications

Sub-module	1 2	1 2
Branch	1	2
Port Designation	ANT 1 698-894	ANT 0 WCS
AISG 2.0 Device Subunit		E25A01P03 1/2
License Band	LMR 750, Band Pass LMR 800, Band Pass USA 700, Band Pass USA 750, Band Pass CEL 850, Band Pass	WCS 2300, LNA

Electrical Specifications Rx (Uplink)

Frequency Range, MHz	2305–2315
Gain, nominal, dB	13
Gain Tolerance, dB	1
Noise Figure, typical, dB	1.7

Electrical Specifications Tx (Downlink)

Frequency Range, MHz	2350–2360
Insertion Loss, maximum, dB	0.6
Insertion Loss, typical, dB	0.5
Total Group Delay, maximum, ns	50
Return Loss, minimum, dB	18
Return Loss, typical, dB	20
Input Power, RMS, maximum, W	200
Input Power, PEP, maximum, W	3000
3rd Order PIM, typical, dBc	-153
3rd Order PIM Test Method	Two +43 dBm carriers

Electrical Specifications, Band Pass

Frequency Range, MHz	698-894
Insertion Loss, maximum, dB	0.2
Return Loss, minimum, dB	18
Return Loss, typical, dB	20
Isolation, minimum, dB	60
Input Power, RMS, maximum, W	200
Input Power, PEP, maximum, W	3000
3rd Order PIM, maximum, dBc	-153

Block Diagram

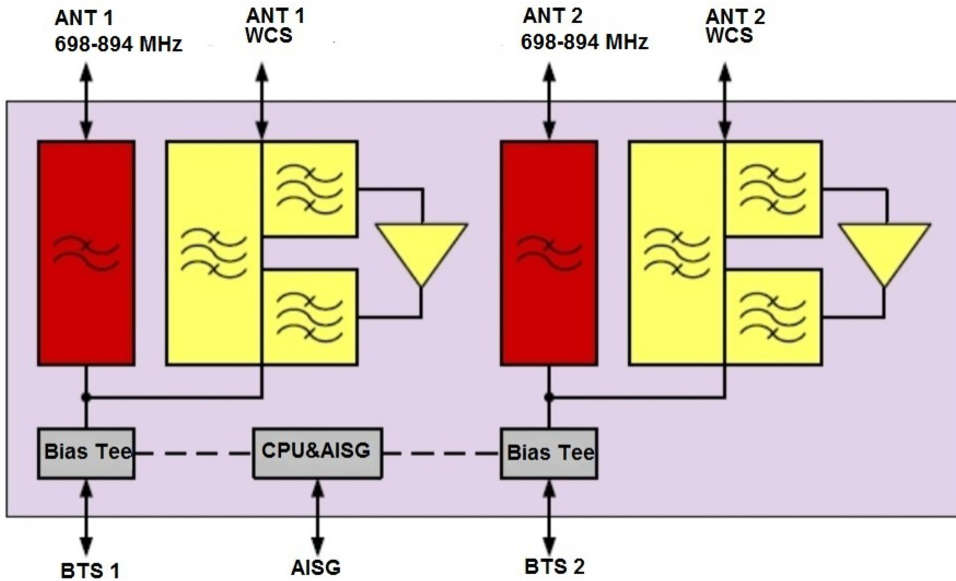

Environmental Specifications

Operating Temperature	-40 °C to +65 °C (-40 °F to +149 °F)
Relative Humidity	Up to 100%
Corrosion Test Method	IEC 60068-2-11, 30 days
Ingress Protection Test Method	IEC 60529:2001, IP67

Packaging and Weights

Weight, net 4.2 kg | 9.259 lb

* Footnotes

License Band, Band Pass License Bands that are to be passed through with no amplification

License Band, LNA License Bands that have RxUplink amplification