

E15V90P34



Twin Quadplexer, dc bypass on all ports

- Industry leading PIM performance
- Twin configuration
- dc/AISG pass-through on all frequency ports
- Suitable for feeders cables reduction
- Designed for network Modernization, introduction of LTE2600 on existing site

OBSOLETE

This product was discontinued on: December 31, 2023

Replaced By:

E16V90P34

Twin Quadplexer, dc bypass on all ports, with 4.3-10 connectors

Product Classification

Product Type Quadplexer

General Specifications

Product Family	CBC7182126
Color	Gray
Common Port Label	PORT 0 COM
Modularity	2-Twin
Mounting	Pole Wall
Mounting Pipe Hardware	Band clamps (2)
RF Connector Interface	7-16 DIN Female
RF Connector Interface Body Style	Medium neck

Dimensions

Height	210 mm 8.268 in
Width	250 mm 9.843 in
Depth	141 mm 5.551 in
Mounting Pipe Diameter Range	42.6–122 mm

Outline Drawing

E15V90P34

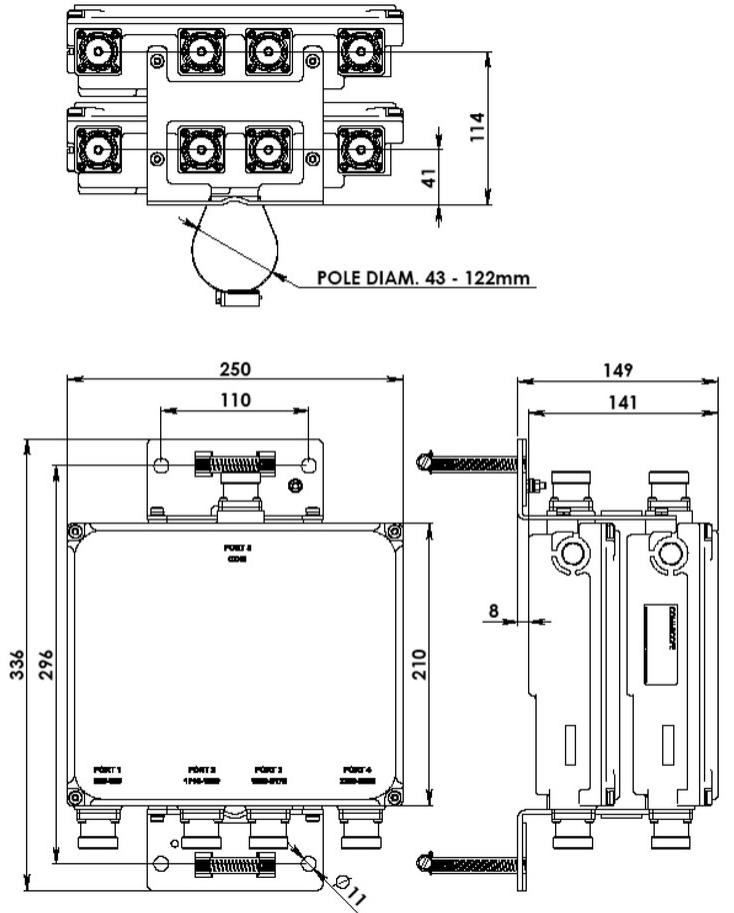

Electrical Specifications

Impedance	50 ohm
License Band, Band Pass	APT 700 AWS 2000 CEL 850 CEL 900 DCS 1800 EDD 800 IMT 2100 IMT 2600 LMR 800 LMR 900 PCS 1900

Electrical Specifications, dc Power/Alarm

dc/AISG Pass-through, combiner	Branch 1 Branch 2 Branch 3 Branch 4
dc/AISG Pass-through, demultiplexer	Branch 1 Branch 2 Branch 3 Branch 4
Lightning Surge Current	5 kA
Lightning Surge Current Waveform	8/20 waveform

Electrical Specifications, AISG

AISG Carrier	2176 KHz \pm 100 ppm
---------------------	------------------------

E15V90P34

Insertion Loss, maximum	0.5 dB
Return Loss, minimum	10 dB

Electrical Specifications

Sub-module	1 2	1 2	1 2	1 2
Branch	1	2	3	4
Port Designation	PORT 1 698-960	PORT 2 1710-1880	PORT 3 1920-2170	PORT 4 2300-2690
License Band	CEL 850, Band Pass CEL 900, Band Pass EDD 800, Band Pass LMR 800, Band Pass LMR 900, Band Pass	DCS 1800, Band Pass	IMT 2100, Band Pass AWS 2000, Band Pass PCS 1900, Band Pass	IMT 2600, Band Pass

Electrical Specifications, Band Pass

Frequency Range, MHz	698–960	1710–1880	1920–2170	2300–2690
Insertion Loss, typical, dB	0.2	0.3	0.3	0.25
Return Loss, typical, dB	20	20	20	20
Isolation, minimum, dB	50	50	50	50
Input Power, RMS, maximum, W	300	300	300	250
3rd Order PIM, typical, dBc	-160	-160	-160	-160
3rd Order PIM Test Method	Two +43 dBm carriers	Two +43 dBm carriers	Two +43 dBm carriers	Two +43 dBm carriers

Block Diagram

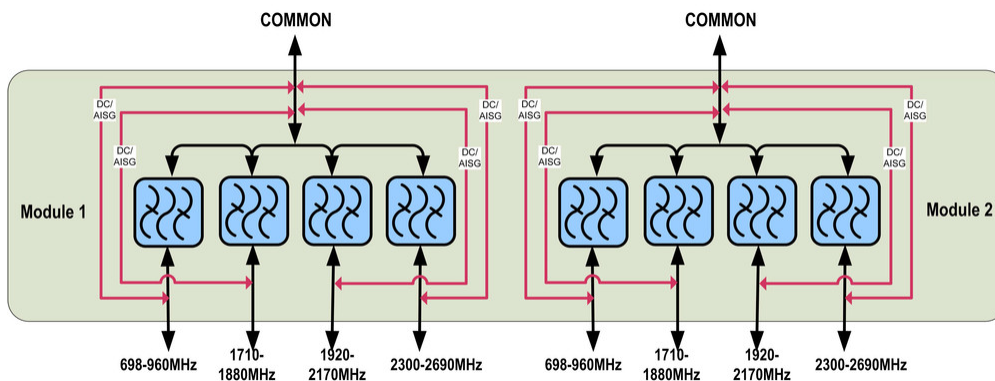

Mechanical Specifications

Wind Speed, maximum	216 km/h (134 mph)
----------------------------	--------------------

Environmental Specifications

E15V90P34

Operating Temperature	-40 °C to +65 °C (-40 °F to +149 °F)
Relative Humidity	15%–100%
Corrosion Test Method	IEC 60068-2-11, 30 days
Ingress Protection Test Method	IEC 60529:2001, IP67
Vibration Test Method	IEC 60068-2-6

Packaging and Weights

Included	Mounting hardware
Weight, net	10 kg 22.046 lb