

# E14R50P01

---

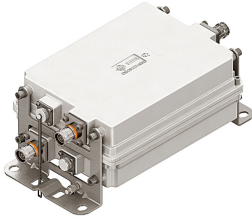

Tower Mounted Amplifier, Twin 800MHz with AISG 2.0, with 4.3-10 connectors

- Industry leading PIM performance
- New 4.3-10 connectors for improved PIM performance and size reduction
- Designed to boost UP-Link Coverage and KPIs

## Product Classification

**Product Type** 1-BTS:1-ANT (Uniplex) | Tower mounted amplifier

## General Specifications

**Color** Gray  
**Modularity** 2-Twin  
**Mounting** Pole | Wall  
**Mounting Pipe Hardware** Band clamps (2)  
**RF Connector Interface** 4.3-10 Female

## Dimensions

**Height** 237 mm | 9.331 in  
**Width** 179 mm | 7.047 in  
**Depth** 96 mm | 3.78 in

# E14R50P01

## Outline Drawing

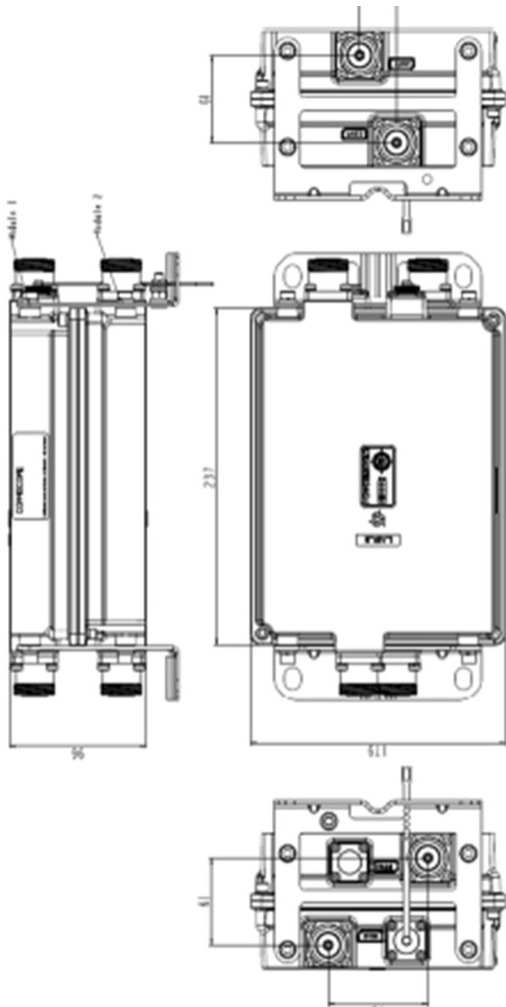

## Electrical Specifications

**License Band, Band Pass** EDD 800

## Electrical Specifications, dc Power/Alarm

**Lightning Surge Current** 10 kA

**Lightning Surge Current Waveform** 8/20 waveform

## Electrical Specifications, AISG

**AISG Carrier** 2.176 MHz  $\pm$  100 ppm

**AISG Connector** 8-pin DIN Female

**AISG Connector Standard** IEC 60130-9

# E14R50P01

---

<b>Default Protocol</b>	AISG 2.0
<b>Protocol</b>	AISG 1.1   AISG 2.0
<b>Voltage, AISG Mode</b>	10–30 Vdc

## Electrical Specifications

<b>Sub-module</b>	<b>1</b>
<b>Branch</b>	1
<b>Port Designation</b>	ANT
<b>License Band</b>	EDD 800, Band Pass
<b>Return Loss, typical, dB</b>	20

## Electrical Specifications Rx (Uplink)

<b>Frequency Range, MHz</b>	<b>832–862</b>
<b>Bandwidth, MHz</b>	30
<b>Gain, nominal, dB</b>	12
<b>Gain Tolerance, dB</b>	±1.0
<b>Noise Figure, typical, dB</b>	1.5
<b>Total Group Delay, typical, ns</b>	193
<b>Insertion Loss - Bypass Mode, typical, dB</b>	2.5

## Electrical Specifications Tx (Downlink)

<b>Frequency Range, MHz</b>	<b>791–821</b>
<b>Bandwidth, MHz</b>	30
<b>Insertion Loss, typical, dB</b>	0.5
<b>Total Group Delay, typical, ns</b>	72
<b>Return Loss, typical, dB</b>	20
<b>Input Power, RMS, maximum, W</b>	150
<b>Input Power, PEP, maximum, W</b>	3000
<b>3rd Order PIM, typical, dBc</b>	-160
<b>5th Order PIM Test Method</b>	2 x 20 W CW tones

## Block Diagram

# E14R50P01

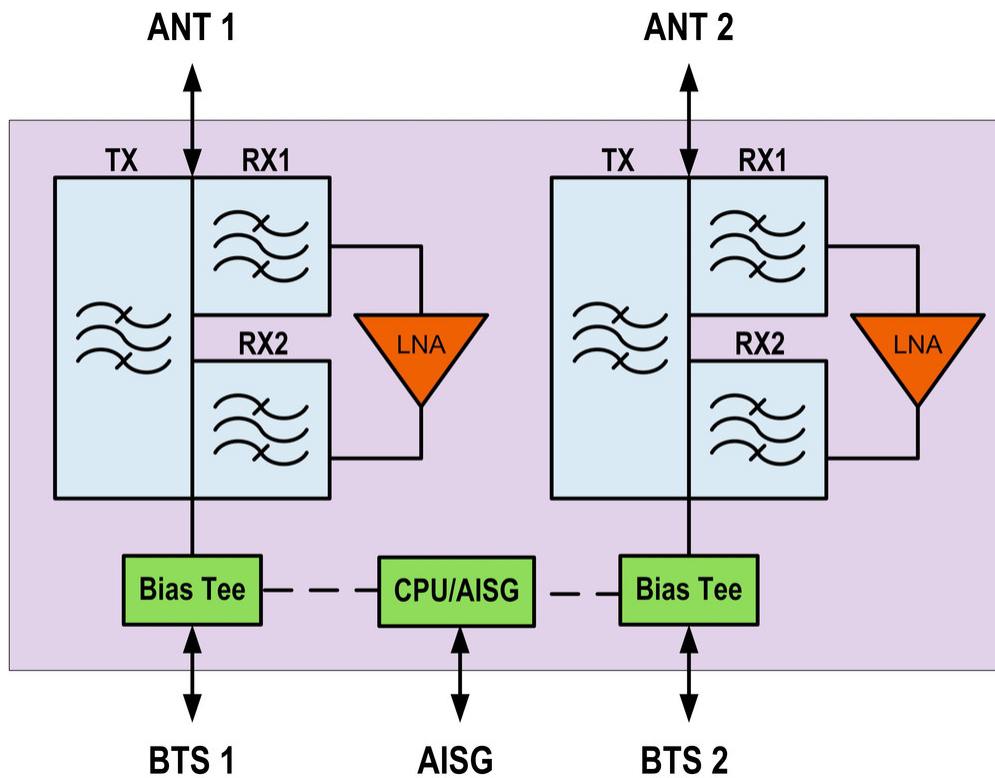

## Material Specifications

**Finish** Painted

## Environmental Specifications

**Operating Temperature** -40 °C to +65 °C (-40 °F to +149 °F)

**Corrosion Test Method** IEC 60068-2-11, 30 days

**Ingress Protection Test Method** IEC 60529:2001, IP67

## Packaging and Weights

**Included** Mounting hardware

**Weight, net** 6 kg | 13.228 lb

## \* Footnotes

**License Band, Band Pass** License Bands that are to be passed through with no amplification