

E12F05P90

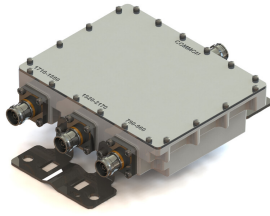

Triplexer 900/1800/2100, dc bypass on 1800 MHz port, with 4.3-10 connectors

- New 4.3-10 connectors for improved PIM performance and size reduction
- Industry leading PIM performance
- Suitable for feeders cables reduction

OBSOLETE

This product was discontinued on: December 31, 2023

Replaced By:

E12F05P92

Triplexer 900/1800/2100, dc bypass on all ports, with 4.3-10 connectors

Product Classification

Product Type Triplexer

General Specifications

Product Family	CBC81821
Color	Gray
Common Port Label	Common
Modularity	1-Single
Mounting	Pole Wall
Mounting Pipe Hardware	Band clamps (2)
RF Connector Interface	4.3-10 Female
RF Connector Interface Body Style	Medium neck

Dimensions

Height	151 mm 5.945 in
Width	56 mm 2.205 in
Depth	192 mm 7.559 in
Mounting Pipe Diameter Range	40–160 mm

E12F05P90

Outline Drawing

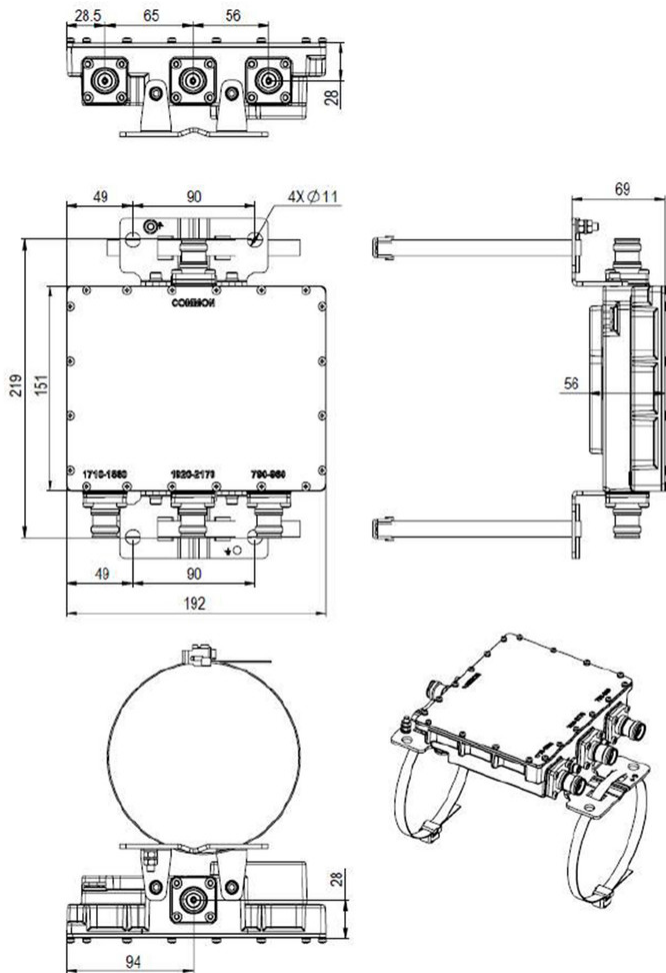

Electrical Specifications

Impedance	50 ohm
License Band, Band Pass	CEL 850 CEL 900 DCS 1800 EDD 800 IMT 2100 LMR 800 LMR 900

Electrical Specifications, dc Power/Alarm

dc/AISG Pass-through, combiner	Branch 2
dc/AISG Pass-through, demultiplexer	Branch 2
Lightning Surge Current	10 kA
Lightning Surge Current Waveform	8/20 waveform

E12F05P90

Electrical Specifications

Sub-module	1	1	1
Branch	1	2	3
Port Designation	790-960	1710-1880	1920-2170
License Band	CEL 850, Band Pass CEL 900, Band Pass EDD 800, Band Pass LMR 800, Band Pass LMR 900, Band Pass	DCS 1800, Band Pass	IMT 2100, Band Pass

Electrical Specifications, Band Pass

Frequency Range, MHz	790-960	1710-1880	1920-2170
Insertion Loss, typical, dB	0.15	0.2	0.2
Return Loss, minimum, dB	21	21	21
Return Loss, typical, dB	24	24	24
Isolation, minimum, dB	50	50	50
Input Power, RMS, maximum, W	350	250	250
Input Power, PEP, maximum, W	3000	2500	2500
3rd Order PIM, typical, dBc	-160	-160	-160
3rd Order PIM Test Method	Two +43 dBm carriers	Two +43 dBm carriers	Two +43 dBm carriers

Block Diagram

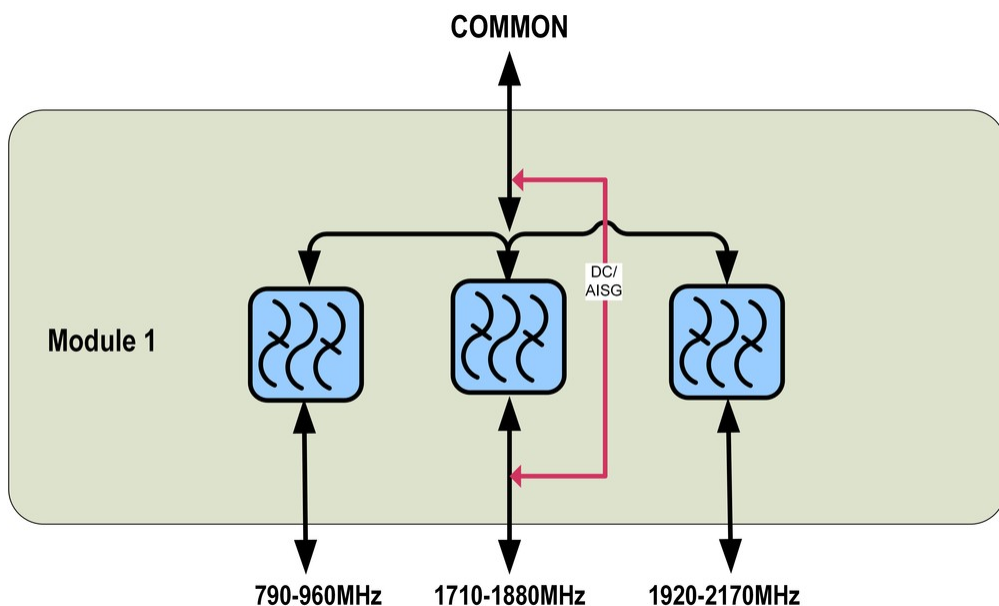

E12F05P90

Environmental Specifications

Operating Temperature	-40 °C to +60 °C (-40 °F to +140 °F)
Relative Humidity	Up to 100%
Corrosion Test Method	IEC 60068-2-11, 30 days
Ingress Protection Test Method	IEC 60529:2001, IP67

Packaging and Weights

Included	Mounting hardware
Volume	1.6 L
Weight, net	2.6 kg 5.732 lb

Regulatory Compliance/Certifications

Agency	Classification
ISO 9001:2015	Designed, manufactured and/or distributed under this quality management system

