

CBC71726-DH-2X | E11F01P92

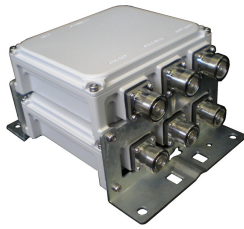

2X Triplexer 698-960/1710-2170/2300-2600, dc bypass on port 3

OBSOLETE

This product was discontinued on: December 31, 2023

Replaced By:

E12F01P78

Twin Triplexer 698-960//1710-2170//2300-2690 MHz, dc bypass on all port

Product Classification

Product Type Triplexer

General Specifications

Product Family CBC71726
Color Gray
Common Port Label COMM
Modularity 2-Twin
Mounting Pole | Wall
Mounting Pipe Hardware Band clamps (2)
RF Connector Interface 7-16 DIN Female
RF Connector Interface Body Style Medium neck

Dimensions

Height 153 mm | 6.024 in
Width 127 mm | 5 in
Depth 182 mm | 7.165 in
Mounting Pipe Diameter Range 42.6–122 mm

CBC71726-DH-2X | E11F01P92

Outline Drawing

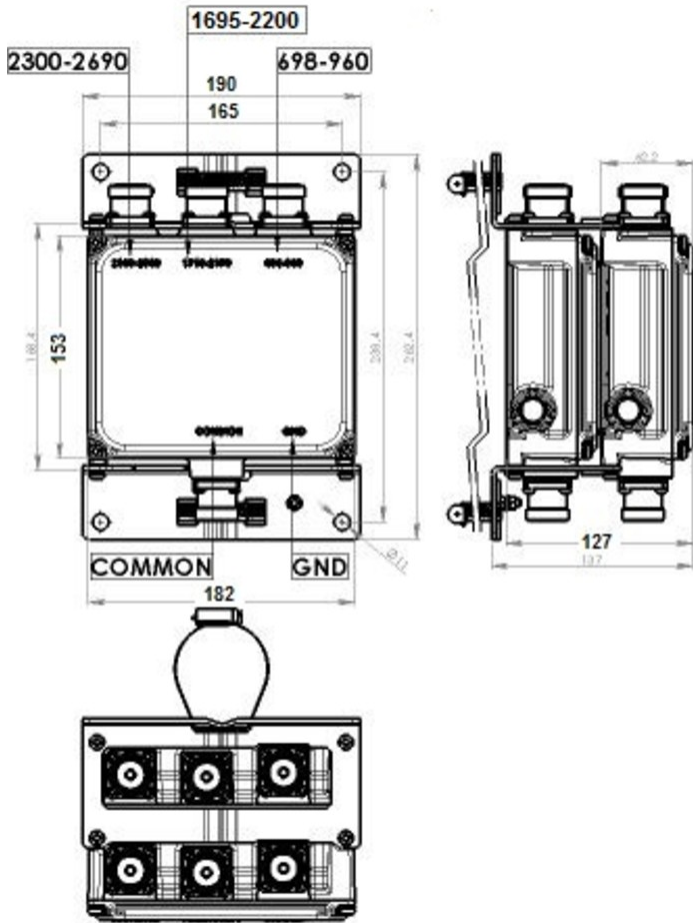

Electrical Specifications

Impedance	50 ohm
License Band, Band Pass	APT 700 AWS 1700 CEL 850 CEL 900 DCS 1800 EDD 800 IMT 2100 IMT 2600 LMR 750 LMR 800 LMR 900 PCS 1900 USA 700 USA 750 WCS 2300

Electrical Specifications, dc Power/Alarm

dc/AISG Pass-through, combiner	Branch 3
dc/AISG Pass-through, demultiplexer	Branch 3
Lightning Surge Current	5 kA
Lightning Surge Current Waveform	8/20 waveform

Electrical Specifications

Sub-module	1 2	1 2	1 2
Branch	1	2	3
Port Designation	698-960	1710-2170	2300-2690
License Band	APT 700, Band Pass CEL 850, Band Pass CEL 900, Band Pass EDD 800, Band Pass LMR 750, Band Pass LMR 800, Band Pass LMR 900, Band Pass USA 700, Band Pass USA 750, Band Pass	AWS 1700, Band Pass DCS 1800, Band Pass IMT 2100, Band Pass PCS 1900, Band Pass	IMT 2600, Band Pass WCS 2300, Band Pass

Electrical Specifications, Band Pass

Frequency Range, MHz	698-960	1710-2170	2300-2690
Insertion Loss, typical, dB	0.15	0.2	0.25
Return Loss, minimum, dB	18	18	18
Return Loss, typical, dB	20	20	20
Isolation, minimum, dB	50	50	50
3rd Order PIM, maximum, dBc	-155	-155	-155
3rd Order PIM, typical, dBc	-155	-155	-153
3rd Order PIM Test Method	2 x 20 W CW tones	2 x 20 W CW tones	2 x 20 W CW tones

Block Diagram

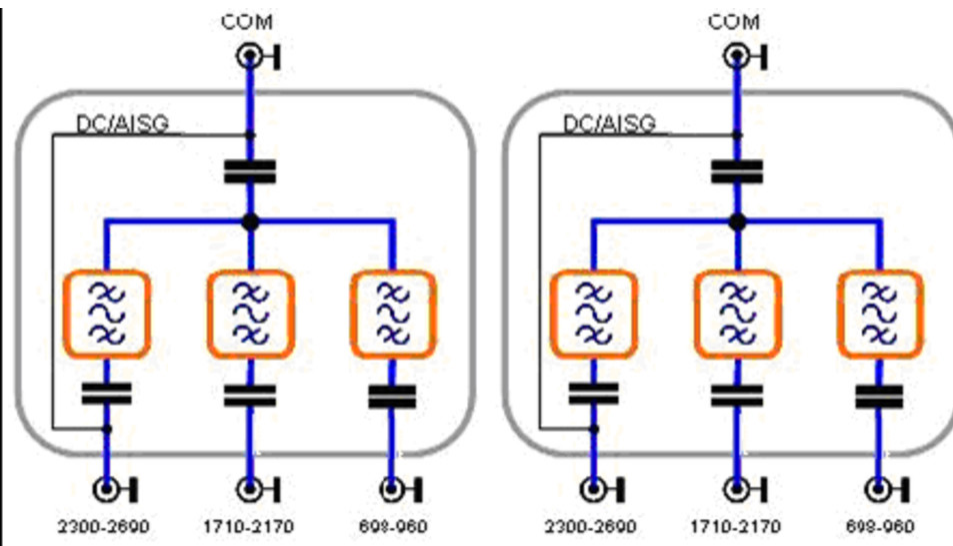

Environmental Specifications

CBC71726-DH-2X | E11F01P92

Operating Temperature -40 °C to +60 °C (-40 °F to +140 °F)

Relative Humidity Up to 100%

Ingress Protection Test Method IEC 60529:2001, IP67

Packaging and Weights

Included Mounting hardware

Volume 3.9 L

Weight, net 6.3 kg | 13.889 lb

Regulatory Compliance/Certifications

Agency

ISO 9001:2015



Classification

Designed, manufactured and/or distributed under this quality management system