

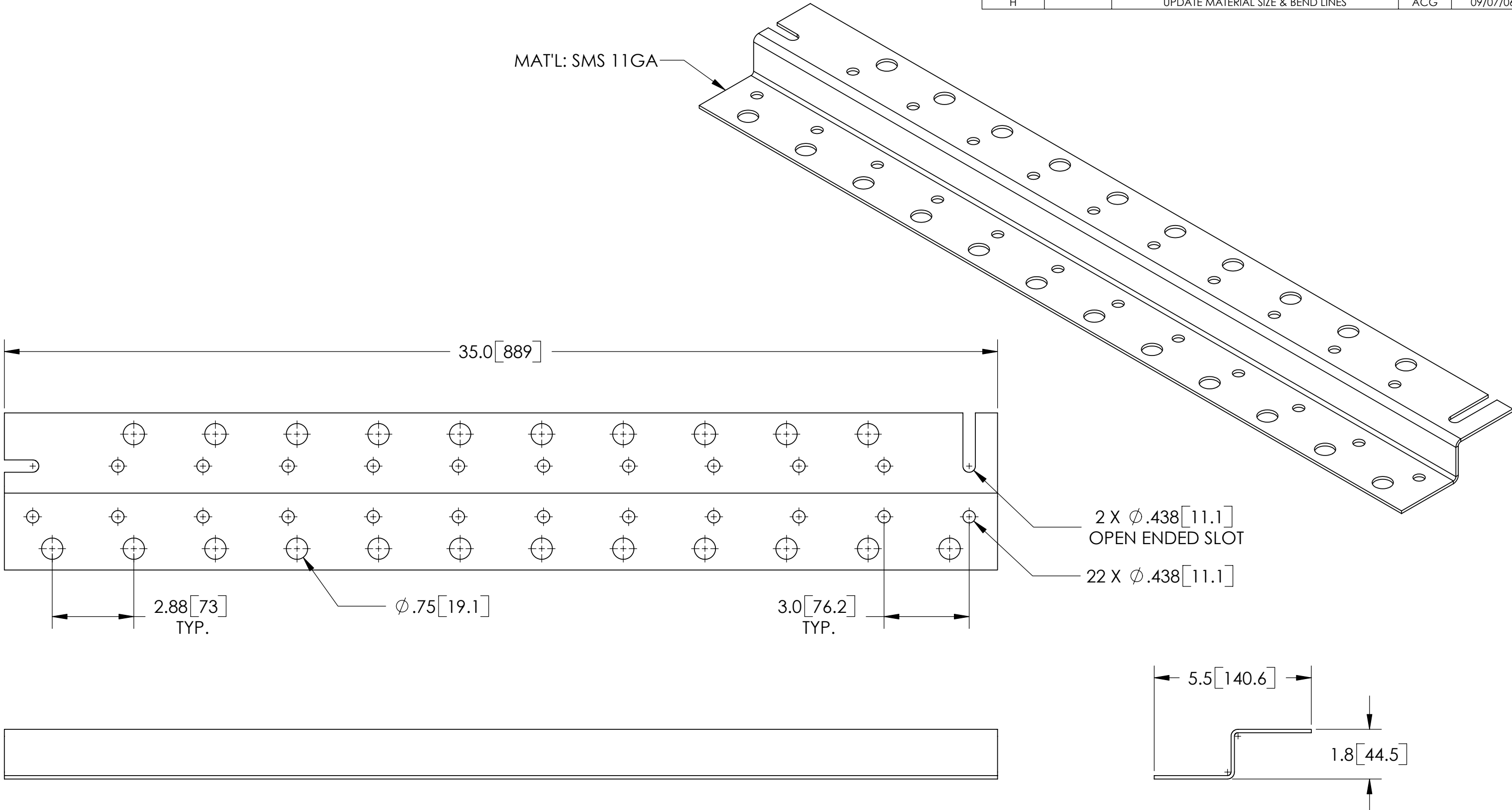

REVISIONS				
REV.	ZONE	DESCRIPTION	BY	DATE
G		ADDED SLOTS TO EASE INSTALL	AW	10/25/04
H		UPDATE MATERIAL SIZE & BEND LINES	ACG	09/07/06

MAT'L: SMS 11GA



NOTES:
1. ALL METRIC DIMENSIONS ARE IN BRACKETS.

<small>These drawings and specifications are the proprietary property of ANDREW CORPORATION and may be used only for the specific purpose authorized in writing by Andrew Corporation.</small> ALL DIMENSIONS ARE IN INCHES U.O.S. TOLERANCES UNLESS OTHERWISE SPECIFIED: .X = ± .06 ANGLES ±2° .XX = ± .03 FRACTIONS ±1/32 .XXX = ± .010 REMOVE BURRS AND BREAK EDGES .005 DO NOT SCALE THIS PRINT	DRAWN BY: ACG	SHEET: 1 of 1	PART NUMBER: ZB-HI2
	CHECKED BY: TP	SCALE: NTS	DESCRIPTION: HORIZONTAL Z-BRACKET, 12 RUNS OF COAX
	DATE: 09/07/06	MATERIAL: A568	DRAWING TYPE: ASSEMBLY DRAWING
	REVISION: H	FINISH: GALV A123	 ORLAND PARK, IL. 60462 U.S.A.
	WEIGHT: 7.78 LBS		