

# FiberGuide® FlexVertical™ System

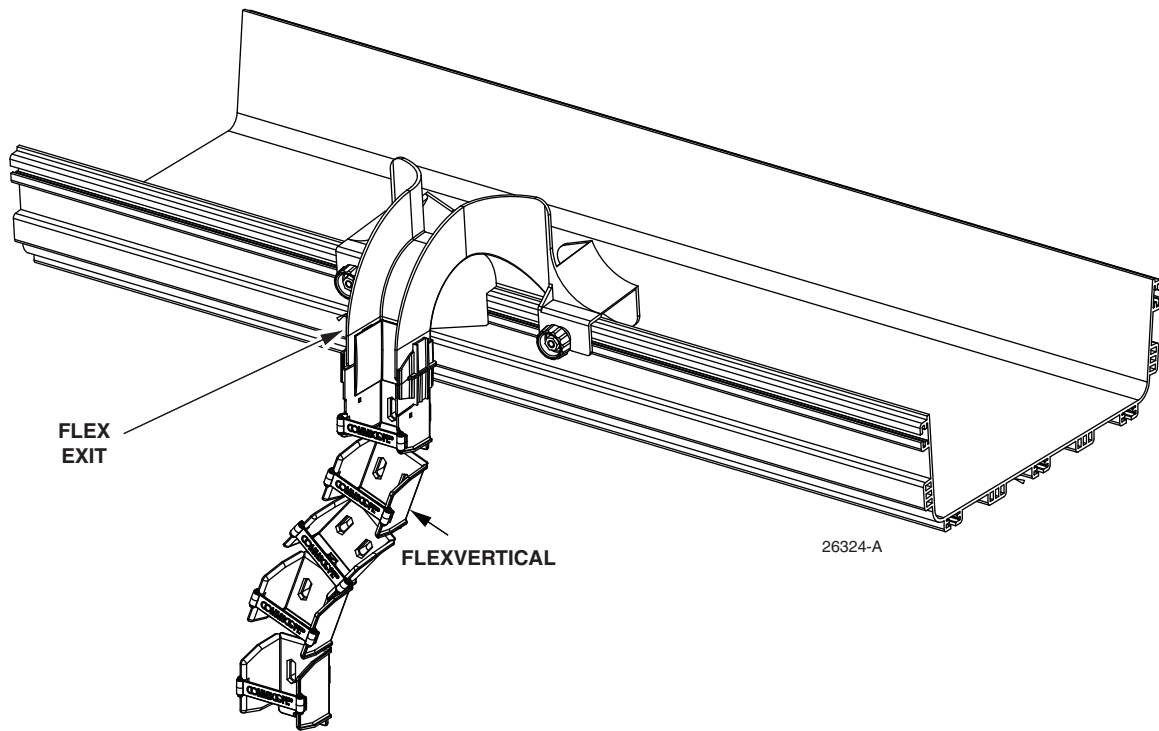

**FlexVertical Single Trough Extension**

Content	Page
<b>INTRODUCTION</b> .....	<b>2</b>
Revision History .....	2
Trademark Information .....	2
Disclaimer .....	2
<b>1 GENERAL DESCRIPTION</b> .....	<b>2</b>
<b>2 INSTALLATION</b> .....	<b>3</b>
2.1 2x2 Single Trough Extension .....	4
2.2 2x2 Dual Trough Extension .....	6
2.3 2x2 Rack Mount Extension .....	8
<b>3 PRODUCT INFORMATION AND TECHNICAL ASSISTANCE</b> .....	<b>10</b>

## INTRODUCTION

This user manual describes the FlexVertical product line and tells how to install FlexVertical on an existing FiberGuide system.

## Revision History

ISSUE	DATE	REASON FOR CHANGE
1	January 2017	Original.
2	February 2017	Art caption corrected. New corporate URLs added.

## Trademark Information

CommScope (logo), CommScope, FiberGuide, and FlexVertical are trademarks.

## Disclaimer

CommScope reserves the right to revise and improve its products as it sees fit. This publication describes the state of the product at the time of its publication, and may not reflect the product at all times in the future. Specification and price change privileges reserved.

## 1 GENERAL DESCRIPTION

- ▶ **Note:** FlexVertical is intended for vertical installation.
- ▶ **Note:** FlexVertical is not intended to be installed in Plenum air space.

FlexVertical is a FiberGuide add-on consisting of hand-configurable components that install on an existing FiberGuide exit (or similar fitting such as a downspout). Once in place, an “extension” composed of these components can be flexed to provide a vertical conduit through mis-aligned or constricted spaces.

The “2x2 main” is the basic component in a FlexVertical construction. Each 2x2 main has a ball and socket joint by which it may be attached to another 2x2 main or mating component. The ball and socket joint permits the 2x2 main to be bent at an angle of up to 30 degrees left to right or front to back with respect to the component it is joined to.

Figure 1 shows the three kits documented in this user manual;

- 2x2 single trough extension;
- 2x2 dual trough extension; and
- 2x2 rack mount vertical extension.

Figure 1 also shows several key features of the FlexVertical system, including its ability to be joined to an existing FiberGuide system, the flexibility provided by the ball and socket joint, and the ability to transition from a 4 inch FiberGuide system to dual 2 inch troughs.

The “universal adapter” shown in the figure provides the transition to the existing FiberGuide system and has a break off side panel that, in a rack mount extension, can be used to provide a horizontal exit from the extension to rack mount equipment.

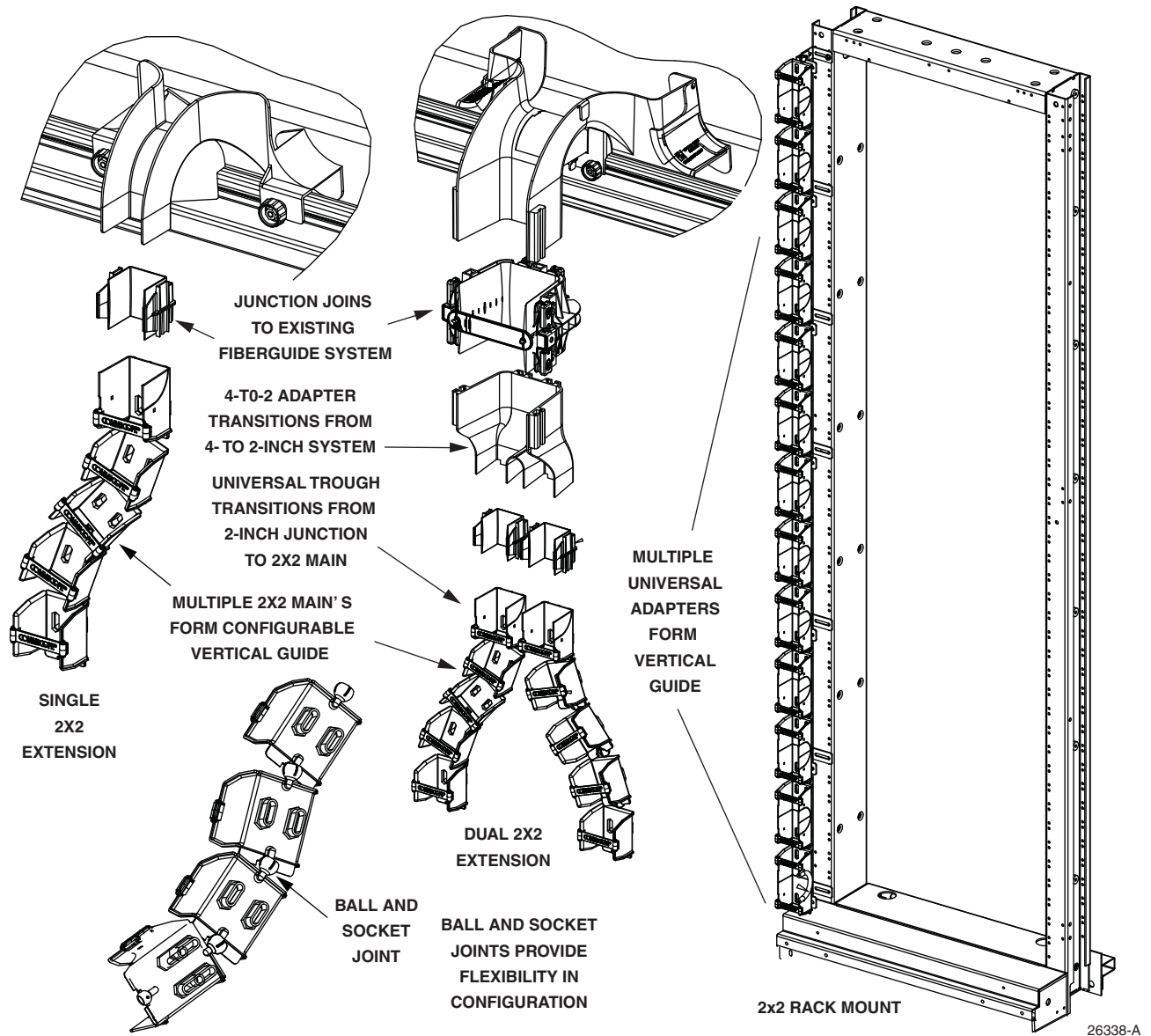

**Figure 1. FlexVertical Features**

## 2 INSTALLATION

Refer to the following topics:

- [Topic 2.1, 2x2 Single Trough Extension, on Page 4;](#)
- [Topic 2.2, 2x2 Dual Trough Extension, on Page 6;](#) or

- Topic 2.3, 2x2 Rack Mount Extension, on Page 8.

## 2.1 2x2 Single Trough Extension

To create a 2x2 single trough extension, use the following procedure referring to Figure 2.

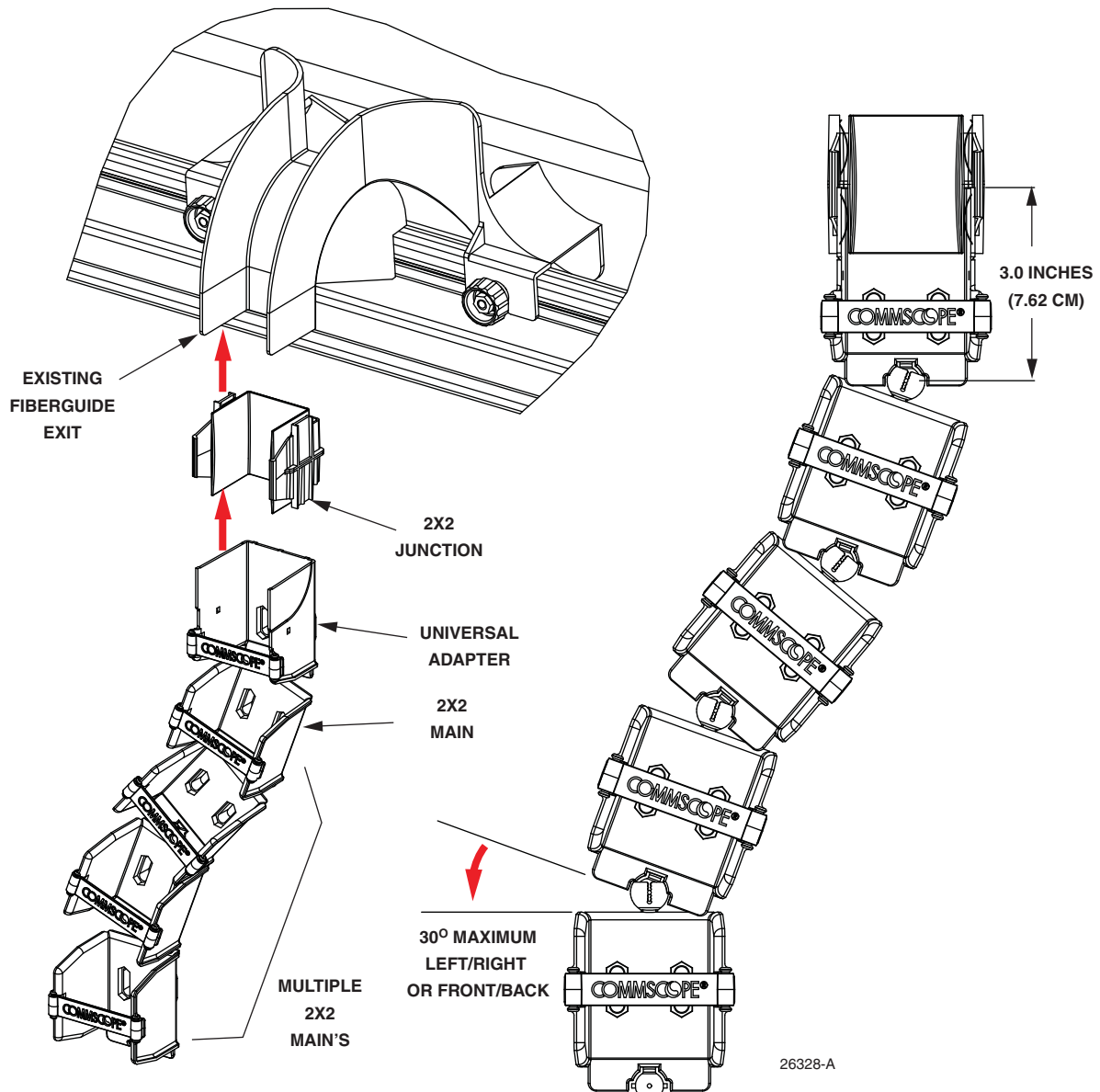
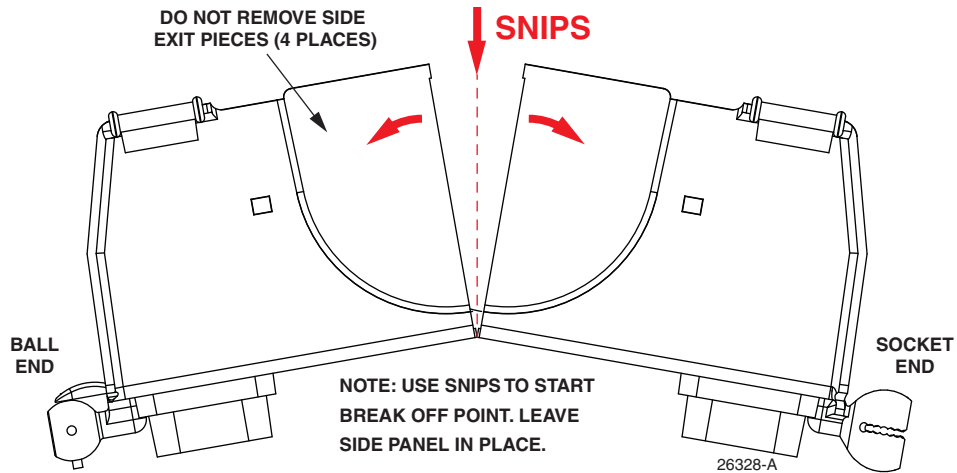

Figure 2. Single 2x2 Extension

1. Identify the existing FiberGuide 2-inch exit (or downspout) on which the extension will be installed, and visually plan how the extension will be routed.

2. Install the 2x2 junction on the existing exit as shown in [Figure 2](#).
3. Using a snips, separate the universal adapter at the break line into two parts (a ball end and a socket end), as shown in [Figure 3](#). Take care not to break off the side panel.



**Figure 3. Breaking the Universal Adapter Into Ball End and Socket End**

4. Insert the ball end half of the universal adapter into the junction by inserting the side panels into the grooves of the junction, as shown in [Figure 2](#).
5. Install a 2x2 main on the universal junction, as shown in [Figure 2](#), by mating the socket end of one component with the ball end of the other.
6. Install a second 2x2 main on the first 2x2 main, again by mating the ball and socket as shown in [Figure 4](#).

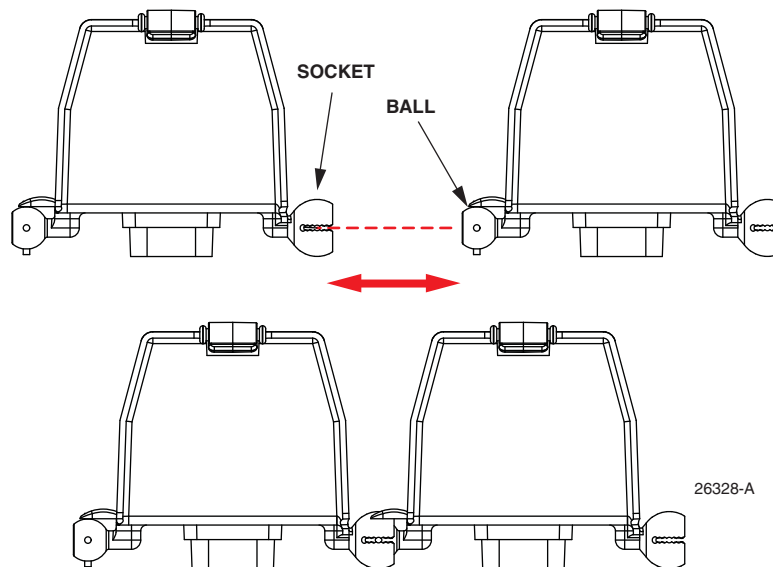

**Figure 4. Joining 2x2 Main's**

7. Continue adding 2x2 main's as needed to form an extension of the desired length.
8. Position the extension as desired, noting the 30 degrees maximum bend.
9. Add socket end of universal adapter to end of run if attaching to vertical 2x2 trough.
10. The individual 2x2 main's and/or universal adapter can be secured to a bracket or frame with #12-24 threaded holes or clearance holes as shown in [Figure 5](#).

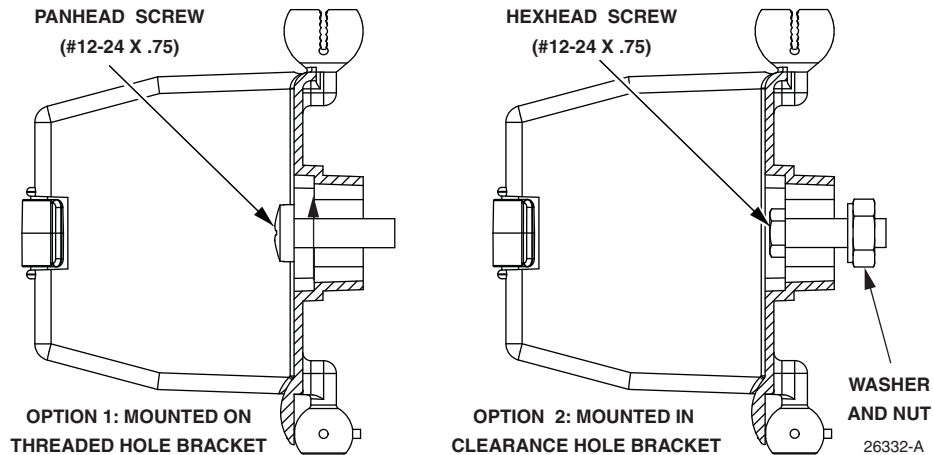

**Figure 5. Hardware Options for Securing 2x2 Main to Bracket or Frame**

## 2.2 2x2 Dual Trough Extension

To create a dual 2x2 extension, use the following procedure referring to [Figure 6](#).

1. Identify the existing FiberGuide 4-inch exit (or downspout) on which the extension will be installed, and visually plan how the extension will be routed.
2. Install the 4x4 junction on the existing exit.
3. Install the 4x4 to dual 2x2 adapter on the 4x4 junction.
4. Install 2x2 junctions on the dual 2x2 adapter.
5. Using a snips, separate a universal adapter at the break line into two parts (a ball end and a socket end), as shown in [Figure 3 on Page 5](#). Take care not to break off the side panels.
6. Repeat the previous step to separate a second universal adapter into two parts.
7. Insert the ball end halves of the universal adapters into the two 2x2 junction by inserting the side panels into the grooves of the junctions.
8. Do the following for each of two troughs of the dual extension, referring to [Figure 6](#):
  - a. Install a 2x2 main on the universal junction by mating the socket end of one component with the ball end of the other.
  - b. Install a second 2x2 main on the first 2x2 main, again by mating the ball and socket.
  - c. Continue adding 2x2 main's as needed to form an extension of the desired length.

- d. Position the extension as desired, noting the 30 degrees maximum bend.
9. Add socket end of universal adapter to end of run if attaching to vertical 2x2 trough.
10. The individual 2x2 main's and/or universal adapter can be secured to a bracket or frame with #12-24 threaded holes or clearance holes as shown in [Figure 5 on Page 6](#).

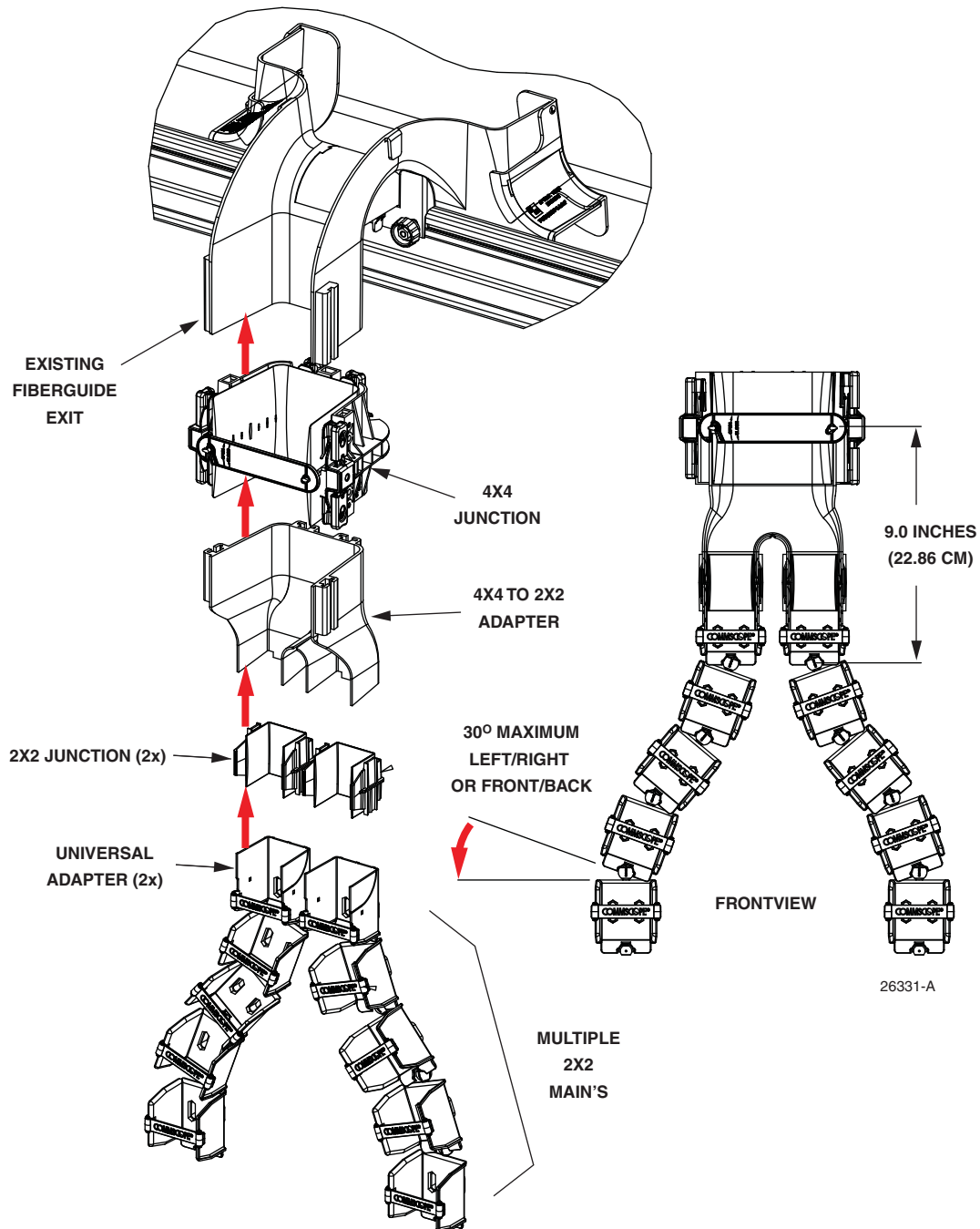

**Figure 6. Dual 2x2 Extension**

## 2.3 2x2 Rack Mount Extension

To create a 2x2 rack mount extension, use the following procedure, referring to [Figure 7](#).

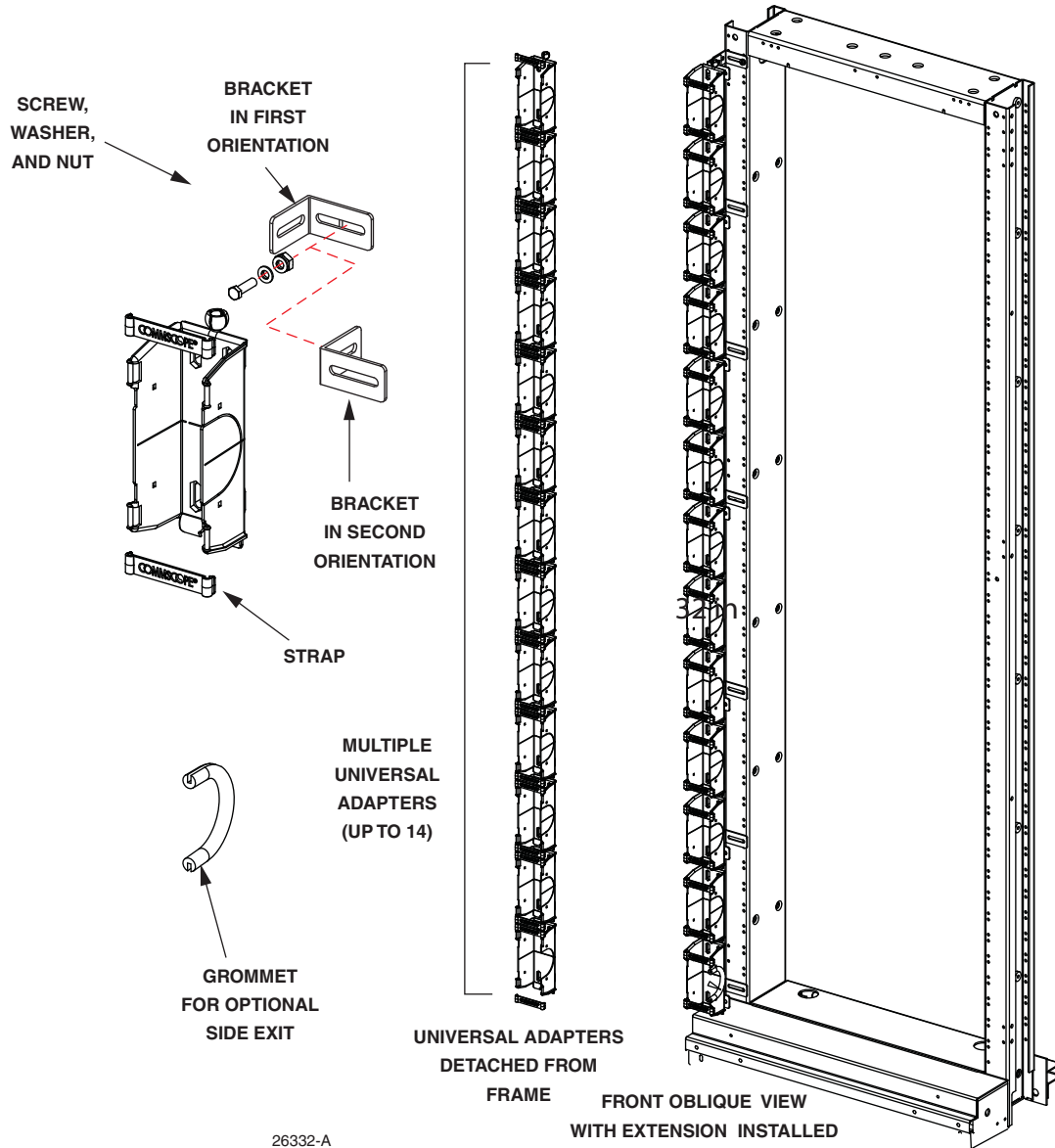

26332-A

**Figure 7. 2x2 Rack Mount Extension**

1. If needed, install the mounting brackets on the frame, selecting from the mounting options shown in [Figure 8](#).
2. Construct a chain of universal adapters as shown in [Figure 9](#) by joining the ball and socket joints. To do this, orient the socket end on one universal adapter to mate it with the ball end on another universal trough. Snap the universal adapters together.

► **Note:** Universal adapters will be installed on the frame with ball end down.



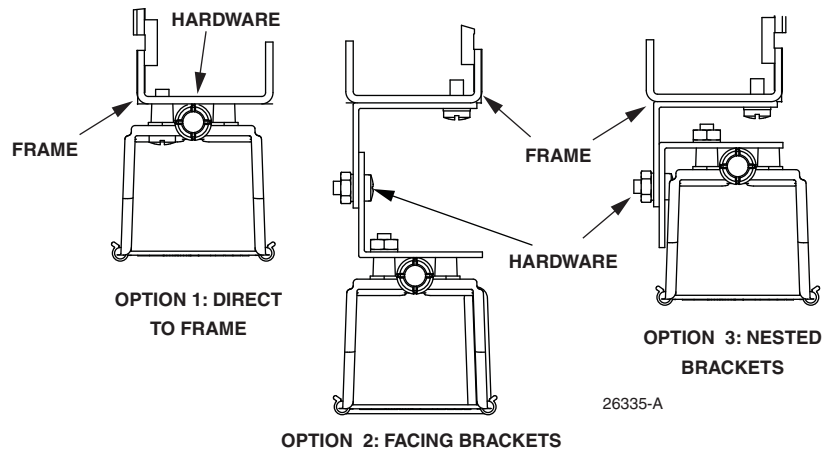

Figure 8. Mounting Options for Rack Mount Extension

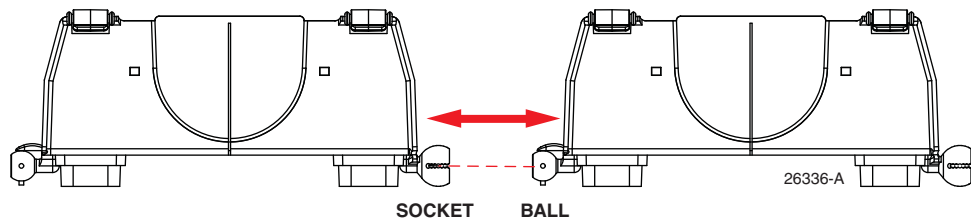

Figure 9. Joining Two Universal Troughs

3. If side exits will be used for patch cord routing, snip top tab on side to be removed, press out the side pieces, and install a grommet (provided) as shown in Figure 10.

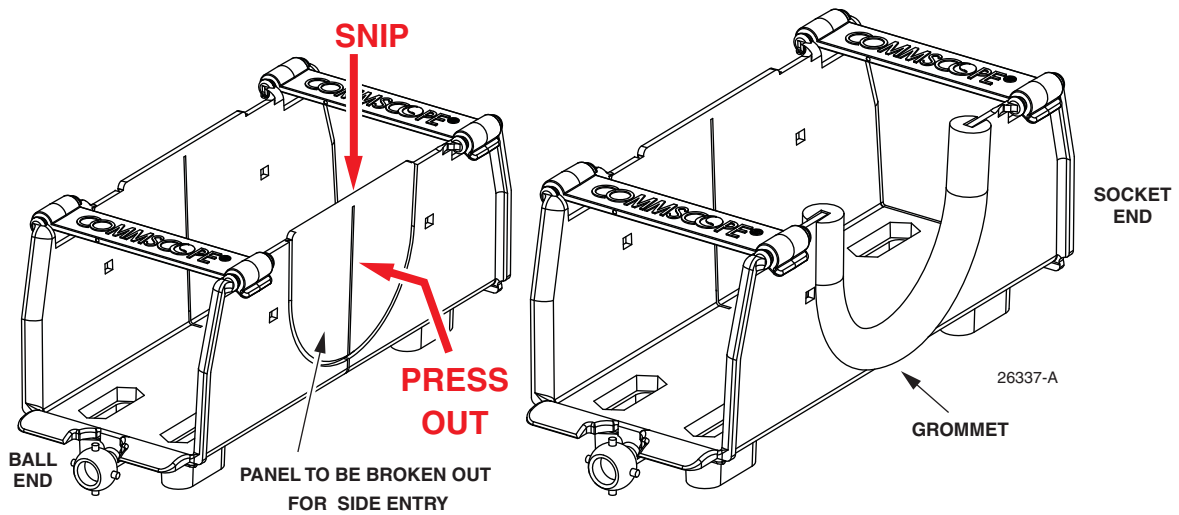

Figure 10. Universal Trough Side Cable Entry

- Secure the universal adapters to the mounting brackets or directly to the rack using the hardware provided, as shown in Figure 11.

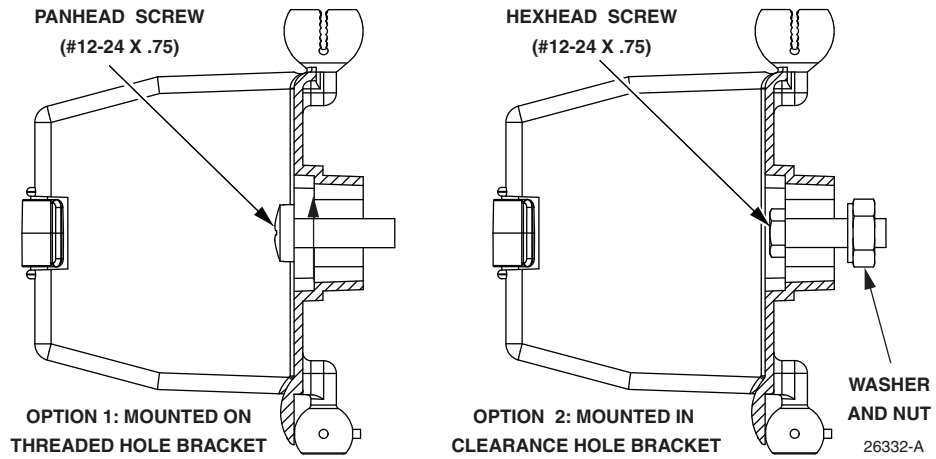

Figure 11. Securing Universal Trough to Rack

### 3 PRODUCT INFORMATION AND TECHNICAL ASSISTANCE

<http://www.commscope.com/SupportCenter>

