

ITEM	PART NO.	DESCRIPTION	QTY.	WEIGHT	NOTE NO.
1	RK3SHK	HARDWARE KIT FOR RK-3S	1	240.17 LBS	
2	RK36	KICKER ARM SUPPORT TUBE , 36"	3	16.02 LBS	

REVISIONS				
REV.	ECN	DESCRIPTION	BY	DATE
A	8000005392	INITIAL RELEASE	MSM	09/22/14
B	8000009889	MTC306503W WAS MTC306503	RJC	9/9/2015

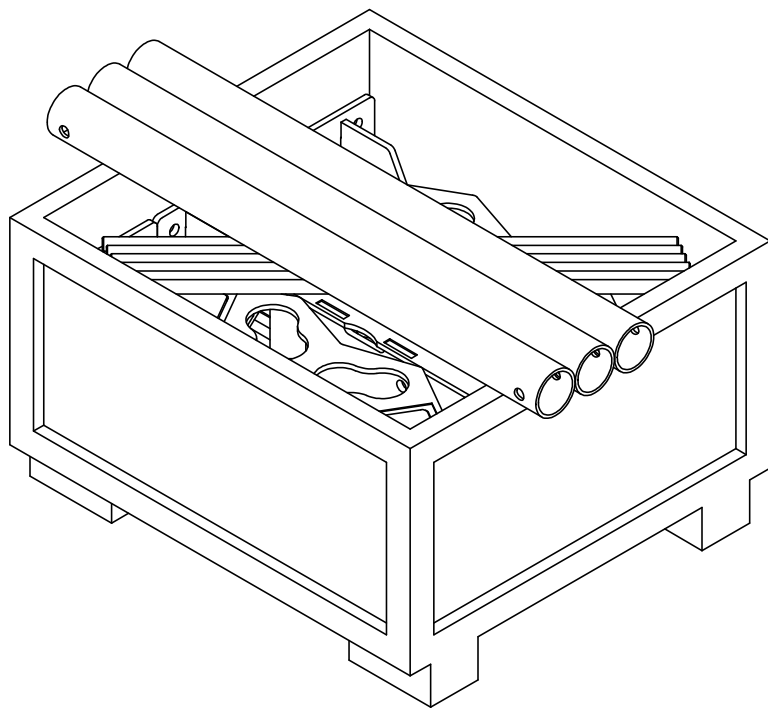

NOTES:
1. CUSTOMER ASSEMBLY SHEETS 2-3.

<p>These drawings and specifications are the proprietary property of CommScope Inc. and may be used only for the specific purpose authorized in writing by CommScope Inc.</p> <p>ALL DIMENSIONS ARE IN INCHES U.O.S. TOLERANCES UNLESS OTHERWISE SPECIFIED: .X = ± .12 ANGLES ±2° .XX = ± .06 FRACTIONS ±1/32 .XXX = ± .03</p> <p>REMOVE BURRS AND BREAK EDGES .005</p> <p>DO NOT SCALE THIS PRINT</p>	DRAWN BY: MSM	SHEET: 1 of 3	PART NUMBER: RK-36-3S
	CHECKED BY: TP	SCALE: NTS	DESCRIPTION: REINFORCEMENT KIT, 3-SECOR, 36", 10-30
	DATE: 09/22/14	MATERIAL: A36, A500	DRAWING TYPE: SHOP DRAWING
	REVISION: B	FINISH: GALV A123	<p>Hickory, NC 28602 U.S.A.</p>
	WEIGHT: 288.23 LBS		

ITEM	PART NO.	DESCRIPTION	QTY.	WEIGHT	NOTE NO.
1	MTC306503W	1030 Ringmount Weldment	3	31.09 LBS	
2	MT38430B7	3/4" X 30" GALV THREADED ROD GRADE B7	6	3.73 LBS	
3	GWL-06	3/4" GALV LOCK WASHER	12	0.04 LBS	
4	GN-06	3/4" GALV HEX NUT	12	0.12 LBS	
5	RK01	KICKER STANDOFF WELDMENT	3	12.71 LBS	
6	RK02	CONNECTION BRACKET	6	1.21 LBS	
7	RK36	KICKER ARM SUPPORT TUBE , 36"	3	16.02 LBS	
8	DCP10	SMALL CLAMP HALF	6	2.21 LBS	
9	MTC323704	Clamp Bar	6	2.37 LBS	
10	GB-0546A	5/8" X 4-3/4" GALV BOLT KIT A325	6	0.50 LBS	
11	GB-0520A	5/8" X 2" GALV BOLT KIT (A325)	12	0.26 LBS	
12	MT-381-8	5/8" X 8" GALV THREADED ROD	6	0.69 LBS	
13	GWF-05	5/8" GALV FLAT WASHER	12	0.06 LBS	
14	GWL-05	5/8" GALV LOCK WASHER	12	0.03 LBS	
15	GN-05	5/8" GALV HEX NUT	12	0.08 LBS	

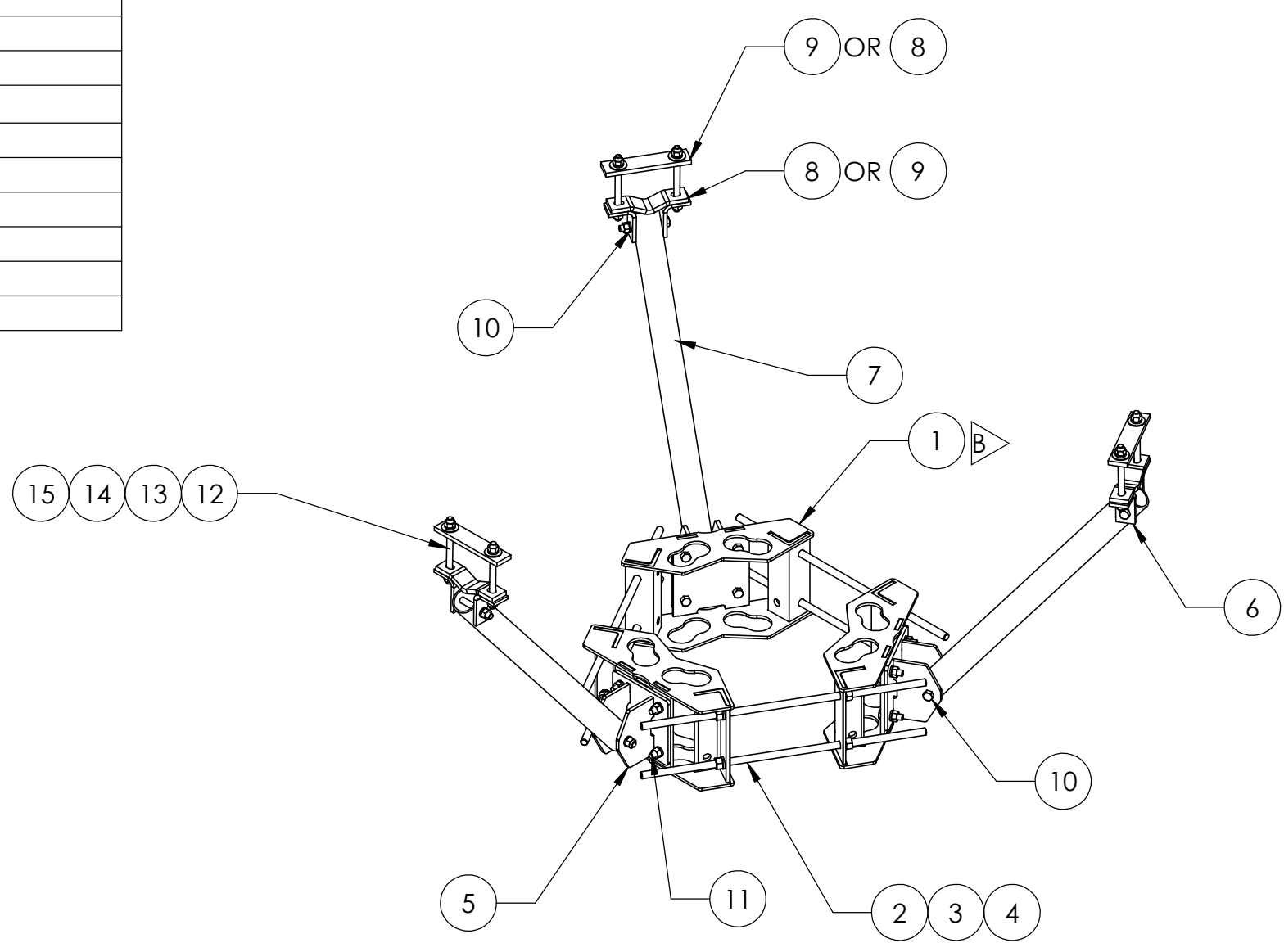

NOTES:
 1. ALL METRIC DIMENSIONS ARE IN BRACKETS.
 2. FITS MONOPOLES 10"-30"OD.

These drawings and specifications are the proprietary property of CommScope Inc. and may be used only for the specific purpose authorized in writing by CommScope Inc. ALL DIMENSIONS ARE IN INCHES U.O.S. TOLERANCES UNLESS OTHERWISE SPECIFIED: .X = ± .12 ANGLES ±2° .XX = ± .06 FRACTIONS ±1/32 .XXX = ± .03 REMOVE BURRS AND BREAK EDGES .005 DO NOT SCALE THIS PRINT		DRAWN BY: MSM CHECKED BY: TP DATE: 09/22/14 REVISION: B	SHEET: 2 of 3 SCALE: NTS MATERIAL: A36, A529, A500 FINISH: GALV A123 WEIGHT: 239.56 LBS	PART NUMBER: RK-36-3S DESCRIPTION: reinforcement Kit, 3-Sector, 36" Arm, 10-30 DRAWING TYPE: SHOP DRAWING COMMSCOPE® Hickory, NC 28602 U.S.A.
--	--	--	---	--

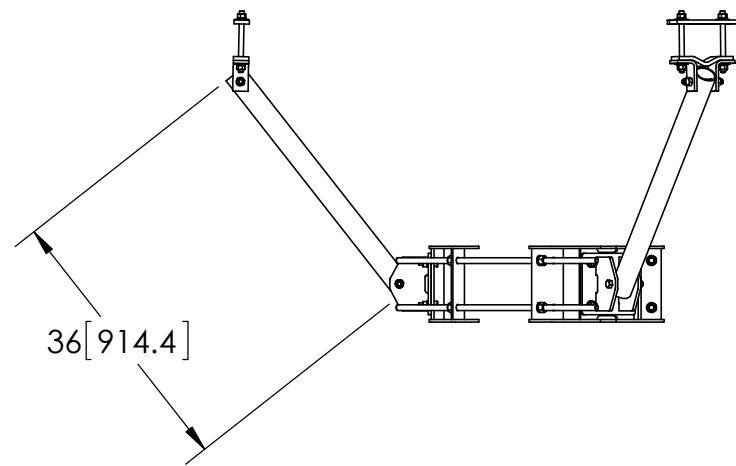
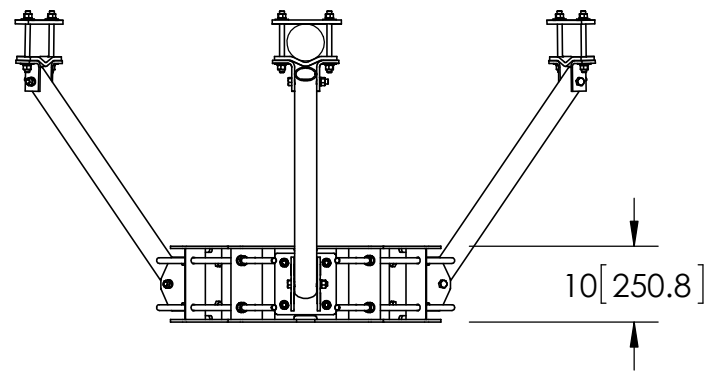
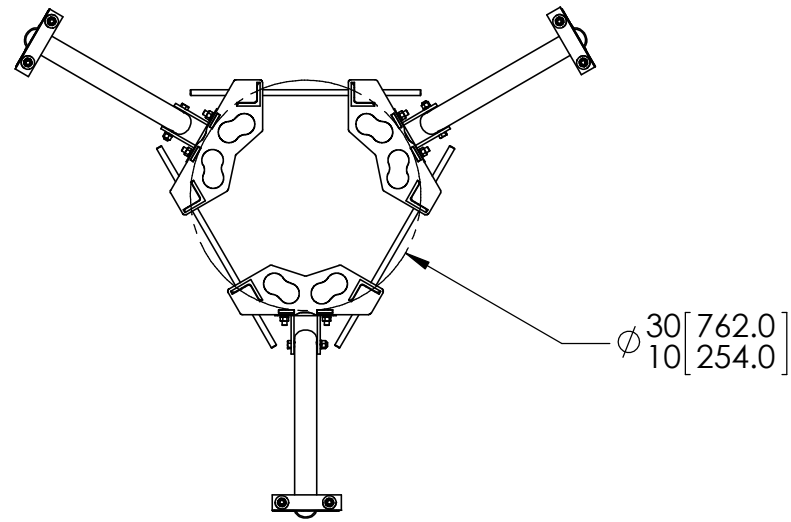

<p>These drawings and specifications are the proprietary property of CommScope Inc. and may be used only for the specific purpose authorized in writing by CommScope Inc.</p> <p>ALL DIMENSIONS ARE IN INCHES U.O.S. TOLERANCES UNLESS OTHERWISE SPECIFIED:</p> <p>.X = ± .12 ANGLES ±2° .XX = ± .06 FRACTIONS ±1/32 .XXX = ± .03</p> <p>REMOVE BURRS AND BREAK EDGES .005</p> <p>DO NOT SCALE THIS PRINT</p>	DRAWN BY: MSM	SHEET: 3 of 3	PART NUMBER: RK-36-3S
	CHECKED BY: TP	SCALE: NTS	DESCRIPTION: reinforcement Kit, 3-Sector, 36" Arm, 10-30
	DATE: 09/22/14	MATERIAL: A36, A529, A500	DRAWING TYPE: SHOP DRAWING
	REVISION: B	FINISH: GALV A123	<p>Hickory, NC 28602 U.S.A.</p>
	WEIGHT: 239.56 LBS		