

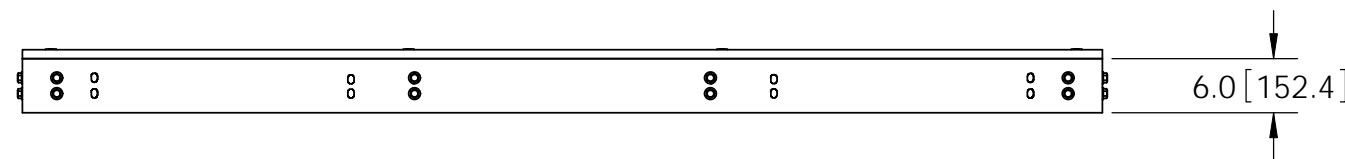

ITEM	PART NO.	DESCRIPTION	QTY.	WEIGHT
1	MTCPCC06.01	6' Platform Channel Center	4	46.23 LBS
2	EQP6C041001	10' Platform Channel Side	2	80.98 LBS
3	MTCP.01	6" Channel Adapter Angle	8	3.18 LBS
4	GB-05205	5/8" X 2" GALV BOLT KIT	32	0.12 LBS
5	GWF-05	5/8" GALV FLAT WASHER	64	0.04 LBS
6	GCM03	GRATING CLIP	24	0.40 LBS
7	MTC79020810.01	24" X 120" BAR GRATING	3	142.72 LBS

REVISIONS				
REV.	ZONE	DESCRIPTION	BY	DATE
A		INITIAL RELEASE	OGG	08/12/10

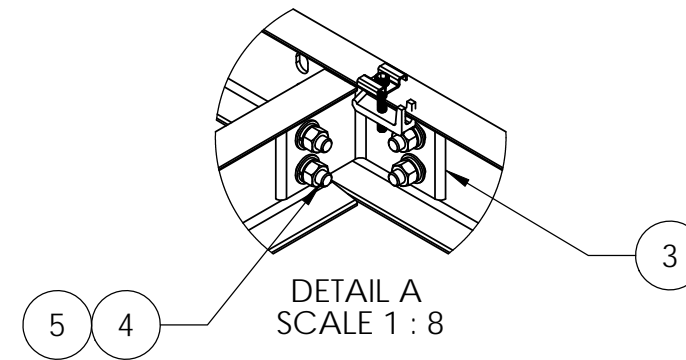
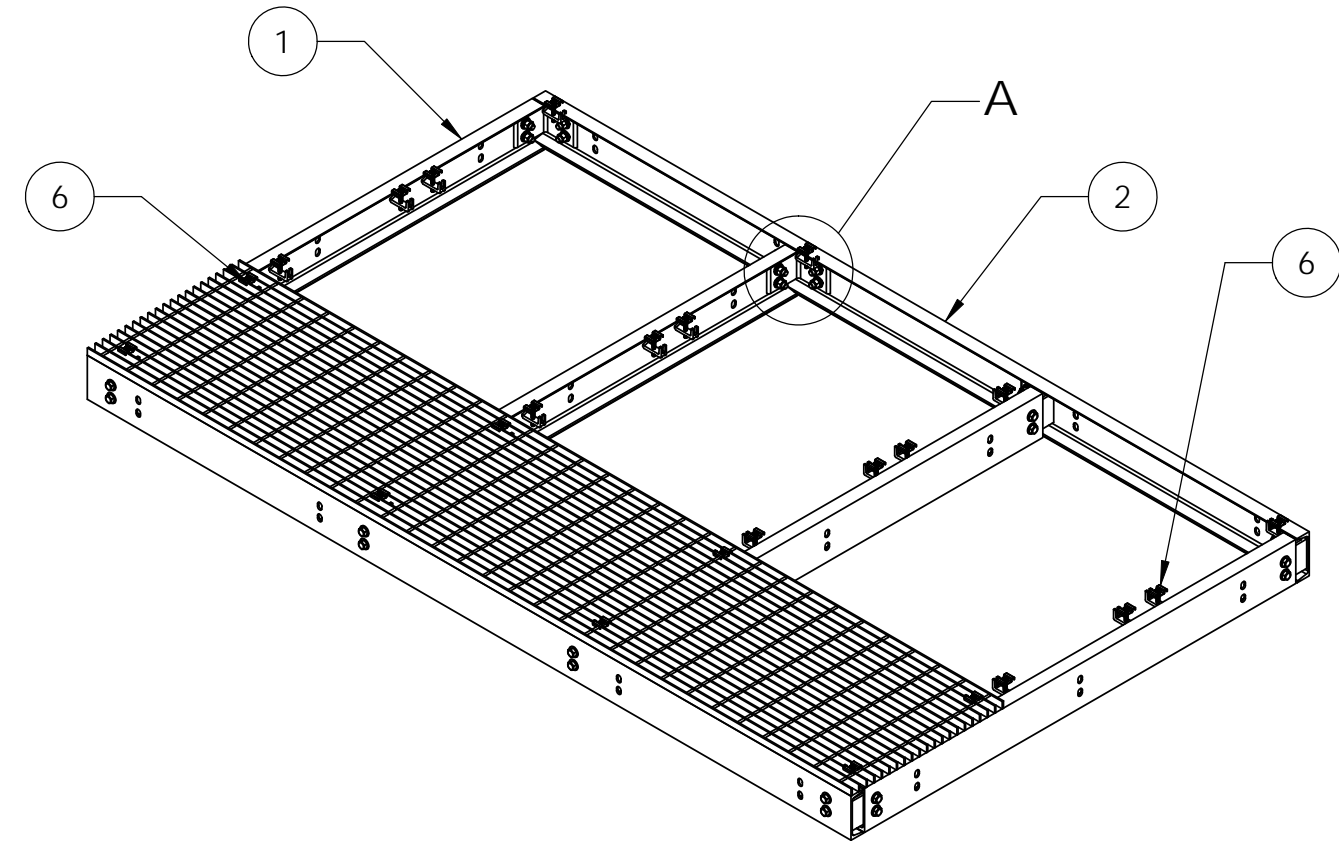
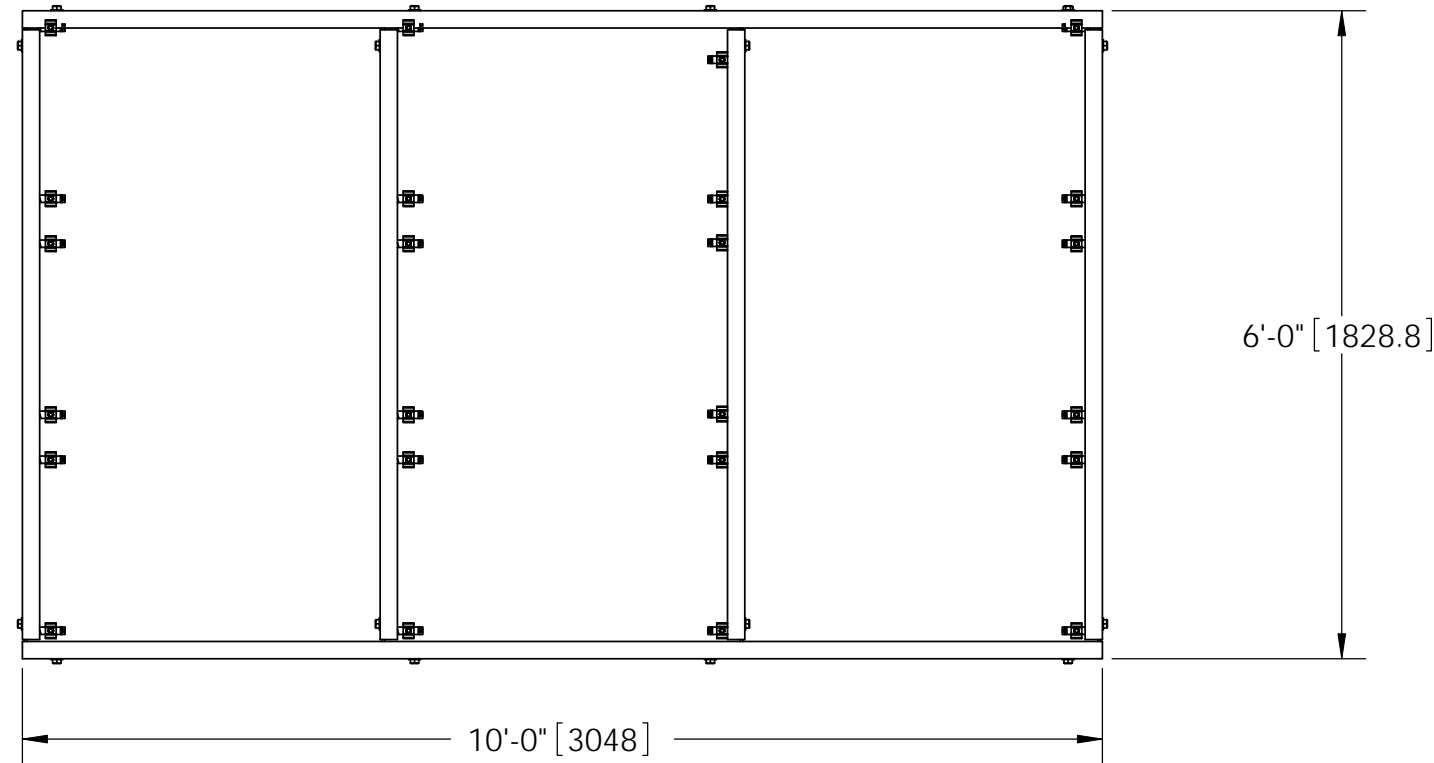

- NOTES:
- ALL METRIC DIMENSIONS ARE IN BRACKETS.
 - GRATING REMOVED FOR CLARITY.

<small>These drawings and specifications are the proprietary property of ANDREW CORPORATION and may be used only for the specific purpose authorized in writing by Andrew Corporation.</small> ALL DIMENSIONS ARE IN INCHES U.O.S. TOLERANCES UNLESS OTHERWISE SPECIFIED: .X = ± .12 ANGLES ±2° .XX = ± .06 FRACTIONS ±1/32 .XXX = ± .03 REMOVE BURRS AND BREAK EDGES .005	DRAWN BY: OGG	SHEET: 1 of 1	PART NUMBER: EQ-P6C0610-B
	CHECKED BY: TP	SCALE: NTS	DESCRIPTION: 6' X 10' Equipment Platform
	DATE: 08/12/10	MATERIAL: A36, A568	DRAWING TYPE: ASSEMBLY DRAWING
	REVISION: A	FINISH: GALV A123	WEIGHT: 823.67 LBS
DO NOT SCALE THIS PRINT			 WESTCHESTER, IL. 60154 U.S.A.