

ITEM	PART NO.	DESCRIPTION	QTY.	WEIGHT
1	EQ-P6C0416-B	4' X 16' Equipment Platform	1	933.14 LBS
2	EQ-P-AL	ADJUSTABLE LEG KIT FOR EQ-P SERIES	6	56 LBS

REVISIONS				
REV.	ZONE	DESCRIPTION	BY	DATE
A		INITIAL RELEASE	DRR	03/17/11
B		REVISED WEIGHTS	DRR	05/22/12

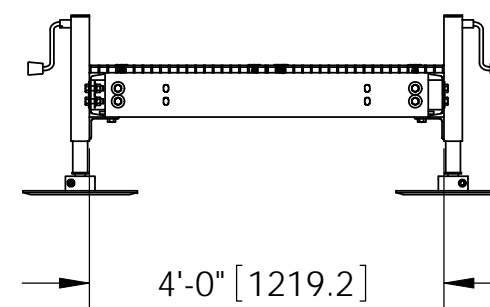
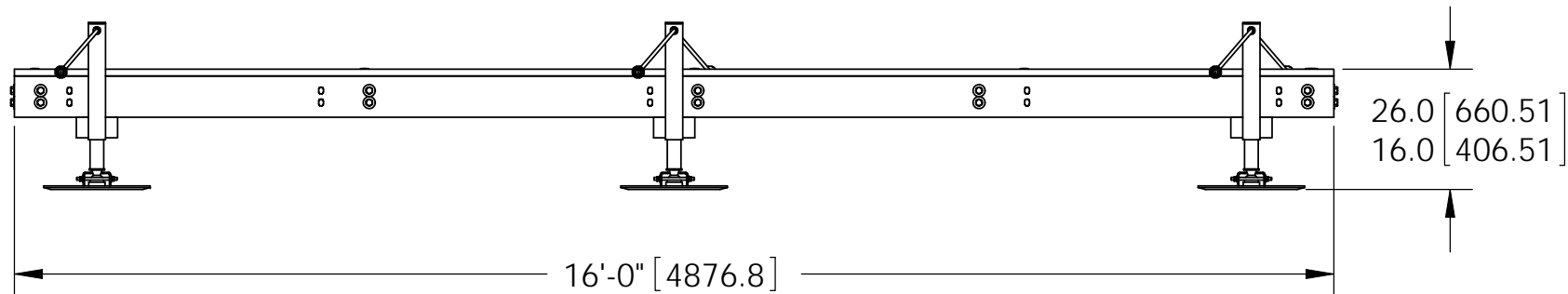
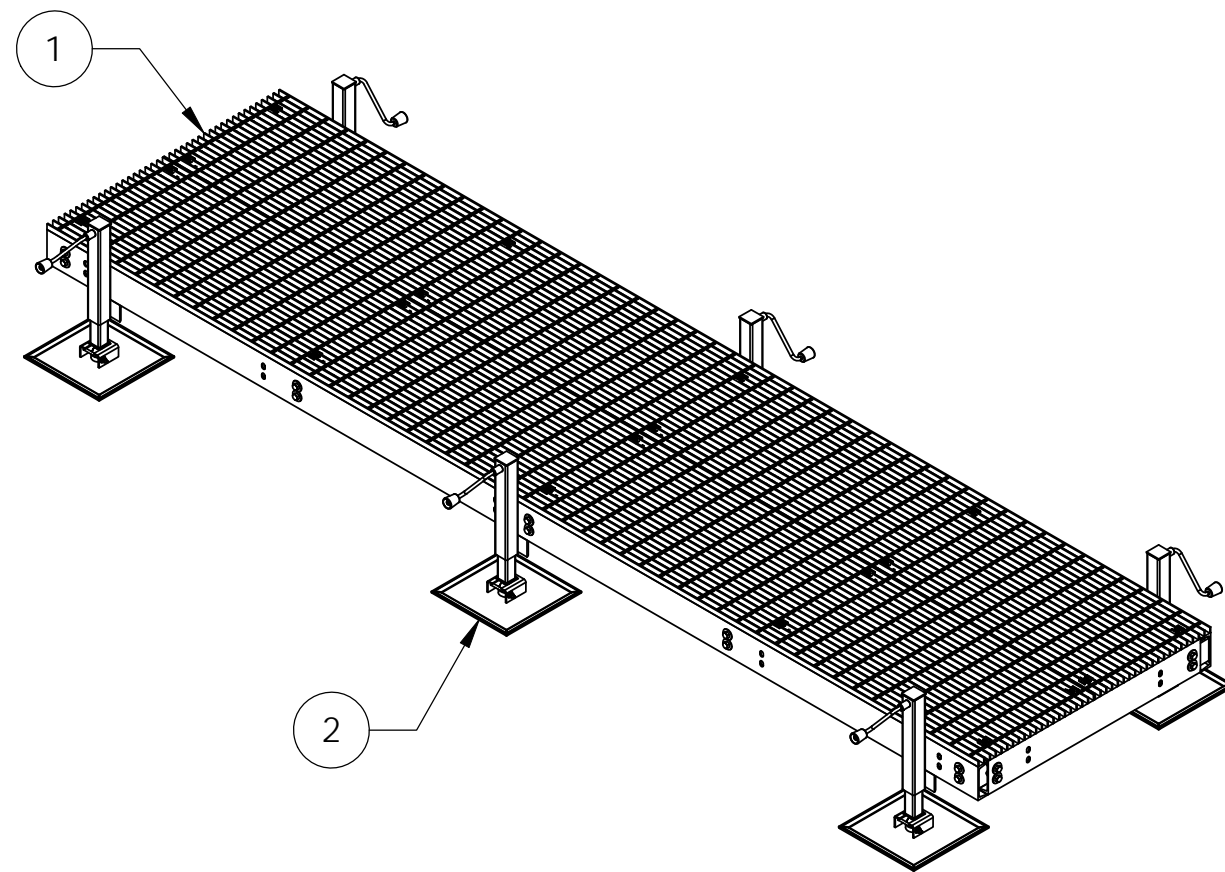
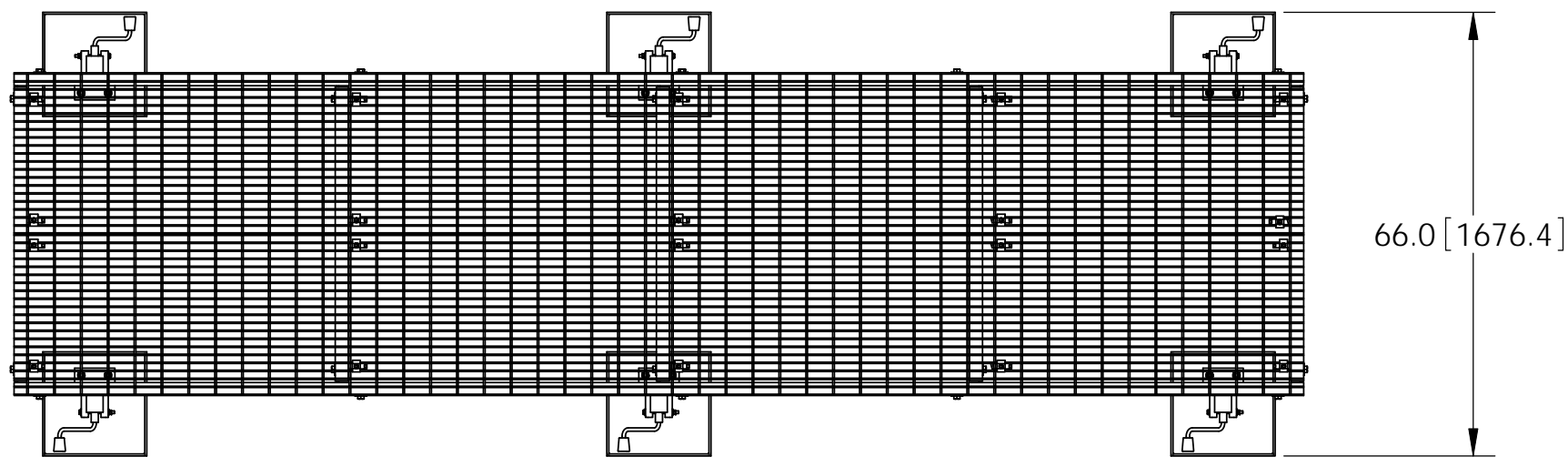

NOTES:
1. ALL METRIC DIMENSIONS ARE IN BRACKETS.

These drawings and specifications are the proprietary property of ANDREW CORPORATION and may be used only for the specific purpose authorized in writing by Andrew Corporation.

ALL DIMENSIONS ARE IN INCHES U.O.S.
TOLERANCES UNLESS OTHERWISE SPECIFIED:
.X = ± .12 ANGLES ±2°
.XX = ± .06 FRACTIONS ±1/32
.XXX = ± .031

REMOVE BURRS AND BREAK EDGES .005

DO NOT SCALE THIS PRINT

DRAWN BY: OGG	SHEET: 1 of 1	PART NUMBER: EQ-P6C0416-AL
CHECKED BY: TP	SCALE: NTS	DESCRIPTION: 4' X 16' Equipment Platform, 6 AL
DATE: 02/17/10	MATERIAL: A36, A568	DRAWING TYPE: ASSEMBLY DRAWING
REVISION: B	FINISH: GALV A123	
	WEIGHT: 1269.14 LBS	

