

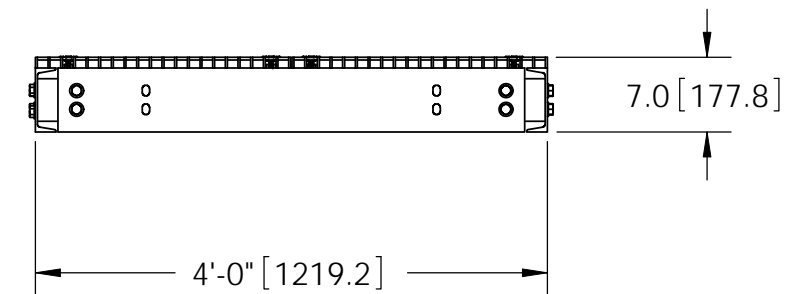

ITEM	PART NO.	DESCRIPTION	QTY.	WEIGHT
1	EQP6C041001	10' Platform Channel Side	2	80.98 LBS
2	EQP6C040801	4' Platform Channel Center	4	29.80 LBS
3	MTC9170.09	24" X 120" BAR GRATING	2	142.72 LBS
4	MTCP.01	6" Channel Adapter Angle	8	3.18 LBS
5	GB-05205	5/8" X 2" GALV BOLT KIT	32	0.16 LBS
6	GWF-05	5/8" GALV FLAT WASHER	64	0.02 LBS
7	GCM03	GRATING CLIP	16	0.40 LBS

REVISIONS				
REV.	ZONE	DESCRIPTION	BY	DATE
A		INITIAL RELEASE	OGG	02/17/10

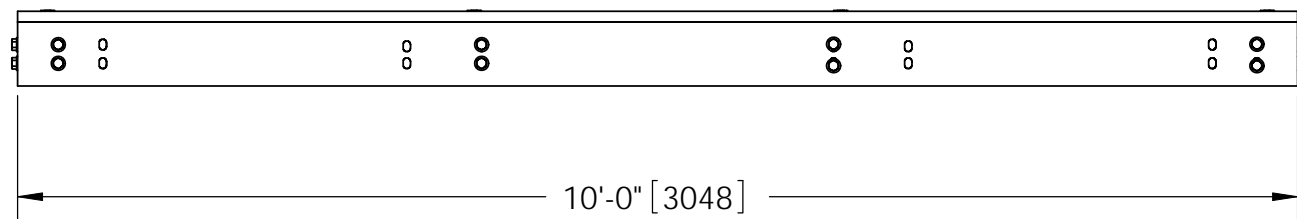
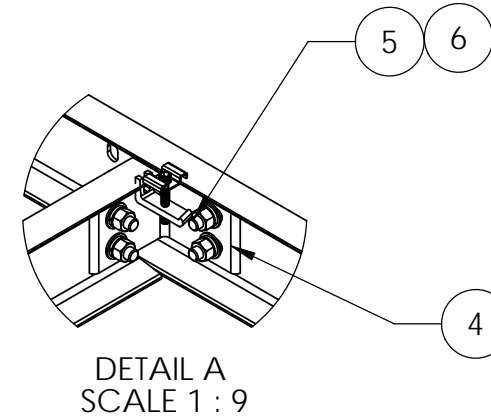
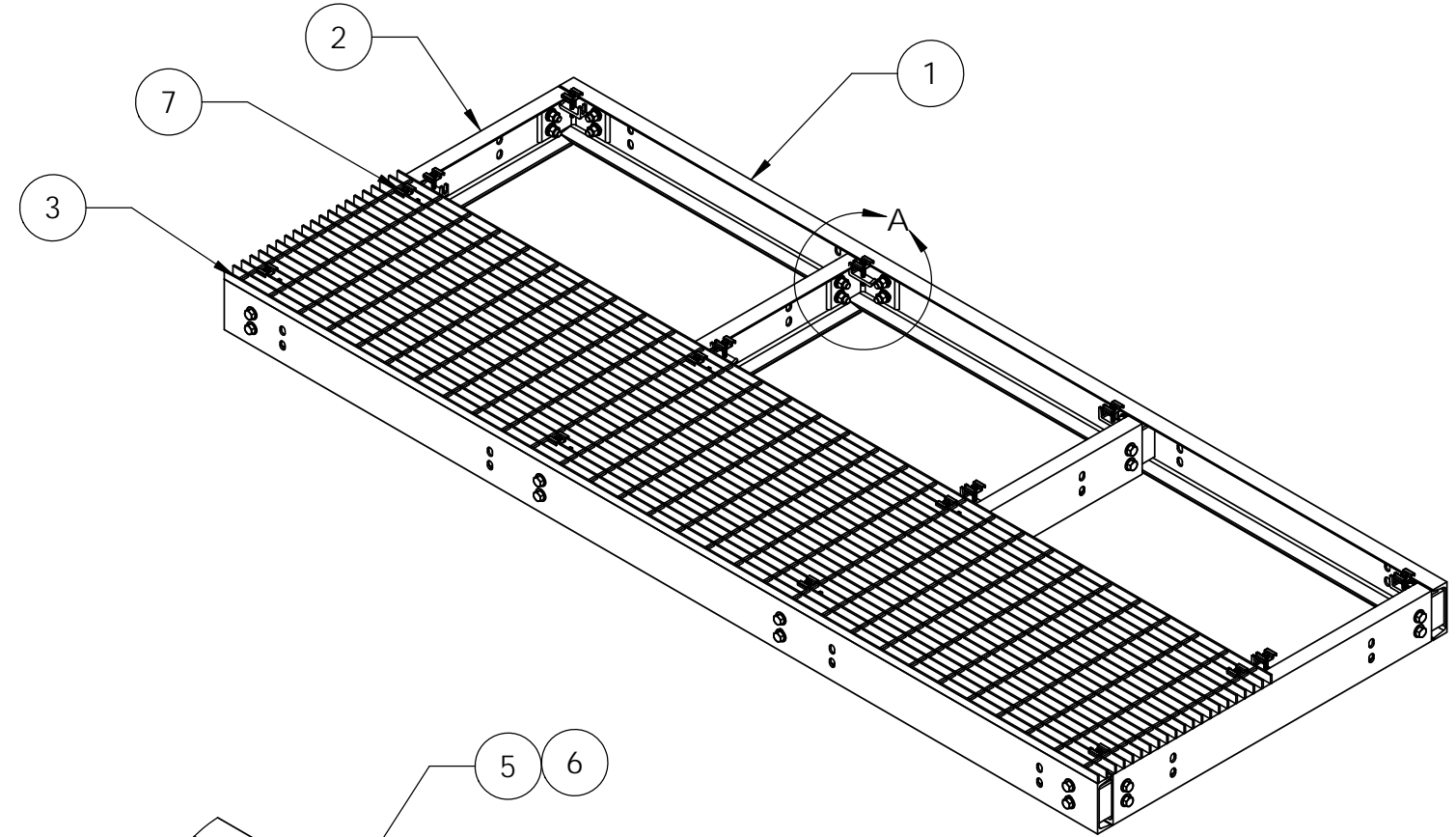
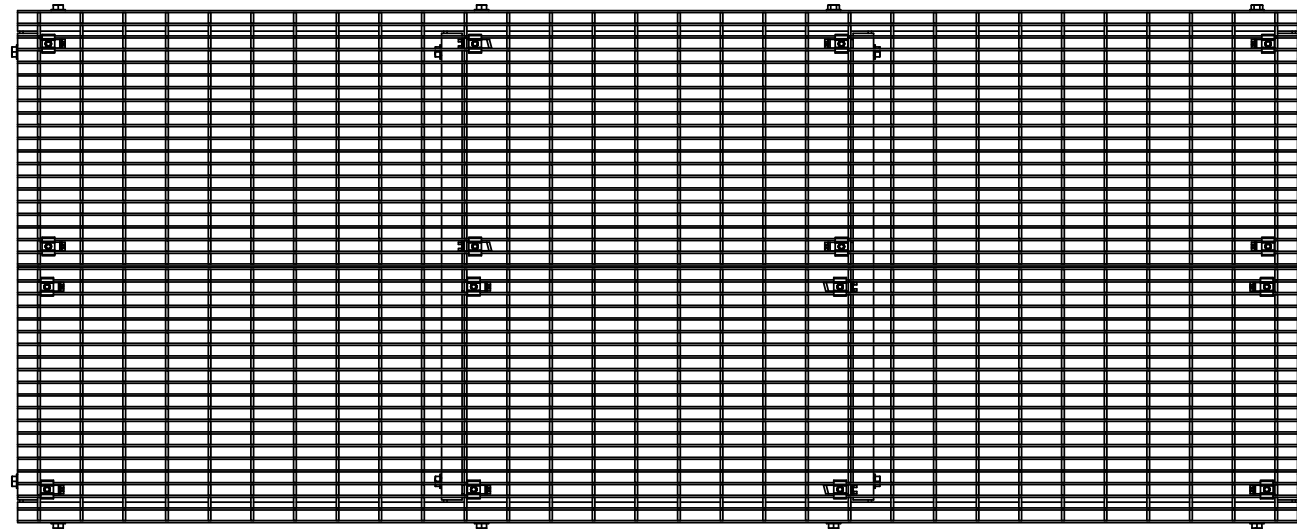

NOTES:

- ALL METRIC DIMENSIONS ARE IN BRACKETS.
- STAMP PART IDENTIFICATION NUMBER.
- GRATING REMOVED FOR CLARITY.

<small>These drawings and specifications are the proprietary property of ANDREW CORPORATION and may be used only for the specific purpose authorized in writing by Andrew Corporation.</small> ALL DIMENSIONS ARE IN INCHES U.O.S. TOLERANCES UNLESS OTHERWISE SPECIFIED: .X = ± .12 ANGLES ±2° .XX = ± .06 FRACTIONS ±1/32 .XXX = ± .03 REMOVE BURRS AND BREAK EDGES .005 DO NOT SCALE THIS PRINT	DRAWN BY: OGG	SHEET: 1 of 1	PART NUMBER: EQ-P6C0410-B
	CHECKED BY: TP	SCALE: NTS	DESCRIPTION: 4' X 10' Equipment Platform
	DATE: 02/17/10	MATERIAL: A36, A568	DRAWING TYPE: ASSEMBLY DRAWING
	REVISION: A	FINISH: GALV A123 WEIGHT: 616.75 LBS	 WESTCHESTER, IL. 60154 U.S.A.