

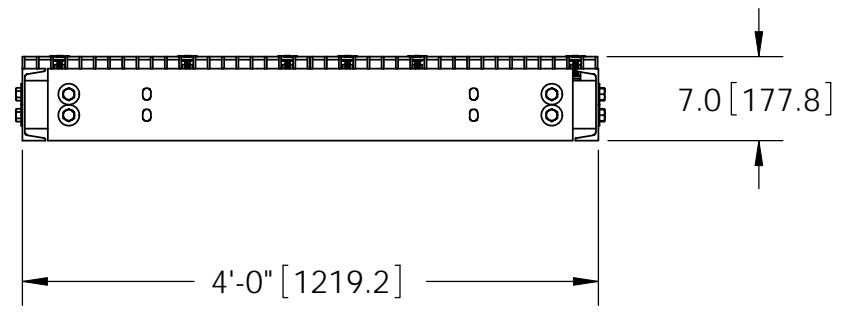

ITEM	PART NO.	DESCRIPTION	QTY.	WEIGHT
1	EQP6C040803	8' Platform Channel Side	2	64.68 LBS
2	EQP6C040801	4' Platform Channel Center	4	29.80 LBS
3	MT-C9003.01	24" X 96" BAR GRATING	2	115.46 LBS
4	MTCP.01	6" Channel Adapter Angle	8	3.18 LBS
5	GB-05205	5/8" X 2" GALV BOLT KIT	32	0.27 LBS
6	GWF-05	5/8" GALV FLAT WASHER	64	0.06 LBS
7	GCM03	GRATING CLIP	12	0.39 LBS

REVISIONS				
REV.	ZONE	DESCRIPTION	BY	DATE
A		INITIAL RELEASE	MSM	02/17/10
B		ADD CENTER BRACE AND ANGLE	MSM	05/18/12

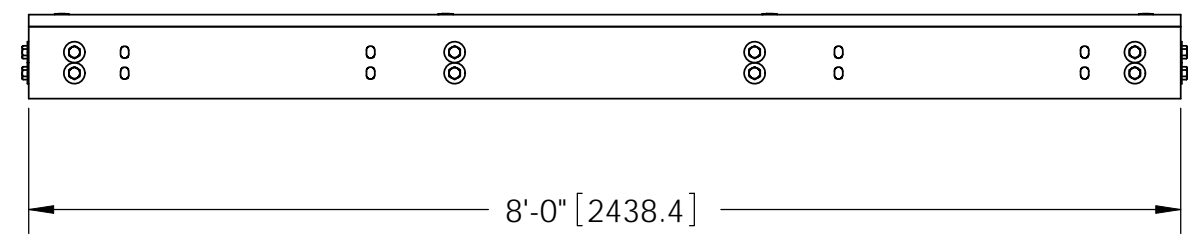
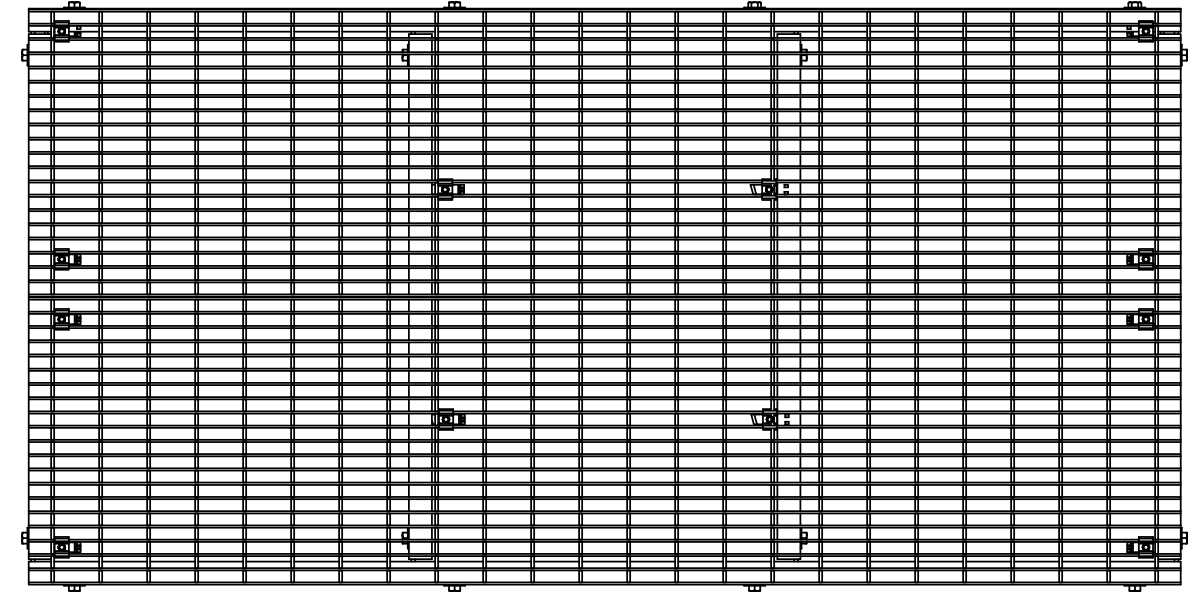
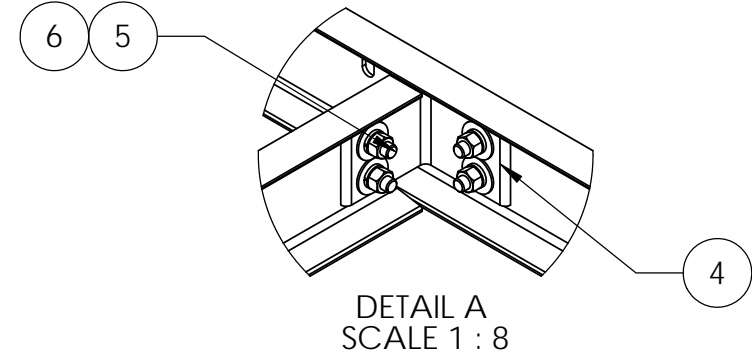
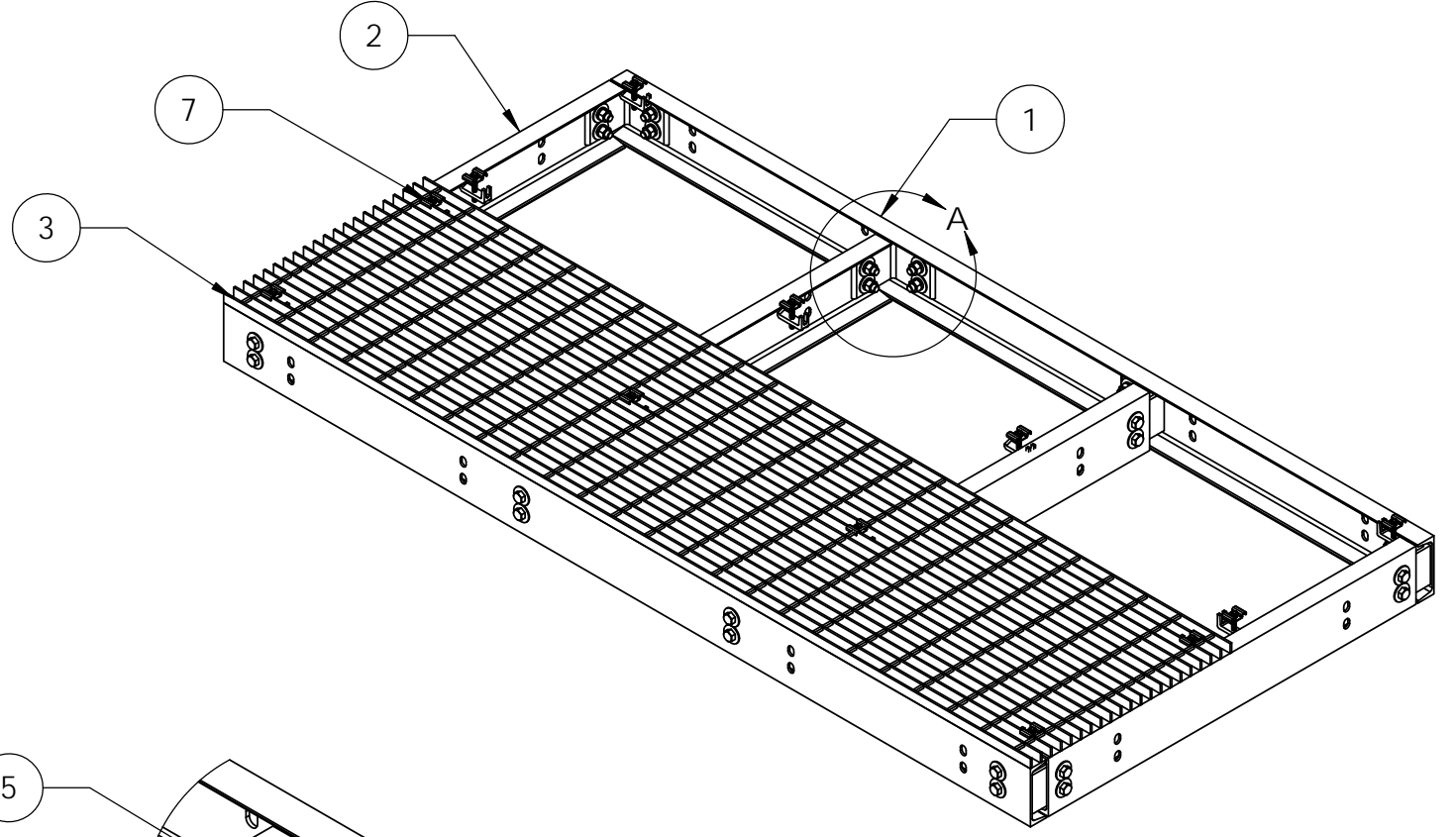

NOTES:
 1. ALL METRIC DIMENSIONS ARE IN BRACKETS.
 2. STAMP PART IDENTIFICATION NUMBER.
 3. GRATING REMOVED FOR CLARITY.

<small>These drawings and specifications are the proprietary property of ANDREW CORPORATION and may be used only for the specific purpose authorized in writing by Andrew Corporation.</small> <small>ALL DIMENSIONS ARE IN INCHES U.O.S.</small> <small>TOLERANCES UNLESS OTHERWISE SPECIFIED:</small> .X = ± .12 ANGLES ±2° .XX = ± .06 FRACTIONS ±1/32 .XXX = ± .03 <small>REMOVE BURRS AND BREAK EDGES .005</small> DO NOT SCALE THIS PRINT	<small>DRAWN BY:</small> MSM	<small>SHEET:</small> 1 of 1	<small>PART NUMBER:</small> EQ-P6C0408-B
	<small>CHECKED BY:</small> TP	<small>SCALE:</small> NTS	<small>DESCRIPTION:</small> 4' X 8' Equipment Platform
	<small>DATE:</small> 02/18/10	<small>MATERIAL:</small> A36, A568	<small>DRAWING TYPE:</small> ASSEMBLY DRAWING
	<small>REVISION:</small> B	<small>FINISH:</small> GALV A123 <small>WEIGHT:</small> 525.17 LBS	 WESTCHESTER, IL. 60154 U.S.A.