

ITEM	PART NO.	DESCRIPTION	QTY.	WEIGHT
1	EQP4C040601	6' Side , 4" Channel	2	31.98 LBS
2	EQP4C040402	Center Channel 4' Platform	3	19.87 LBS
3	EQP4C01	4" Channel Platform Angle	6	2.37 LBS
4	MTC9049.12	24" X 72" BAR GRATING	2	85.63 LBS
5	GCM03	GRATING CLIP	12	0.40 LBS
6	GB-04165	1/2" X 1-3/4" GALV BOLT KIT	24	0.13 LBS
7	GWF-04	1/2" GALV FLAT WASHER	48	0.02 LBS

REVISIONS				
REV.	ZONE	DESCRIPTION	BY	DATE
A		INITIAL RELEASE	MSM	09/27/10

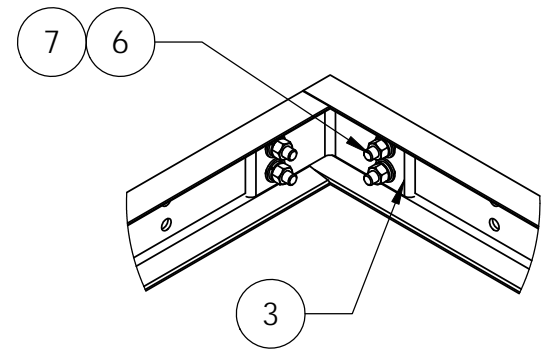

DETAIL A
SCALE 1 : 8

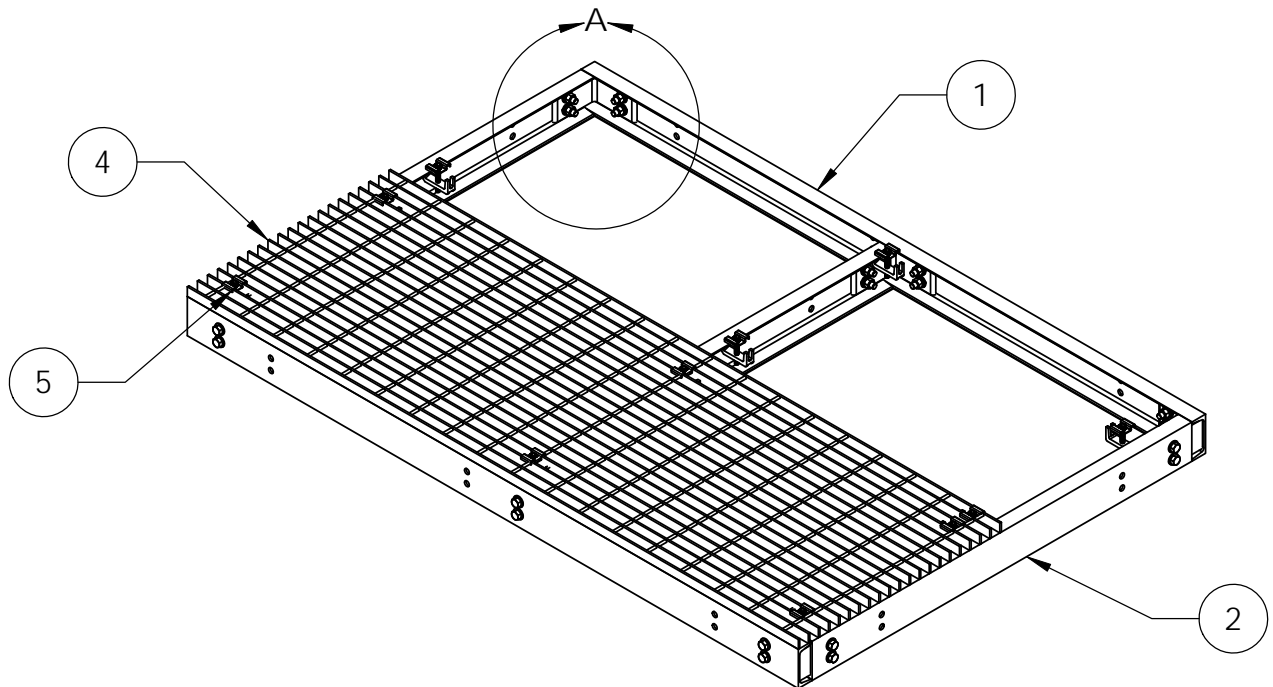
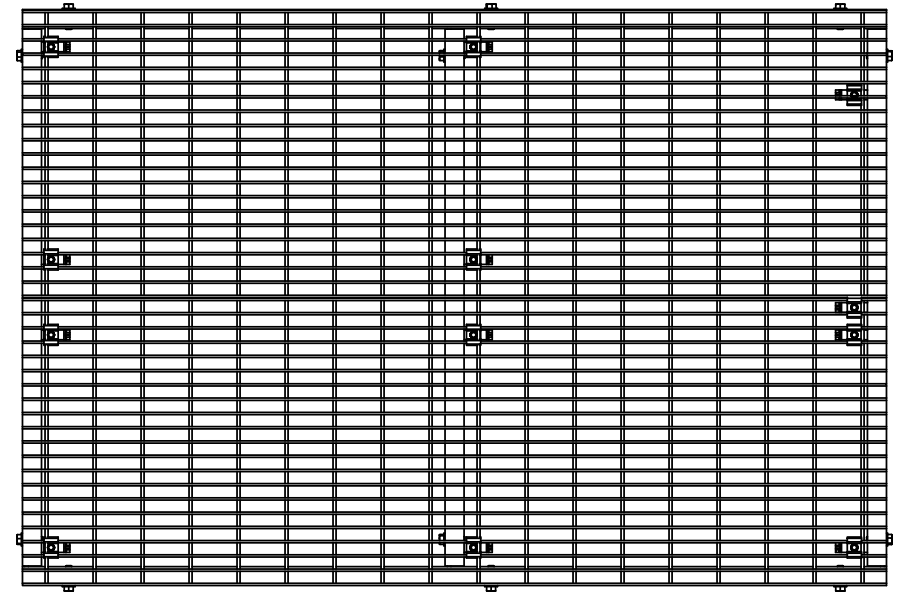
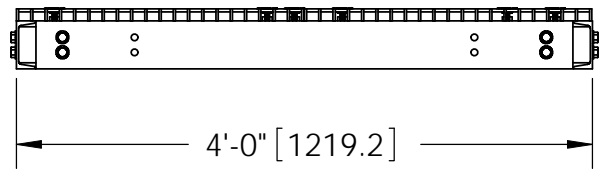
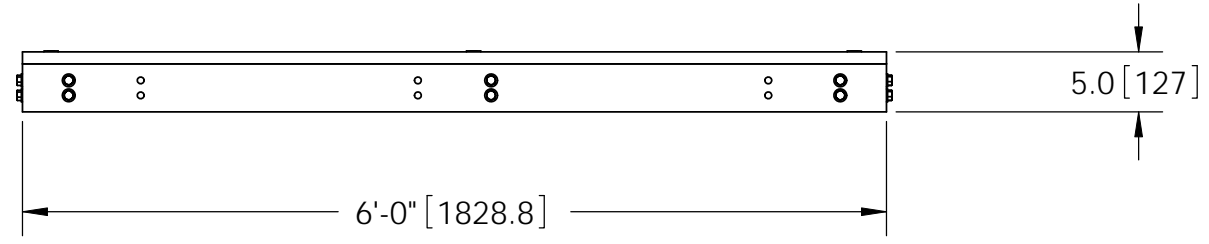

NOTES:
1. ALL METRIC DIMENSIONS ARE IN BRACKETS.

<small>These drawings and specifications are the proprietary property of ANDREW CORPORATION and may be used only for the specific purpose authorized in writing by Andrew Corporation.</small> ALL DIMENSIONS ARE IN INCHES U.O.S. TOLERANCES UNLESS OTHERWISE SPECIFIED: .X = ± .12 ANGLES ±2° .XX = ± .06 FRACTIONS ±1/32 .XXX = ± .03 REMOVE BURRS AND BREAK EDGES .005 DO NOT SCALE THIS PRINT	DRAWN BY: MSM	SHEET: 1 of 1	PART NUMBER: EQ-P4C0406-B
	CHECKED BY: TP	SCALE: NTS	DESCRIPTION: 4' x 6' Equipment Platform Base
	DATE: 09/27/10	MATERIAL: A36, A568	DRAWING TYPE: ASSEMBLY DRAWING
	REVISION: A	FINISH: GALV A123	 WESTCHESTER, IL. 60154 U.S.A.
	WEIGHT: 319.53 LBS		