

ITEM	PART NO.	DESCRIPTION	QTY.	WEIGHT
1	EQ-P1016-B	10' X 16' Equipment Platform	1	2205.57 LBS
2	EQ-P-AL	ADJUSTABLE LEG KIT FOR EQ-P SERIES	6	56 LBS

REVISIONS				
REV.	ZONE	DESCRIPTION	BY	DATE
A		INITIAL RELEASE	MSM	04/03/12

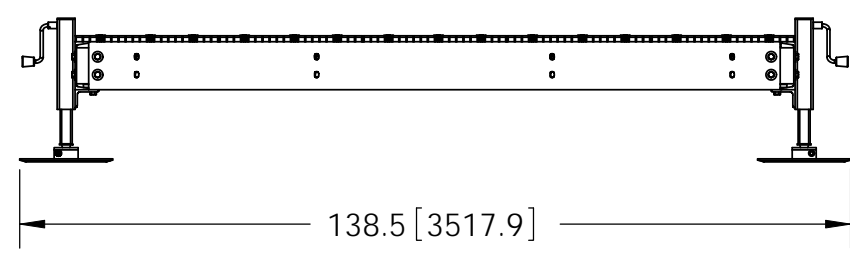
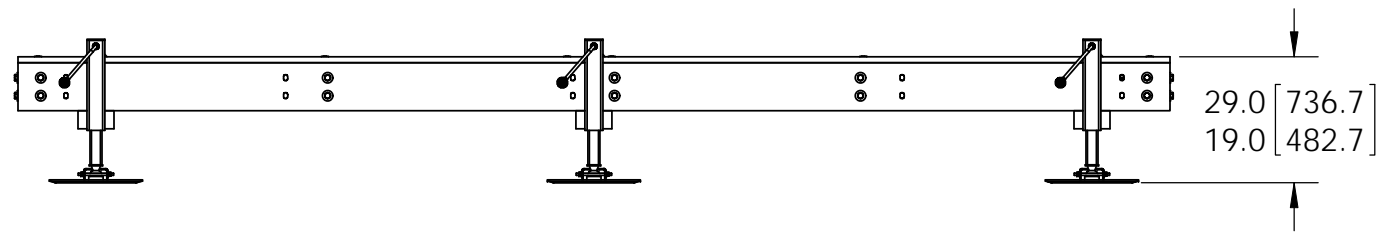
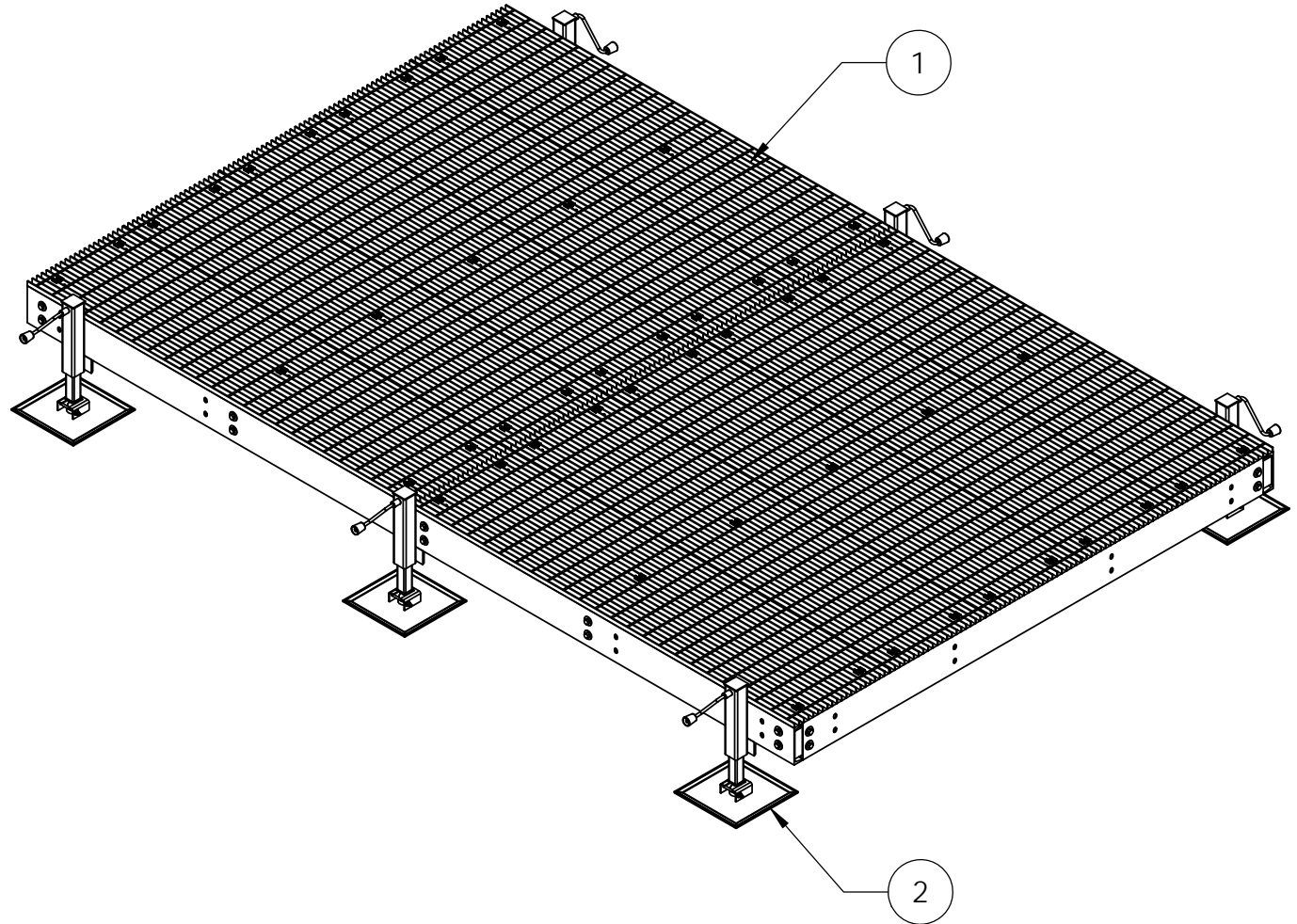
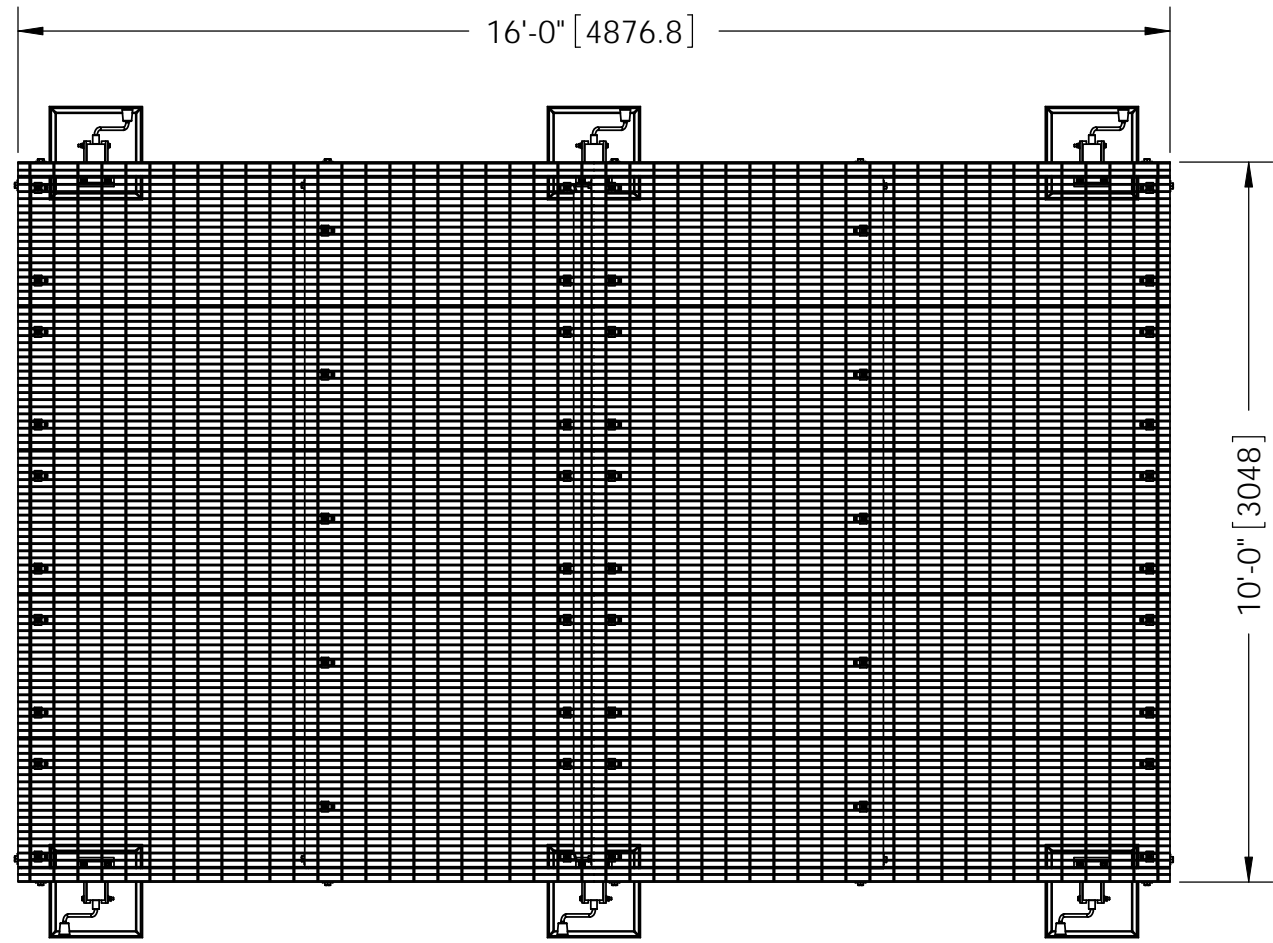

NOTES:  
1. ALL METRIC DIMENSIONS ARE IN BRACKETS.

These drawings and specifications are the proprietary property of CommScope Inc. and may be used only for the specific purpose authorized in writing by CommScope Inc.  ALL DIMENSIONS ARE IN INCHES U.O.S. TOLERANCES UNLESS OTHERWISE SPECIFIED: .X = ± .12      ANGLES ±2° .XX = ± .06      FRACTIONS ±1/32 .XXX = ± .03  REMOVE BURRS AND BREAK EDGES .005  DO NOT SCALE THIS PRINT	DRAWN BY: MSM	SHEET: 1 of 1	PART NUMBER: EQ-P1016-AL
	CHECKED BY: TP	SCALE: NTS	DESCRIPTION: 10' X 16' Equipment Platform w/ 6 AL
	DATE: 04/03/12	MATERIAL: A36, A529, A568	DRAWING TYPE: ASSEMBLY DRAWING
	REVISION: A	FINISH: GLAV A123	 WESTCHESTER, IL. 60154 U.S.A.
		WEIGHT: 2541.57 LBS	