

Next Generation Frame (NGF)

72-Position Fiber Termination Block (FTB)

User Manual

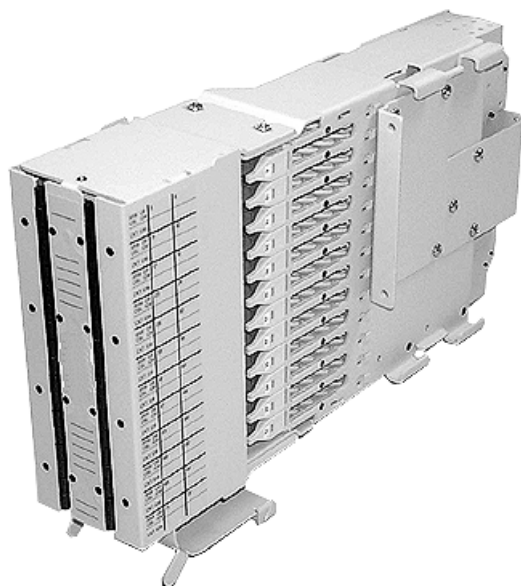

ADCP-90-271
Rev B, April 2018

COPYRIGHT

© 2018, CommScope Inc.
All Rights Reserved

REVISION HISTORY

ISSUE	DATE	REASON FOR CHANGE
1	7/2014	Original.
Rev B	April 2018	Updated to CommScope format.

TRADEMARK INFORMATION

CommScope and CommScope (logo), are trademarks.
Telcordia is a registered trademark of Telcordia Technologies, Inc.
GORE is a registered trademark of W. L. Gore & Associates, Inc.

DISCLAIMER OF LIABILITY

Contents herein are current as of the date of publication. TE Connectivity reserves the right to change the contents without prior notice. **In no event shall TE Connectivity be liable for any damages resulting from loss of data, loss of use, or loss of profits and TE Connectivity further disclaims any and all liability for indirect, incidental, special, consequential or other similar damages. This disclaimer of liability applies to all products, publications and services during and after the warranty period.**

This publication may be verified at any time online by contacting TE Connectivity's Technical Assistance Center using the following URL: <http://www.commscope.com/SupportCenter>



TABLE OF CONTENTS

Content	Page
ABOUT THIS MANUAL	v
RELATED PUBLICATIONS	v
ADMONISHMENTS	vi
GENERAL SAFETY PRECAUTIONS	vi
LIST OF ACRONYMS	vi
1 OVERVIEW AND DESCRIPTION	1
1.1 Description	1
1.1.1 FTB Primary Function	1
1.1.2 FTB Primary Components	2
1.1.3 Options That Affect Installation	4
1.1.4 Accessories	5
1.2 Applications	5
1.2.1 Interconnect Application	5
1.2.2 Cross-Connect Application	6
1.3 Specifications	7
2 UNPACKING, INSPECTION, AND ASSEMBLY	7
2.1 Unpacking and Inspecting the Product	7
2.2 Adapter Pack Installation	8
3 IFC OR OSP CABLE INSTALLATION	9
3.1 Preparing Cable for Installation	10
3.2 Clamping Cable to FTB	11
3.3 Routing and Connecting Cable Fibers Within FTB	14
4 FTB INSTALLATION	17
4.1 Mounting FTB On Rack	17
4.2 Securing IFC or OSP Cable to Rack	20
5 FOT EQUIPMENT PATCH CORD INSTALLATION	22
5.1 Terminating Patch Cord at FTB	22
5.2 Installing FOT Equipment Patch Cords—Overhead Without FOTSB	24
5.3 Installing FOT Equipment Patch Cords—Overhead With FOTSB	26
5.4 Installing FOT Equipment Patch Cords—Underfloor Without FOTSB	28
5.5 Installing FOT Equipment Patch Cords—Underfloor With FOTSB	30
6 CUSTOMER INFORMATION AND ASSISTANCE	32

TABLE OF CONTENTS

Content	Page
---------	------

ABOUT THIS MANUAL

This user manual describes the CommScope 72 Position Fiber Termination Block (FTB) and provides all information required to install and operate this product. CommScope also makes a 96 & 144 Position FTB documented in another user manual. This manual contains:

- A description of basic FTB components and terminology, typical FTB applications, and typical FTB accessories;
- Procedures for installing the FTB on any of the Next Generation Frame (NGF) racks;
- Procedures for terminating connectorized Outside Plant (OSP) cables, Intra-Facility Cables (IFC), or Fiber Optic Terminal (FOT) equipment patch cords at the FTB.

Installation instructions for the various NGF racks including the Fiber Main Distribution Frame (FMDF), the Front Facing Fiber Main Distribution Frame (F3MDF), and the Slim Rack Fiber Distribution Frame are provided in other publications (see “Related Publications,” below).

RELATED PUBLICATIONS

Listed below are related manuals and their publication numbers. Copies of these publications can be ordered by contacting the CommScope Technical Assistance Center using the following URL:

<http://www.commscope.com/SupportCenter>

Title/Description	ADCP Number
<p>Next Generation Frame Fiber Main Distributing Frame User Manual Provides a complete description of the FMDF and procedures for installing the FMDF rack, the FTB, and the FCB.</p>	90-273
<p>Next Generation Frame Slim Rack Fiber Distributing Frame User Manual Provides a complete description of the slim rack frame and procedures for installing the FMDF rack, the FTB, and the FCB.</p>	90-272
<p>Next Generation Frame 96 & 144 Position Fiber Termination Block User Manual Provides instructions for installing the FCB in the NGF rack.</p>	90-287
<p>Next Generation Frame Fiber Combination Block (FCB) User Manual Provides instructions for installing the FCB in the NGF rack.</p>	90-279
<p>Next Generation Frame Fiber Optic Terminal Storage Bay (FOTSB) User Manual Provides instructions for installing the FOTSB with the FMDF rack.</p>	90-270

ADMONISHMENTS

Important safety admonishments are used throughout this manual to warn of possible hazards to persons or equipment. An admonishment identifies a possible hazard and then explains what may happen if the hazard is not avoided. The admonishments — in the form of Dangers, Warnings, and Cautions — must be followed at all times. These warnings are flagged by use of the triangular alert icon (seen below), and are listed in descending order of severity of injury or damage and likelihood of occurrence.



Danger: *Danger is used to indicate the presence of a hazard that **will** cause severe personal injury, death, or substantial property damage if the hazard is not avoided.*



Warning: *Warning is used to indicate the presence of a hazard that **can** cause severe personal injury, death, or substantial property damage if the hazard is not avoided.*



Caution: *Caution is used to indicate the presence of a hazard that **will** or **can** cause minor personal injury or property damage if the hazard is not avoided.*

GENERAL SAFETY PRECAUTIONS



Danger: *Infrared radiation is invisible and can seriously damage the retina of the eye. Do not look into the ends of any optical fiber. Do not look directly into the optical adapters of the adapter packs. Exposure to invisible laser radiation may result. An optical power meter should be used to verify active fibers. A protective cap or hood **MUST** be immediately placed over any radiating adapter or optical fiber connector to avoid the potential of dangerous amounts of radiation exposure. This practice also prevents dirt particles from entering the adapter or connector.*

LIST OF ACRONYMS

The following acronyms are used in this manual:

FCB	Fiber Combination Block
FMDF	Fiber Main Distributing Frame
FOT	Fiber Optic Terminal
FOTSB	Fiber Optic Terminal Storage Bay
FTB	Fiber Termination Block
F3MDF	Front Facing Fiber Main Distributing Frame
IFC	Intra-facility Fiber Cable
NGF	Next Generation Frame
OSP	Outside Plant
VAM	Value Added Module

1 OVERVIEW AND DESCRIPTION

This section provides a complete description of the 72 Position FTB, and explains the basic applications for the FTB. This section also provides specifications.

1.1 Description

1.1.1 FTB Primary Function

The Fiber Termination Block (FTB), shown in [Figure 1](#), is used in conjunction with an NGF rack (FMDF, F3MDF, or Slim Rack) to provide a point for terminating connectorized fiber optic cables and for interconnecting or cross-connecting the terminated circuits using fiber optic patch cords.

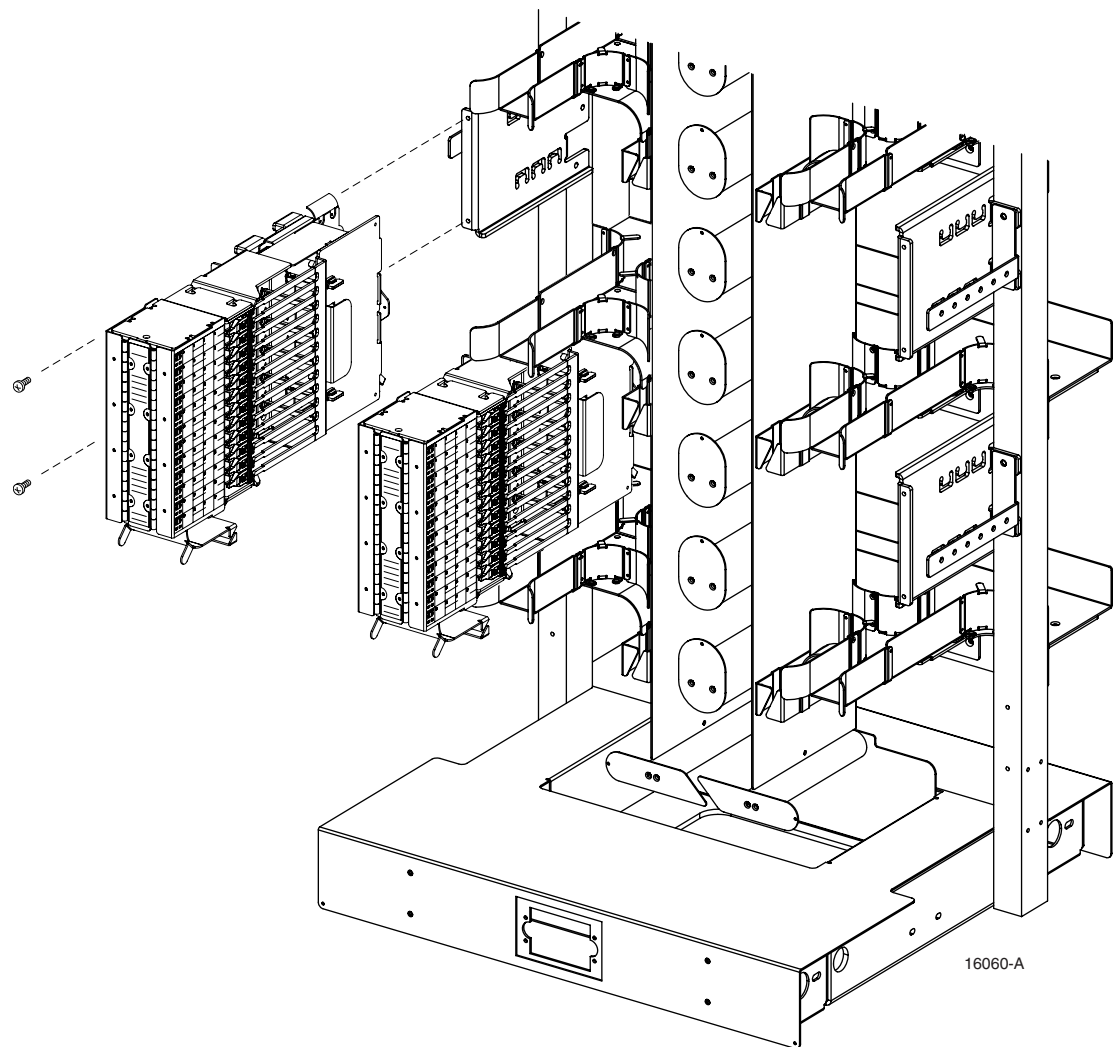

Figure 1. Fiber Termination Block Mounted on Frame

Connectorized OSP and IFC cables and FOT equipment patch cords terminate at the rear of the FTB. Cross-connect or interconnect patch cords connect to the front of the FTB. The FTB mounts on the NGF rack, which provides both support for the FTB and cable management functions. The FTB has a left or right orientation for installation on either the left or right side of the rack (as viewed from the front). In addition, the FTB also has a top or bottom cable exit orientation.

1.1.2 FTB Primary Components

The FTB, shown in [Figure 2](#), consists of a sheet metal chassis that houses rows of sliding adapter packs and the necessary cable management for routing the fiber optic cables within the chassis. The chassis portion of the FTB accepts the sliding adapter packs which may contain two, four, six, or eight adapters each depending on the adapter type. The adapter packs are available with SC, FC, ST, and E-2000 adapters that provide 48 or 72 terminations per FTB. The FTB will also accommodate several types of Mini Value Added Modules (Mini VAMs) which can be mounted in place of the adapter packs. The Mini VAMS provide a means for incorporating optical splitters or wave division multiplexers into the FTB.

The FTB chassis includes a removable side cover and two hinged front covers. Removing the side cover provides access to the rear cable management area and to the rear side of the adapter packs (see [Figure 2](#)). The rear cable management area includes features for clamping and routing OSP/IFC cables and a spool for storing excess fiber slack (900 micron fiber only). Opening the FTB front covers provides access to the front side of the adapter packs and to the front radius limiters, which facilitate the routing of interconnect or cross-connect patch cords. The front covers also include designation labels to identify the optical circuits.

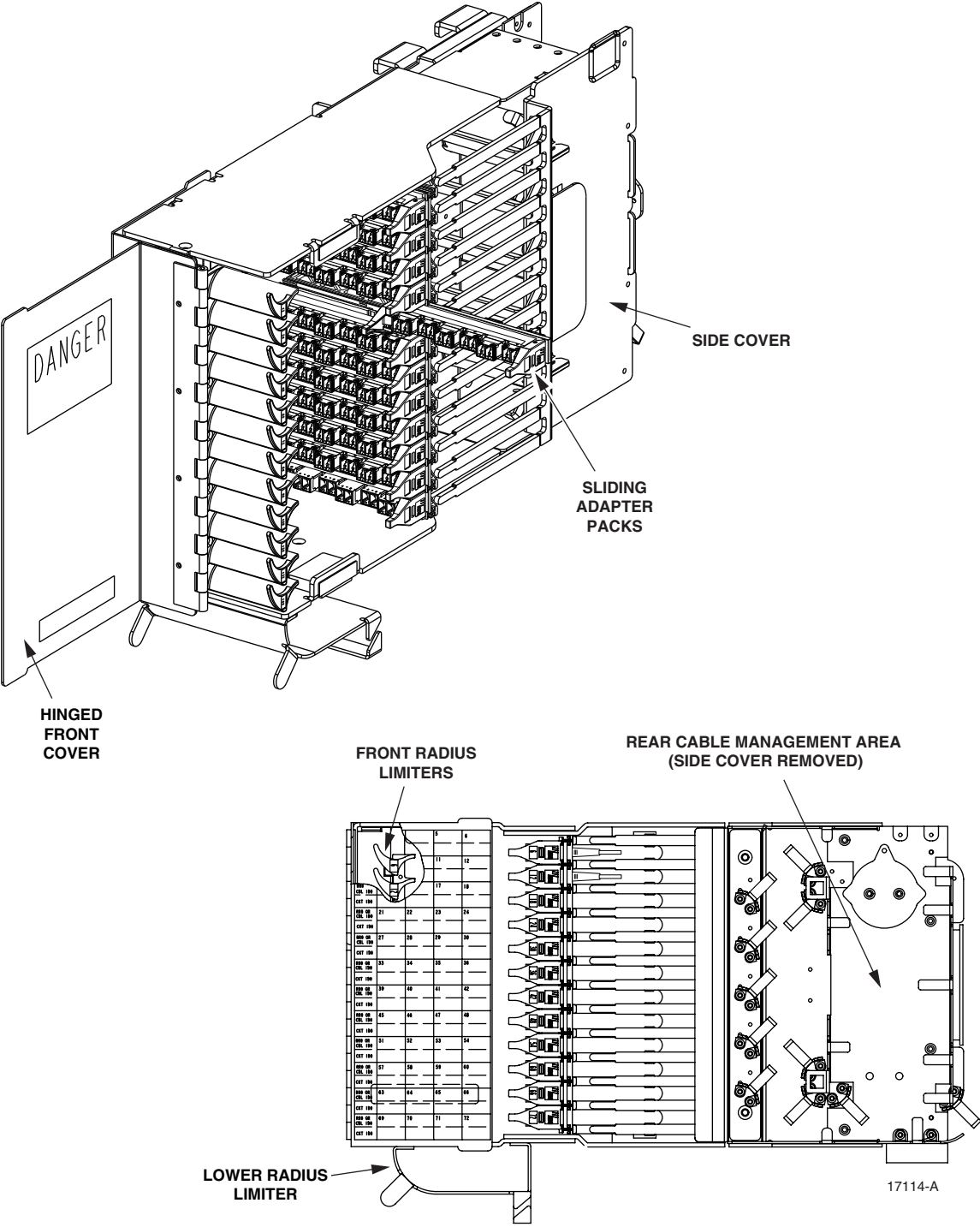

Figure 2. Fiber Termination Block

1.1.3 Options That Affect Installation

Several FTB ordering options will affect the installation process:

- The FTB may be ordered in either a pre-terminated or adapter only version. In the pre-terminated version, shown in [Figure 3](#), the FTB includes an installed OSP or IFC cable. One end of the cable is connected to the rear side of the adapters within the FTB. The other end of the OSP/IFC cable is coiled on a spool. At the job site, the free end of the OSP/IFC cable must be uncoiled from the spool and then routed to another location for splicing or connection to the OSP or FOT equipment circuits. In the adapter only version, the FTB does not include an OSP or IFC cable. Adapter only blocks are designed for terminating FOT equipment patch cords. To use an adapter only block with OSP or IFC cable, a conversion kit is required.

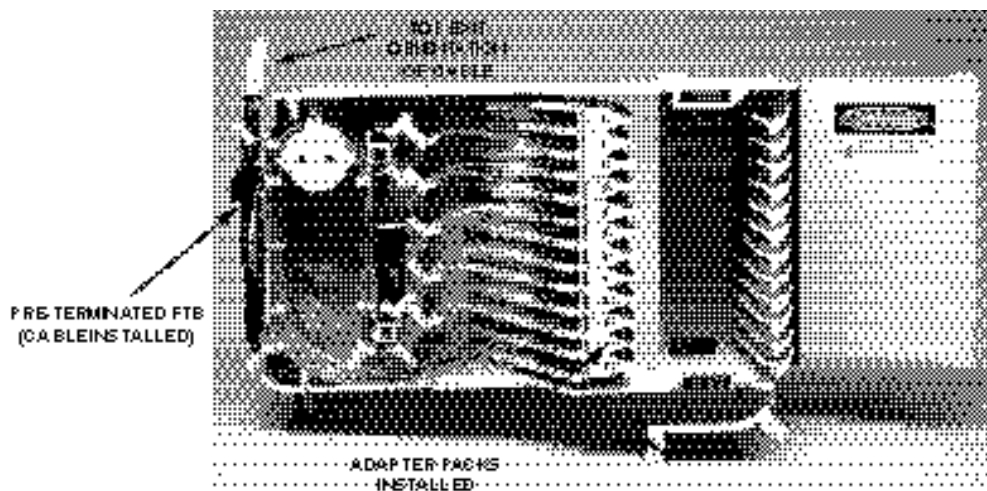

Figure 3. Pre-Terminated FTB

- The FTB may be ordered with a top or bottom exit orientation for the OSP/IFC cable or FOT equipment patch cords. With the top exit orientation, the OSP/IFC cable or FOT equipment patch cords must be routed out of the FTB toward the top. With the bottom exit orientation, the OSP/IFC cable or FOT equipment patch cords must be routed out of the FTB toward the bottom.
- The FTB may be ordered with a left or right orientation. With the left orientation, the FTB installs on the left side of the frame. With the right orientation, the FTB installs on the right side of the frame.

1.1.4 Accessories

The following accessories are available for use with the FTB:

- **Cable Clamp Kits**—Provide a clamp and other hardware required for securing IFC or OSP cables to the rear side of the FTB. Each FTB has three cable clamp positions.
- **IFC Cable Assemblies**—Are available with singlemode or multimode fiber in specified lengths and with specified connectors.
- **Patch Cords**—Are available with specified connectors in standard lengths of 6.0, 7.0, 8.0, 9.0, and 12.0 meters.
- **Adapter Packs**—Are available separately with specified adapters. Use as replacements for existing adapter packs or to add termination capacity. Each FTB provides 12 adapter pack mounting slots.
- **Mini-VAMs**—Provide the means to incorporate optical splitters or wave division multiplexers into the FTB. Each occupies one adapter pack mounting slot.
- **In-Line Attenuators**—Install between an adapter and connector. Can be mounted on the front side of an adapter pack.
- **Connector Cleaning Kit**—Provides all the materials required to correctly clean fiber optic connectors and adapters.

1.2 Applications

The FTB may be used to support either interconnect or cross-connect frame applications. The following sub-sections explain the basic principles of each type of frame application.

1.2.1 Interconnect Application

In an interconnect application, only the OSP circuits are terminated at the frame. The FOT equipment is connected directly to the OSP terminations using interconnect patch cords. The excess patch cord slack is stored on a storage panel at the front of the frame. [Figure 4](#) depicts a typical interconnect application. An interconnect application uses the entire frame for terminating OSP circuits. An overhead or underfloor guideway system such as the FiberGuide system must be used for routing the interconnect patch cords to the frame.

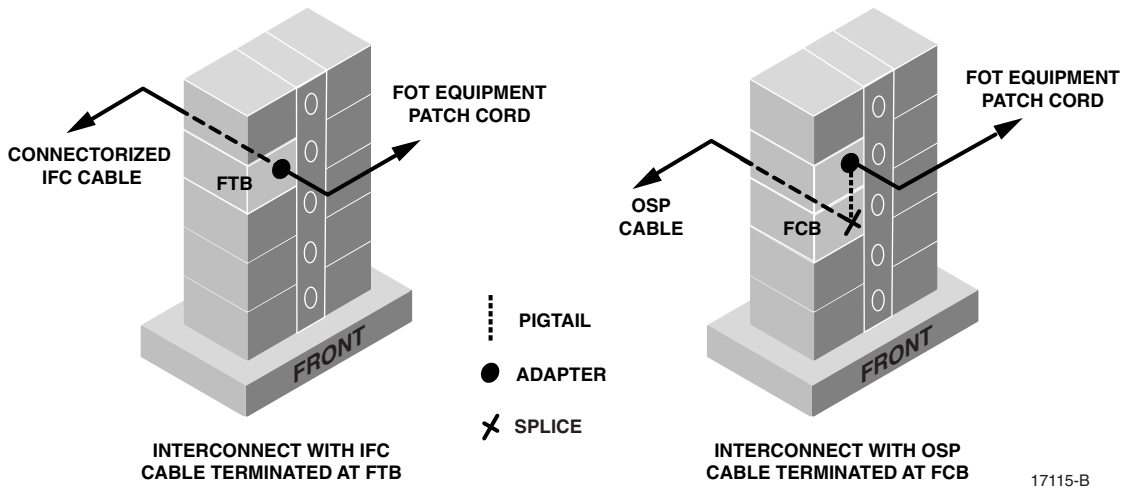

Figure 4. Typical Interconnect Application

1.2.2 Cross-Connect Application

In a cross-connect application, both FOT equipment circuits and OSP circuits are terminated at the frame. An FOT equipment circuit may be connected to an OSP circuit, an FOT equipment circuit may be connected to another FOT equipment circuit, or an OSP circuit may be connected to another OSP circuit using a cross-connect patch cord. The excess patch cord slack is stored on a storage panel at the front of the frame. Figure 5 depicts a typical cross-connect application using the FMDF.

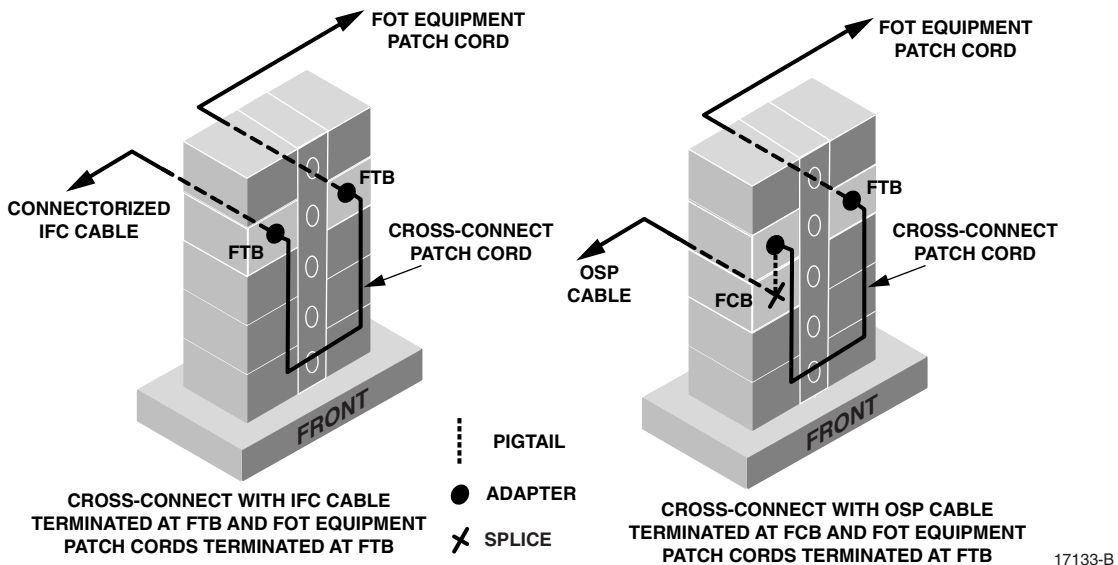

Figure 5. Typical Cross-Connect Application

1.3 Specifications

The specifications for the FTB are shown in Table 1.

Table 1-1. FTB Specifications

PARAMETER	SPECIFICATION	REMARKS
Physical		
Number of Terminations	48 or 72	
Connector types	SC, FC, ST, or E-2000	
Environment		
Temperature		
Operating	-40° C to 65° C (-40° F to 149° F)	
Storage	-55° C to 85° C (-85° F to 185° F)	
Relative Humidity		
Operating	Up to 80%	No condensation
Storage	Up to 95%	No condensation

2 UNPACKING, INSPECTION, AND ASSEMBLY

This section provides procedures for unpacking and inspecting the FTB and for assembling those versions of the FTB that require some assembly.

2.1 Unpacking and Inspecting the Product

Use the following procedure to unpack and inspect the FTB.

1. Inspect the exterior of the shipping container for evidence of rough handling that may have damaged the contents of the container.
2. Unpack the FTB and inspect for possible damage.
3. If damage is detected or if parts are missing, file a claim with the commercial carrier and then notify CommScope Customer Service. Save damaged carton for inspection by carrier.
4. Refer to [Section 6](#) for CommScope contact numbers if needed.
5. Even if no damage is evident, save the shipping container in case the equipment requires shipment at a future date.

2.2 Adapter Pack Installation

Adapter packs may be ordered separately and installed in the FTB as needed. Use the following procedure to install adapter packs in the FTB.

1. Open the FTB front covers and locate the adapter pack mounting slots.
 2. Orient the adapter pack for installation as shown in [Figure 6](#).
- ▶ **Note:** Split-type adapter packs must be oriented to match the designation labels on the FTB front covers.

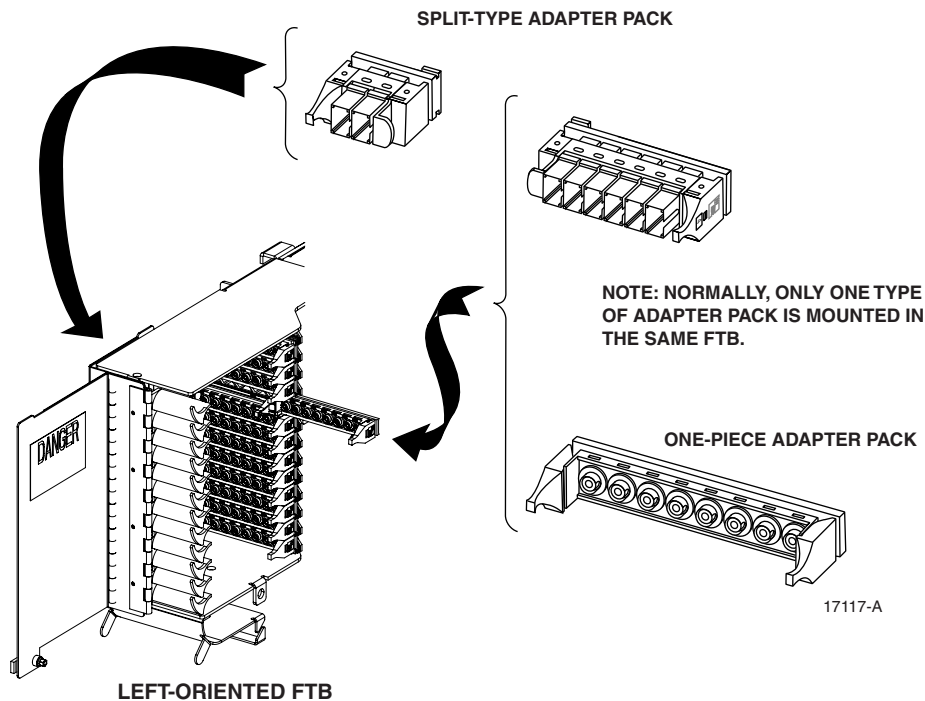

Figure 6. Adapter Pack Orientation and Installation in FTB

3. Insert the adapter pack into the designated mounting slot and slide it inward until it clicks into place.
- ▶ **Note:** If installing split-type adapter packs, install the left half of the pack in the mounting slot from the left side, and install the right half in the mounting slot from the right side. The end of the adapter pack without the rotating handle should be inserted into the mounting slot first.
4. Repeat the installation procedure for each adapter pack.
- ▶ **Note:** If it is necessary to remove an adapter pack, rotate the rotating handle outward to eject the adapter pack from the FTB. Slide the adapter pack out until it contacts the internal detent. For split-type adapter packs, pull out on the inside tab, as shown in [Figure 7](#), to release the internal detent. For one-piece adapter packs, pull out on the inside rotating handle to release the internal detent.

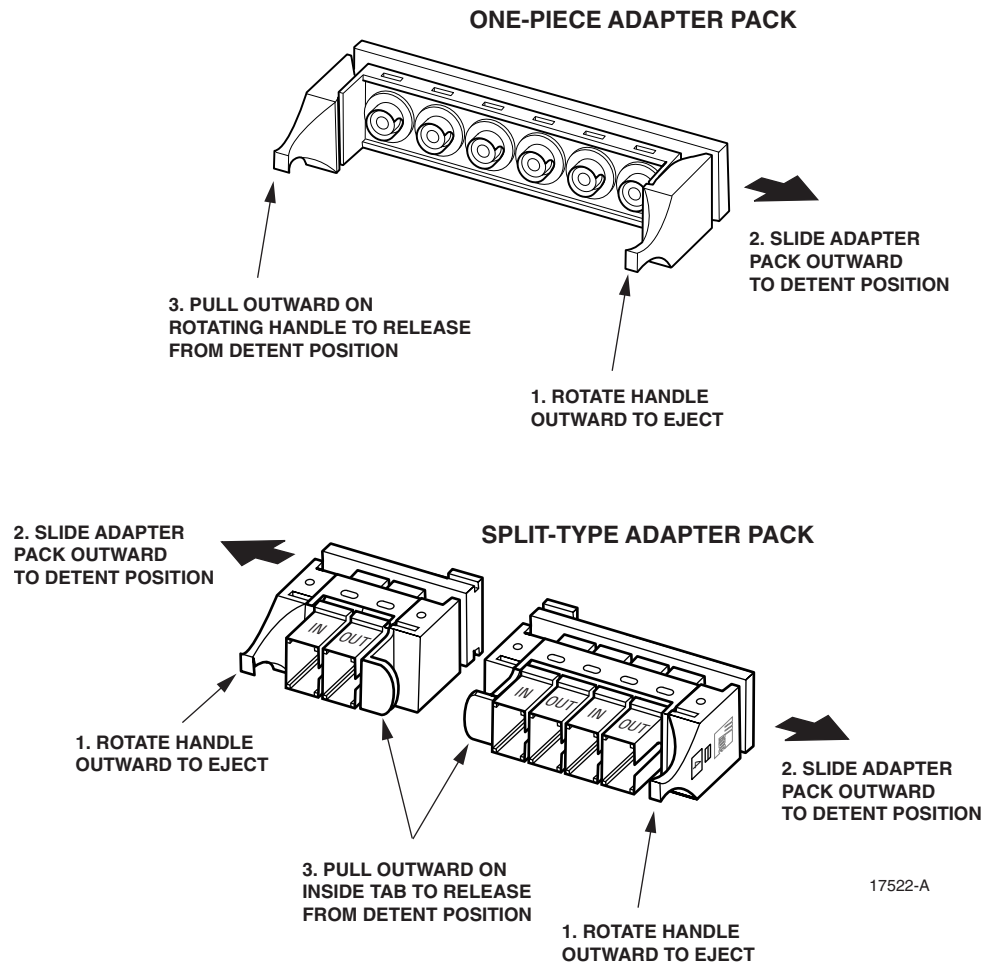

Figure 7. Adapter Pack Removal From FTB

3 IFC OR OSP CABLE INSTALLATION

This section describes how to install connectorized IFC or OSP cable in the FTB. If the FTB is pre-terminated by the factory or will only be used for terminating FOT equipment patch cords, skip this entire section and proceed to [Section 4](#).

► **Note:** CommScope recommends that FTBs should be purchased pre-terminated from the factory with the IFC or OSP cable stubs attached.

If necessary, the IFC or OSP cable may be installed after the FTB is mounted in the NGF rack. However, it is much easier to install the OSP or IFC cable before the FTB is mounted.

3.1 Preparing Cable for Installation

IFC or OSP cables purchased from CommScope for installation in the FTB are pre-dimensioned and do not require any special preparation prior to installation. If the IFC or OSP cables are not purchased from CommScope, prepare the cables for installation using the breakout dimensions shown in [Figure 8](#) and [Figure 9](#).

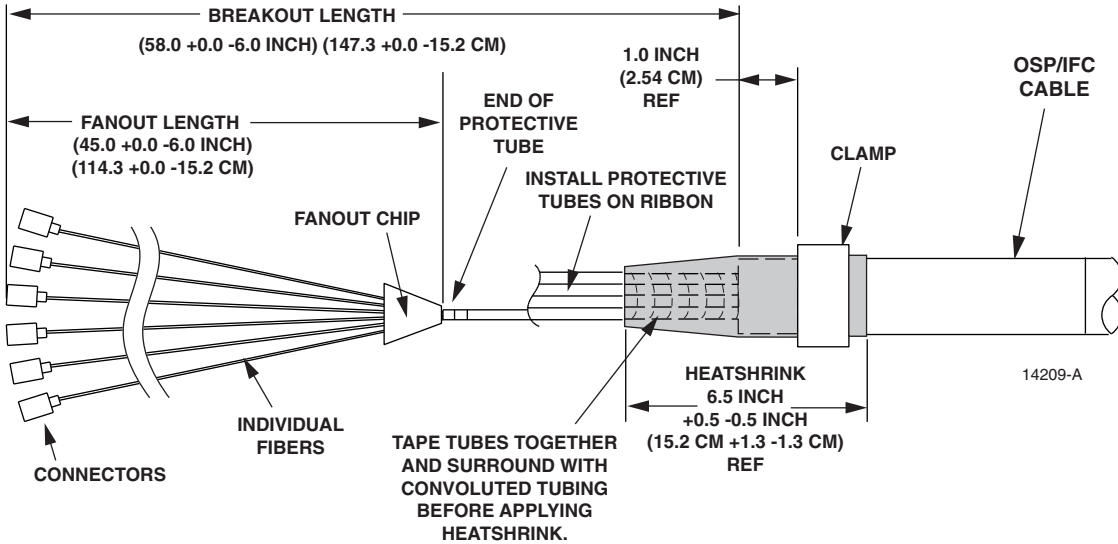

Figure 8. OSP Stranded Cable or OSP/IFC Ribbon Cable Breakout Dimensions

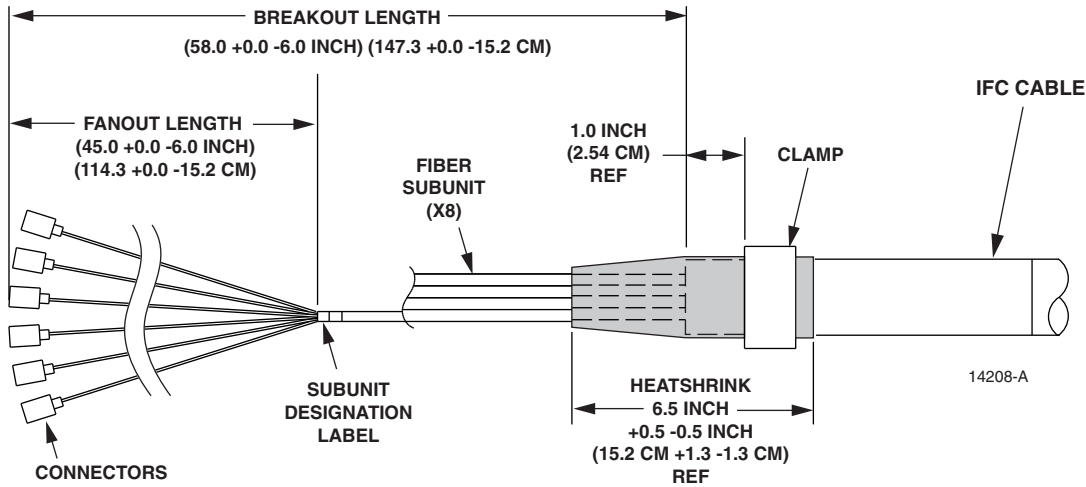

Figure 9. IFC Stranded Cable Breakout Dimensions

Before the IFC or OSP cable is clamped to the FTB, the cable may be routed and installed within the building or it may be coiled up near the frame for routing and installation after the FTB is installed in the frame. If the cable will be routed and installed before it is clamped to the FTB, leave sufficient slack at the frame end of the cable for installing the FTB in the NGF rack. If the cable will be routed and installed after it is clamped to the FTB, remove the cable from its spool and then coil it up in a figure 8 pattern as shown in [Figure 10](#), starting with the end that connects to the FTB. Make sure the end of the cable that does not connect to the FTB is coiled last.

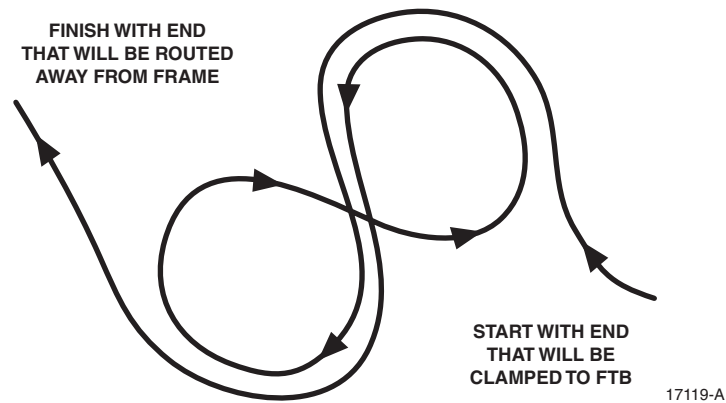

Figure 10. Storing Cable Using Figure 8 Pattern

3.2 Clamping Cable to FTB

Two clamp kits are available for securing the IFC or OSP cable to the FTB. Kit # NGF-ACCCLMP08 is used for cables with an outside diameter of 0.4 to 0.8 inches (1.01 to 2.03 mm). Kit # OSP-CLPSST-IFCL is used for cable with an outside diameter of 0.8 to 1.2 inches (2.03 to 3.05). Use the following procedure for installing either cable clamp kit.

1. Locate the cable clamp mounting position at the rear side of the FTB as shown in [Figure 11](#). Note that four clamping positions are provided. If more than one cable will be attached to the FTB, use the clamping positions in the order shown.

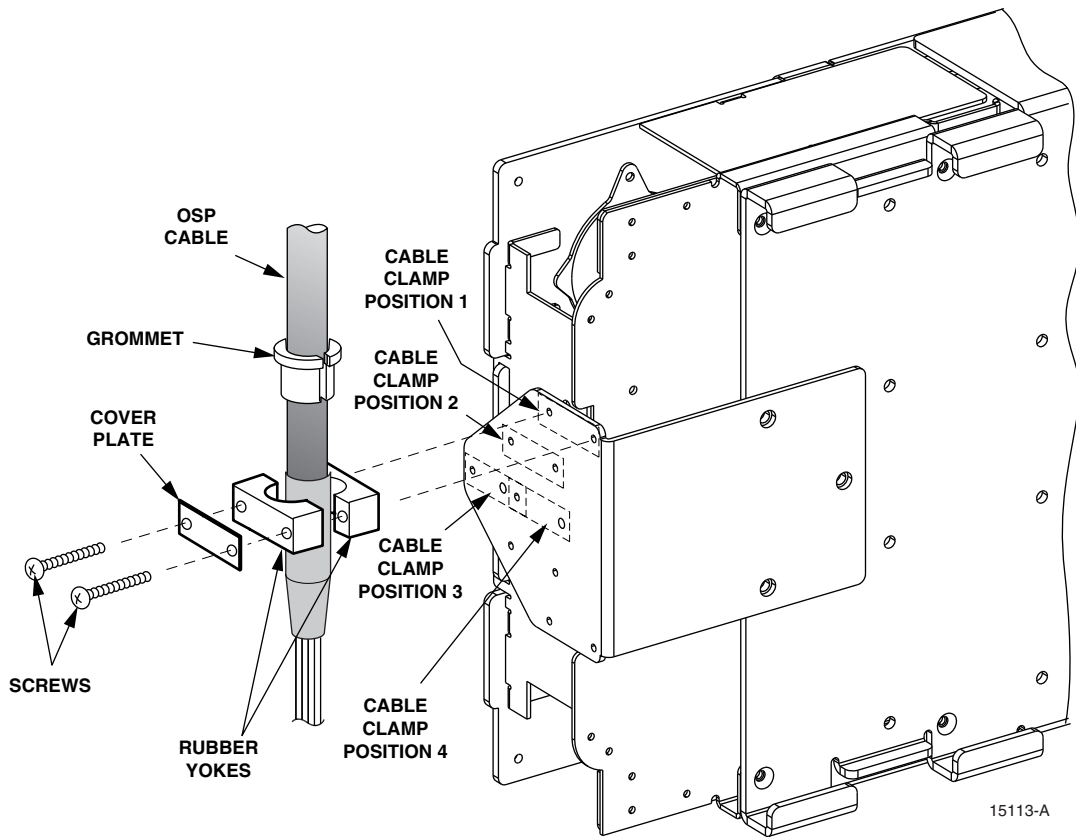

Figure 11. IFC/OSP Cable Clamp Installation

2. Remove the side cover from the FTB.
3. Verify that the FTB has the correct cable exit orientation (top or bottom) for the cable installation, as shown in [Figure 12](#).

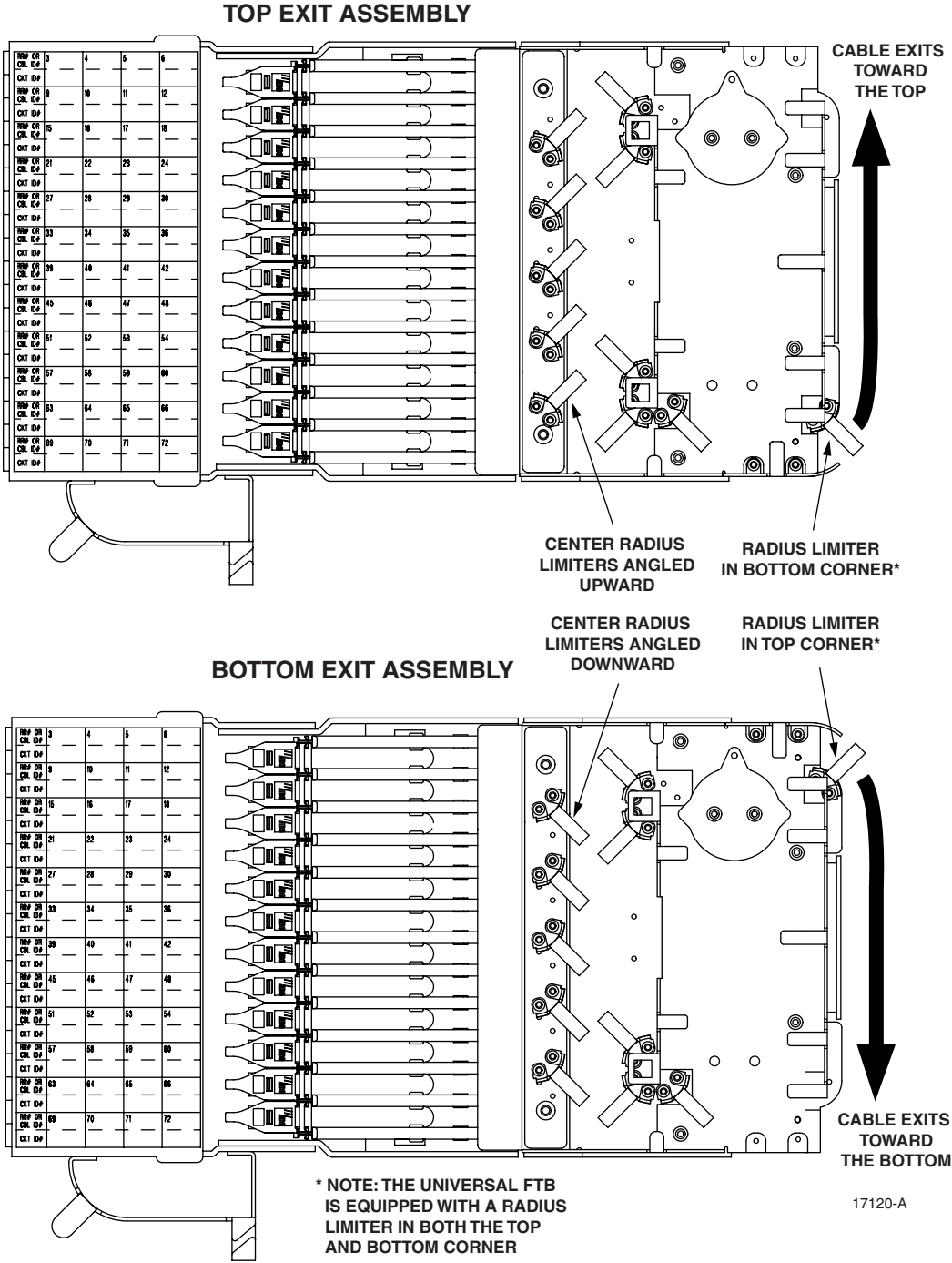

Figure 12. Cable Exit Orientation

4. Two rubber yokes and either three or four grommets (depending on the kit) are provided with the cable clamp kit for securing the cable to the FTB. Select the grommet that, when placed on the cable, results in the gap width shown in [Figure 13](#).

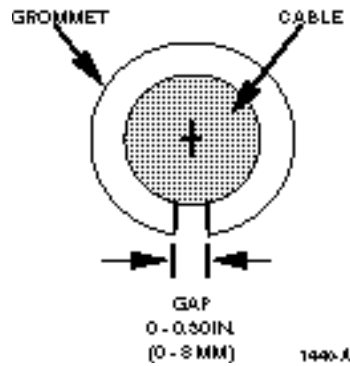

Figure 13. Grommet Selection

5. Place the rubber clamp yokes and the grommet selected in step 4 around the cable and then secure the cable to the FTB (see [Figure 11](#)).
- ▶ **Note:** If each of the grommets measured in step 5 have a gap that exceeds 0.30 inches (7.6 mm), a grommet is not required.
6. Repeat this procedure for each cable being installed.

3.3 Routing and Connecting Cable Fibers Within FTB

After the IFC or OSP cable is clamped to the FTB, use the following procedure to route and connect the cable fibers within the FTB and to store any excess slack. Refer to [Figure 14](#) if the cable exits the FTB toward the top or [Figure 15](#) if the cable exits the FTB toward the bottom:

1. Route the OSP/IFC cable fiber ribbon (if ribbon cable) or fiber sub-unit (if stranded cable) for the first group of circuits (start with circuit #1) to the break-out point within the FTB.
2. Place first fan-out chip or fiber sub-unit at the break-out point as shown in [Figure 16](#).
3. Route the fibers from the fan-out chip or fiber sub-unit once around the storage spool forming a slack loop.
4. From the top of the storage spool, route the fibers to the rear side of the adapter pack for the first group of circuits (starting with #1)
5. Eject the adapter pack by rotating the adapter pack handle outward.

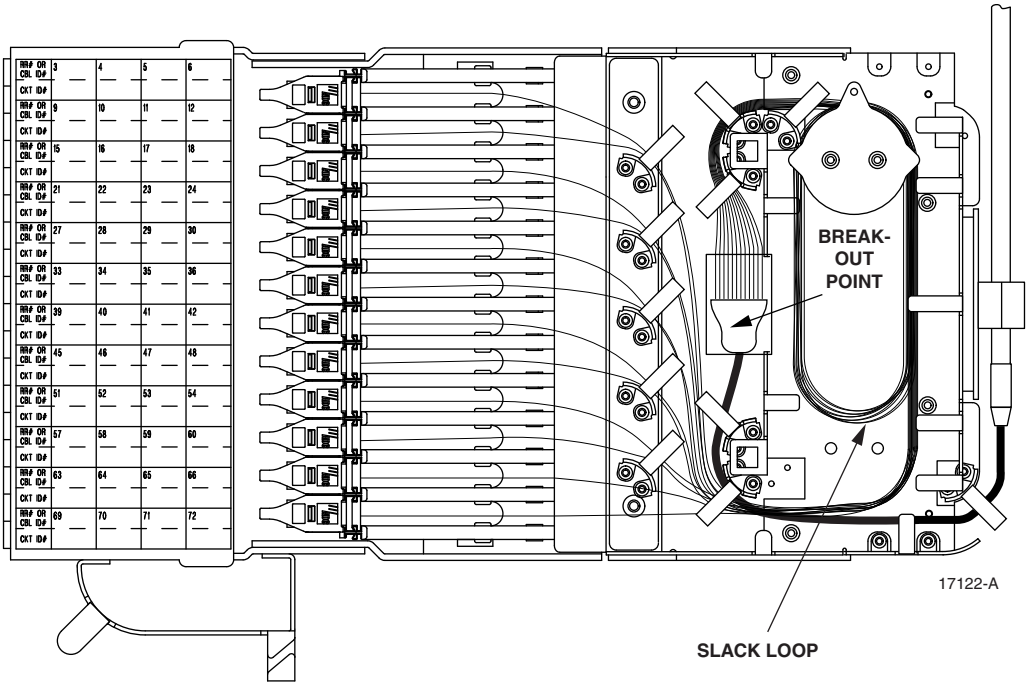

Figure 14. Top Exit Cable Routing

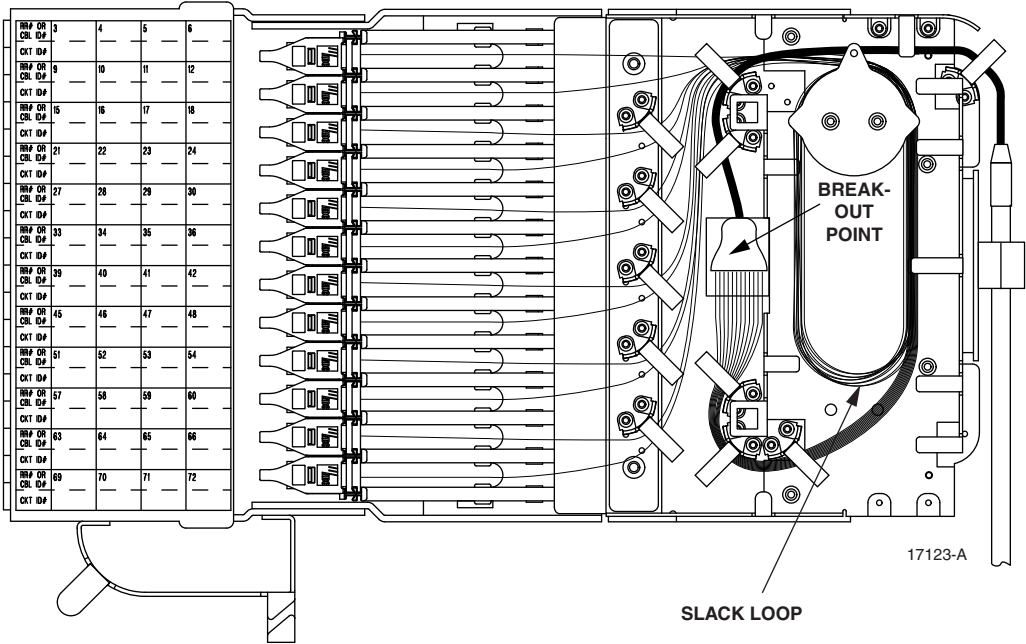

Figure 15. Bottom Exit Cable Routing

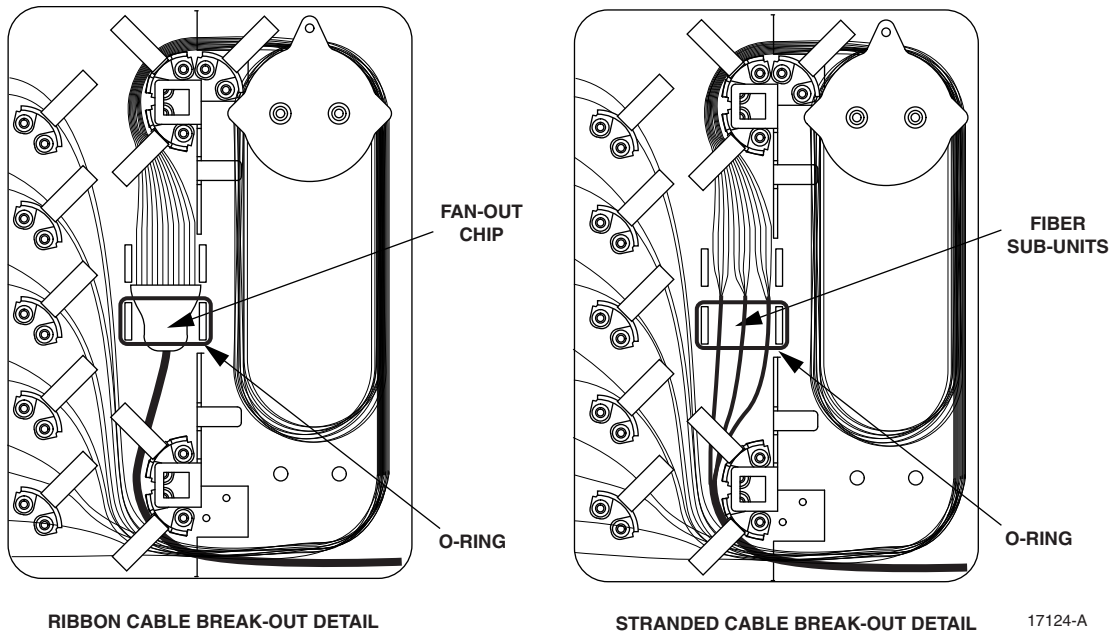

Figure 16. Break-Out Point Detail

- Slide the adapter pack out to provide access to the rear side of the adapters as shown in Figure 17.

► **Note:** If the FTB is equipped with split adapter packs, slide both sections of the adapter pack out to provide access to the rear side of the adapters.

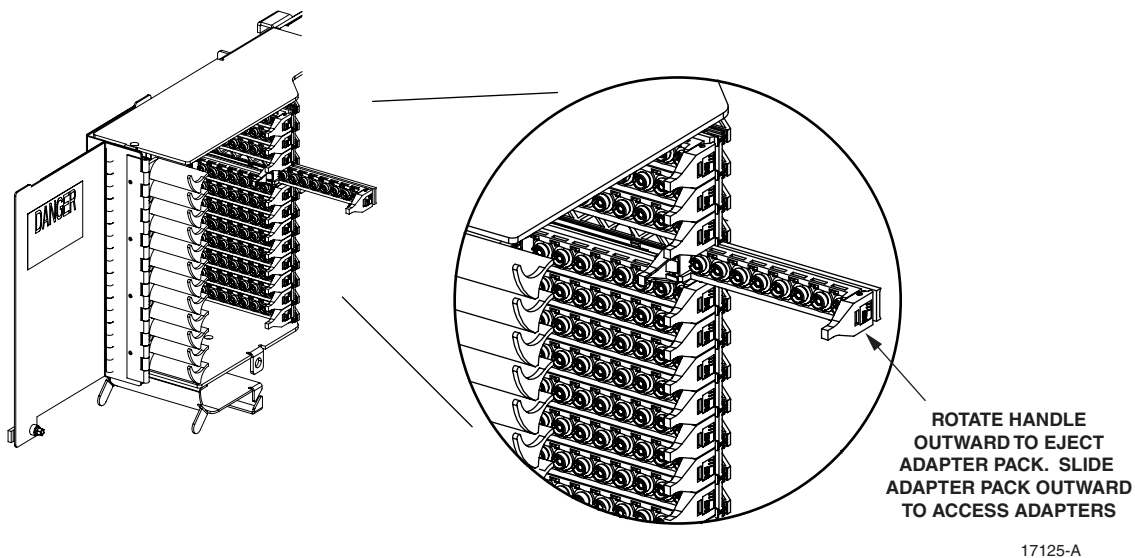

Figure 17. Access Adapter Packs in FTB

7. Remove the cover from each adapter and then connect each fiber connector to the appropriate adapter.
8. Slide the adapter pack back (both sections if a split adapter pack) to the center position.
9. Adjust the fiber storage loop to take up all excess fiber slack.
- ▶ **Note:** The fiber slack should hang loosely below the spool and should not be wound tightly around the spool.
10. Use the basic process outlined in steps 1–9 to route and connect the fibers from each fiber ribbon or fiber sub-unit.
11. Install the O-ring at the fiber break-out point to secure the fan-out chips or fiber sub-units to the FTB.

4 FTB INSTALLATION

This section describes how to mount the FTB on the NGF rack and how to route and secure the IFC or OSP cable. If the FTB will only be used for terminating FOT equipment patch cords and does not have an OSP/IFC cable attached, complete sub-section 4.1 then proceed to [Section 5](#).

4.1 Mounting FTB On Rack

Use the following procedure to mount the FTB on the NGF rack:

1. If the FTB does not have an IFC/OSP cable attached, or if an IFC/OSP cable was attached to the FTB in sub-section 3.2, proceed to step 7. If the FTB is pre-terminated by the factory and mounted on a spool assembly, proceed to step 2.
2. Place the cable spool with the enclosed pre-terminated FTB next to the NGF rack and then position the spool so it is supported by the two plywood side supports.
- ▶ **Note:** The FTB is mounted inside the cable spool and is designed to rotate as the cable is unwound from the spool.
3. Unwind the free end of the cable from the spool and then route and install the cable within the building as required by the application. Leave sufficient slack at the frame end of the cable for mounting the FTB in the NGF rack.
4. When all of the cable is unwound from the spool, place the cable spool on its side with the smaller of the two plywood side supports facing up as shown in [Figure 18](#).
5. Remove the four wing nuts from the side of the spool and then lift the spool side support assembly off the spool.
6. Remove the two foam packing blocks from the top of the FTB and then carefully lift the FTB out from the center of the spool.

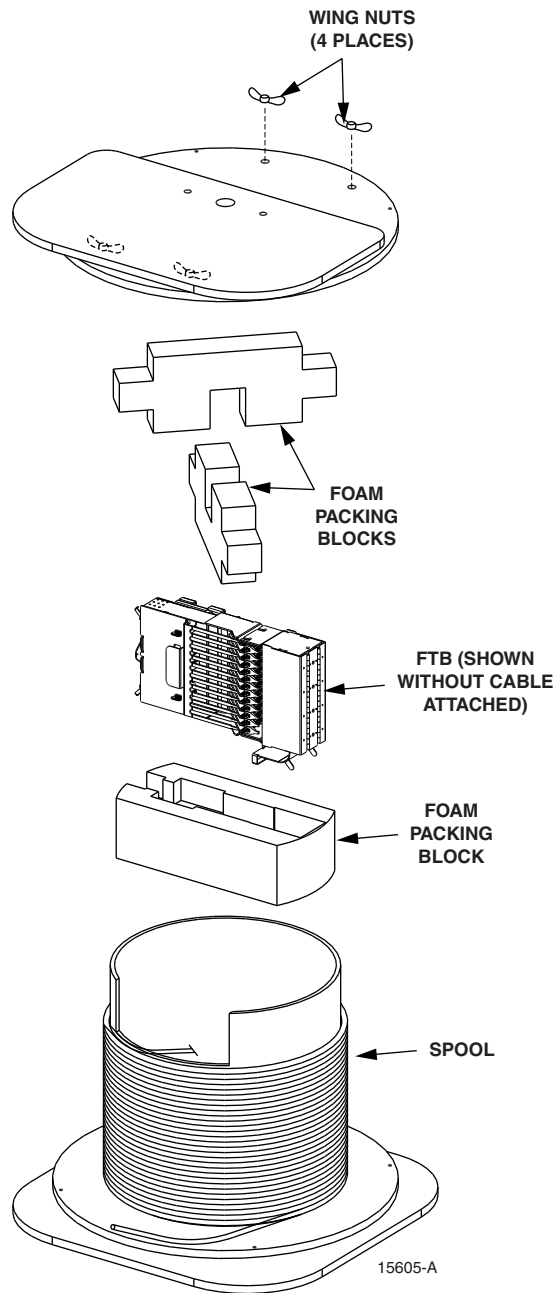

Figure 18. Pre-Terminated FTB Spool Assembly

7. Locate the designated mounting position for the FTB. In a new rack installation, the rack may be populated by starting at the bottom and working toward the top or by starting at the top and working toward the bottom. Left-oriented FTBs mount only on the left side of the rack and right-oriented FTBs mount only on the right side of the rack.
8. Slide the FTB onto the appropriate mounting bracket at the front of the rack as shown in [Figure 19](#).

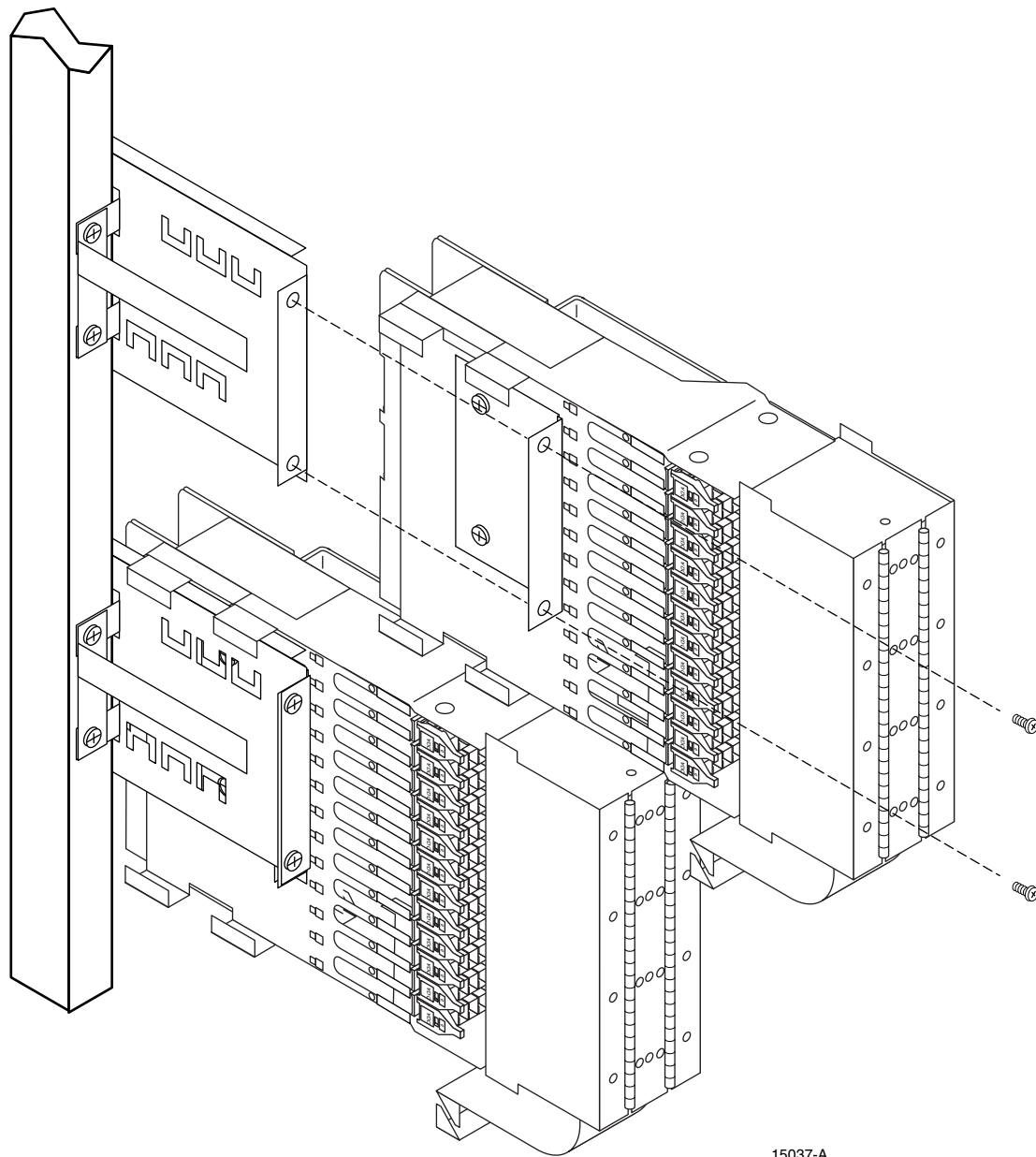

Figure 19. FTB Installation on Rack

9. Secure the FTB to the rack mounting bracket using the two #12-24 screws provided.
10. If an IFC/OSP cable is attached to the FTB, place the cable between the FTB mounting brackets and the vertical cable brackets.
11. Repeat steps 1–10 for each FTB.

4.2 Securing IFC or OSP Cable to Rack

The method used for securing cables to the frame is determined by the whether the cables enter the frame from the top or the bottom. Refer to [Figure 20](#) for the recommended method for placing and securing cables to the rack based on how the cables enter the frame.

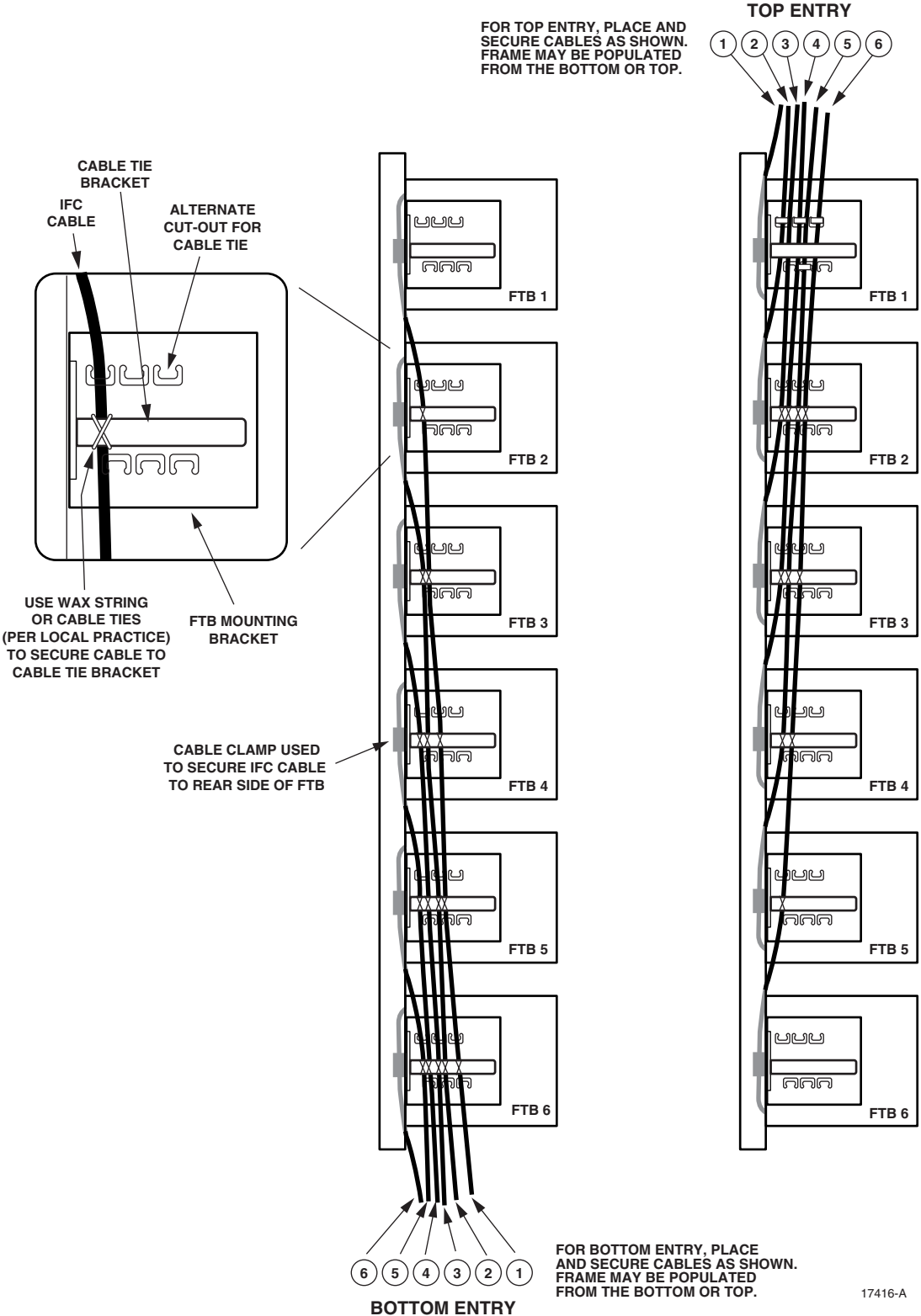

Figure 20. Securing IFC or OSP Cables to the NGF Rack

5 FOT EQUIPMENT PATCH CORD INSTALLATION

This section provides procedures for terminating FOT equipment patch cords at the FTB, routing the patch cords to the FOT equipment through either an overhead or underfloor guideway system, and securing the patch cords to the NGF rack.

When required by the application, patch cords, instead of an IFC or OSP cable, may be used to terminate FOT equipment circuits at the FTB. The FTB should be installed on the NGF rack (see [Section 4](#)) before starting this series of procedures.

5.1 Terminating Patch Cord at FTB

Begin FOT equipment patch cord installation by terminating the patch cord at the FTB as described in the following procedure. Then refer to sub-section 5.2, 5.3, 5.4, or 5.5 (whichever applies) for routing the patch cord between the NGF frame and the FOT equipment.

Use the following procedure to terminate FOT equipment patch cords at the FTB.

1. Locate the FTB within the NGF rack and remove the FTB side cover to provide access to the inside of the FTB chassis.
2. If using an overhead guideway, route the patch cord into the FTB from the top as shown in [Figure 21](#). If using an underfloor guideway, route the patch cord into the FTB from the bottom as shown in [Figure 22](#).

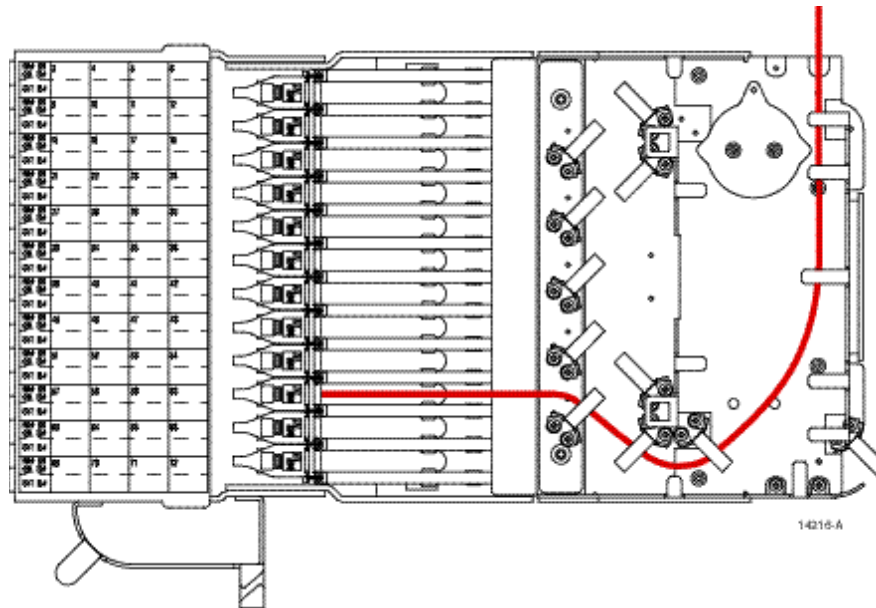

Figure 21. FOT Equipment Patch Cord Internal FTB Routing Detail - Top Entry

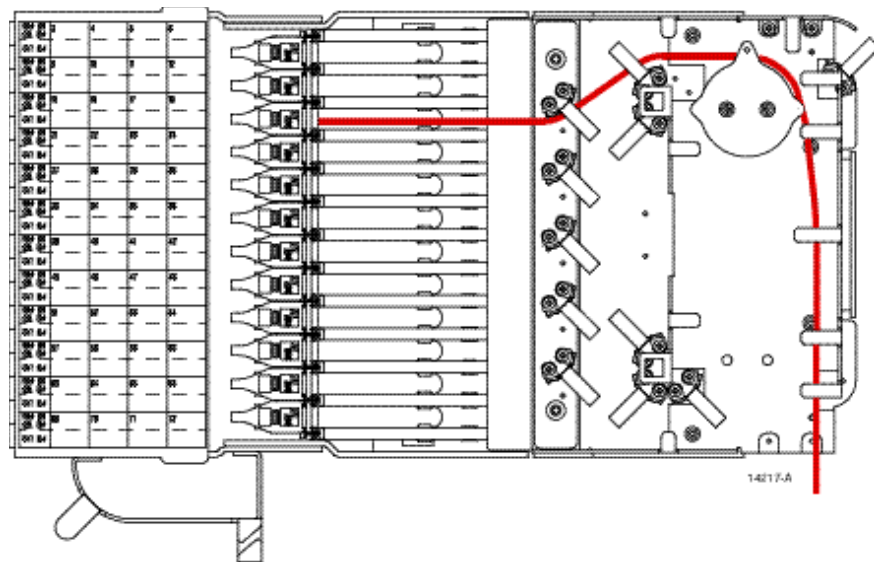

Figure 22. FOT Equipment Patch Cord Internal FTB Routing Detail - Bottom Entry

3. Locate the adapter pack that houses the adapter for the required termination.
 4. Eject the adapter pack by rotating the adapter pack handle outward.
 5. Slide the adapter pack out to provide access to the rear side of the adapters as shown in [Figure 23](#).
- **Note:** If the FTB is equipped with split adapter packs, slide the appropriate section of the adapter pack out to provide access to the rear side of the adapter.
6. Remove the cover from the adapter and connect the patch cord connector to the appropriate adapter.
 7. Slide the adapter pack back to the center position.
 8. Use the basic process outlined in steps 1–7 for routing and terminating each FOT equipment patch cord at the FTB.

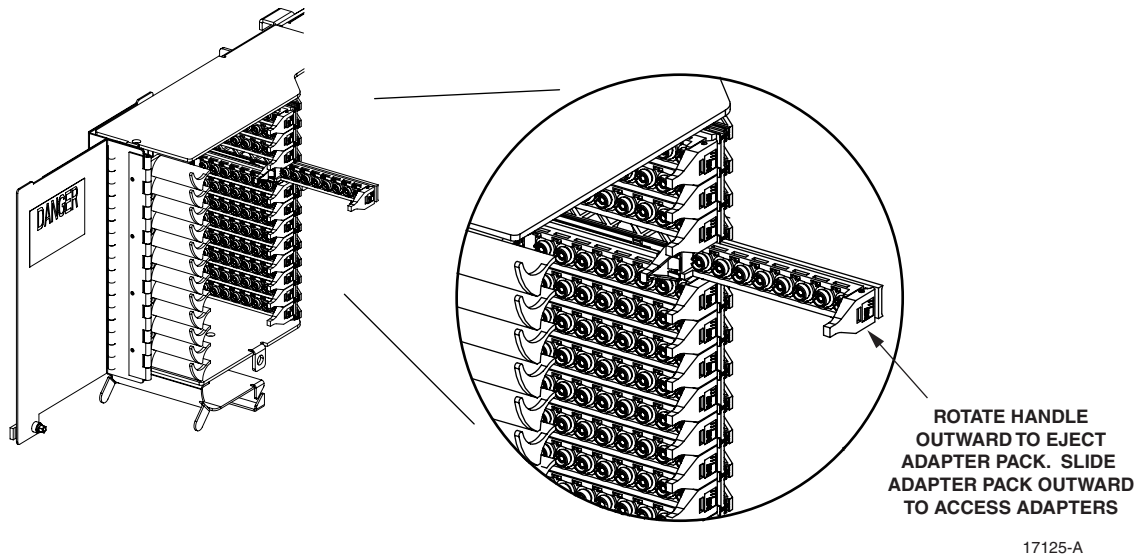

Figure 23. Access Adapter Packs in FTB

5.2 Installing FOT Equipment Patch Cords—Overhead Without FOTSB

Use the following procedure to install FOT equipment patch cords when an overhead fiber raceway system will be used for routing and when a Fiber Optic Terminal Storage Bay (FOTSB) is not provided at the frame.

Refer to [Figure 24](#) for a diagram of the routing procedure.

1. Terminate the FOT equipment patch cords at the FTB as described in topic 6.1.
- ▶ **Note:** Start with either the highest or lowest FTB and then continue working in order from top-to-bottom or from bottom-to-top as each FTB is terminated.
2. Route the patch cord through the vertical channel at the side of the rack and into the overhead raceway system at the top of the frame.
3. Route the patch cord through the overhead raceway system to the FOT equipment.
4. Connect the patch cord to the FOT equipment.
5. Accumulate and store the excess patch cord length at the FOT equipment.
6. Repeat steps 1–5 as each FTB is terminated.

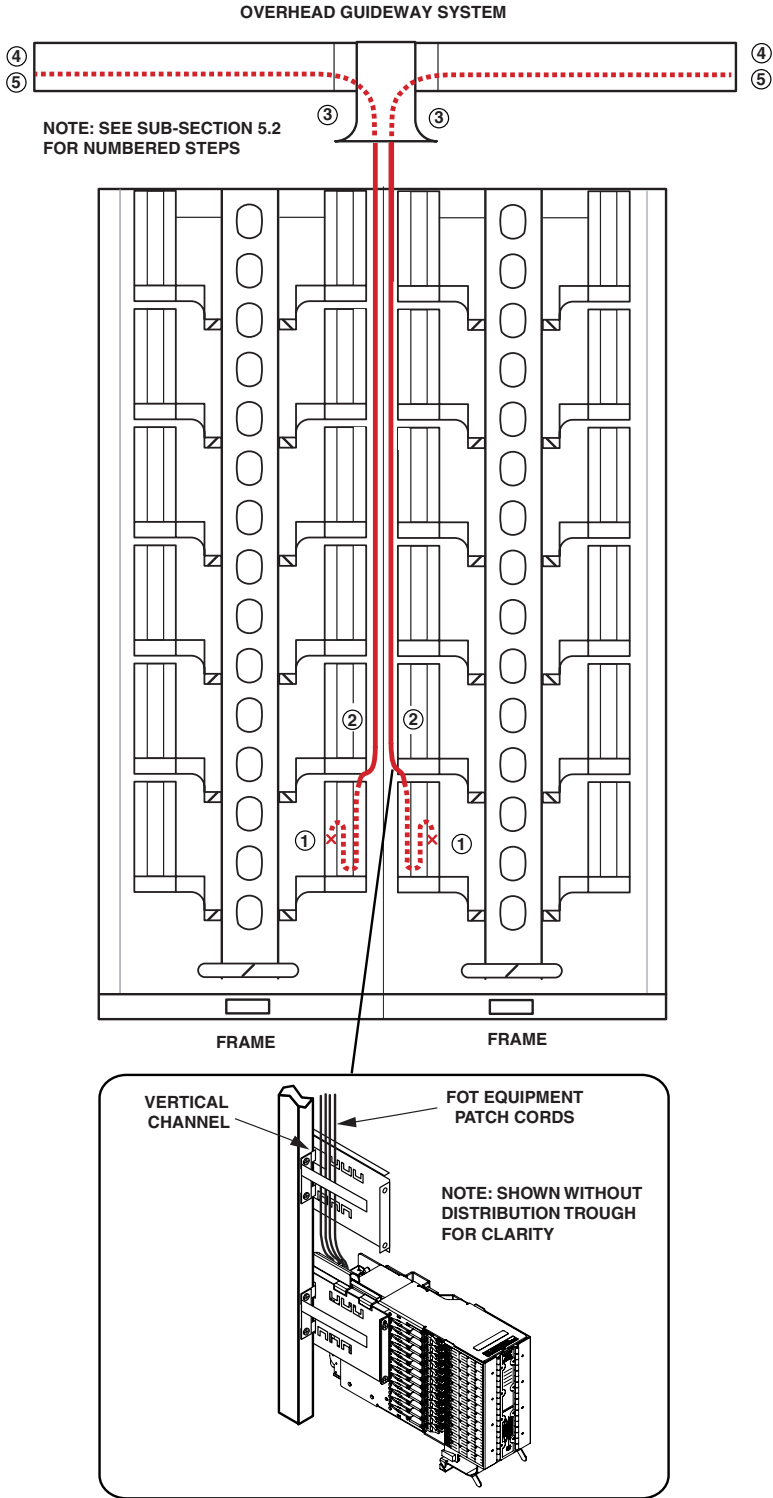

Figure 24. Overhead FOT Equipment Patch Cord Installation (Without FOTSB)

5.3 Installing FOT Equipment Patch Cords—Overhead With FOTSB

Use the following procedure to install FOT equipment patch cords when an overhead fiber raceway system will be used for routing and when a Fiber Optic Terminal Storage Bay (FOTSB) is provided at the frame.

Refer to [Figure 25](#) for a diagram of the routing procedure.

► **Note:** When using a FOTSB, always use up-configured FTBs.

1. Connect the patch cord to the FOT equipment.
2. Route the patch cord through the overhead raceway system to the top of the FOTSB.
3. Route the patch cord through the vertical cable guides to the bottom of the FOTSB.
4. Allow the patch cord slack to temporarily rest at the bottom of the FOTSB.
5. Terminate the patch cord at the FTB as described in topic 6.1.
6. Route the patch cord over the adjacent bend radius limiter and through the FOTSB vertical cable guides to the bottom of the FOTSB.
7. Form a storage loop out of the excess patch cord length at the bottom of the FOTSB. Make sure the lower ends of the loop pass under the edge protector spools at the bottom of the FOTSB storage spool panel.
8. Store the excess patch cord slack by hanging the storage loop over the appropriate storage spool.

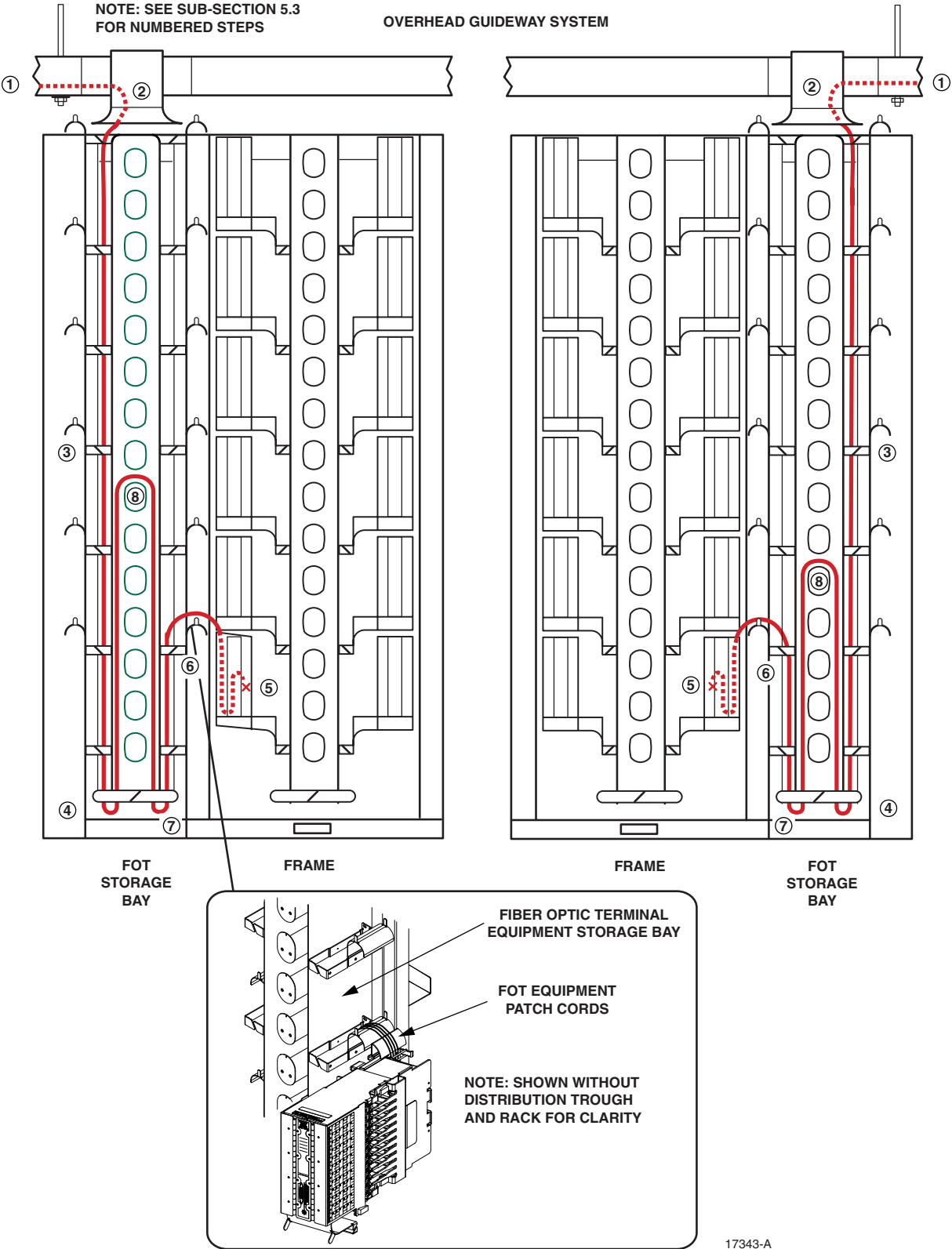

Figure 25. Overhead FOT Equipment Patch Cord Installation (With FOTSB)

5.4 Installing FOT Equipment Patch Cords—Underfloor Without FOTSB

Use the following procedure to install FOT equipment patch cords when an underfloor fiber raceway system will be used for routing and a when a Fiber Optic Terminal Storage Bay (FOTSB) is not provided at the frame:

Refer to [Figure 26](#) for a diagram of the routing procedure.

1. Terminate the FOT equipment patch cord at either the top FTB or bottom FTB as described in topic 6.1.
- ▶ **Note:** Start with either the highest or lowest FTB and then continue working in order from top-to-bottom or from bottom-to-top as each FTB is terminated.
2. Route the patch cord through the vertical channel at the side of the rack and into the underfloor raceway system at the bottom of the frame.
3. Route the patch cord through the underfloor raceway system to the FOT equipment.
4. Connect the patch cord to the FOT equipment.
5. Accumulate and store the excess patch cord length at the FOT equipment.
6. Repeat steps 1–5 as each FTB is terminated.

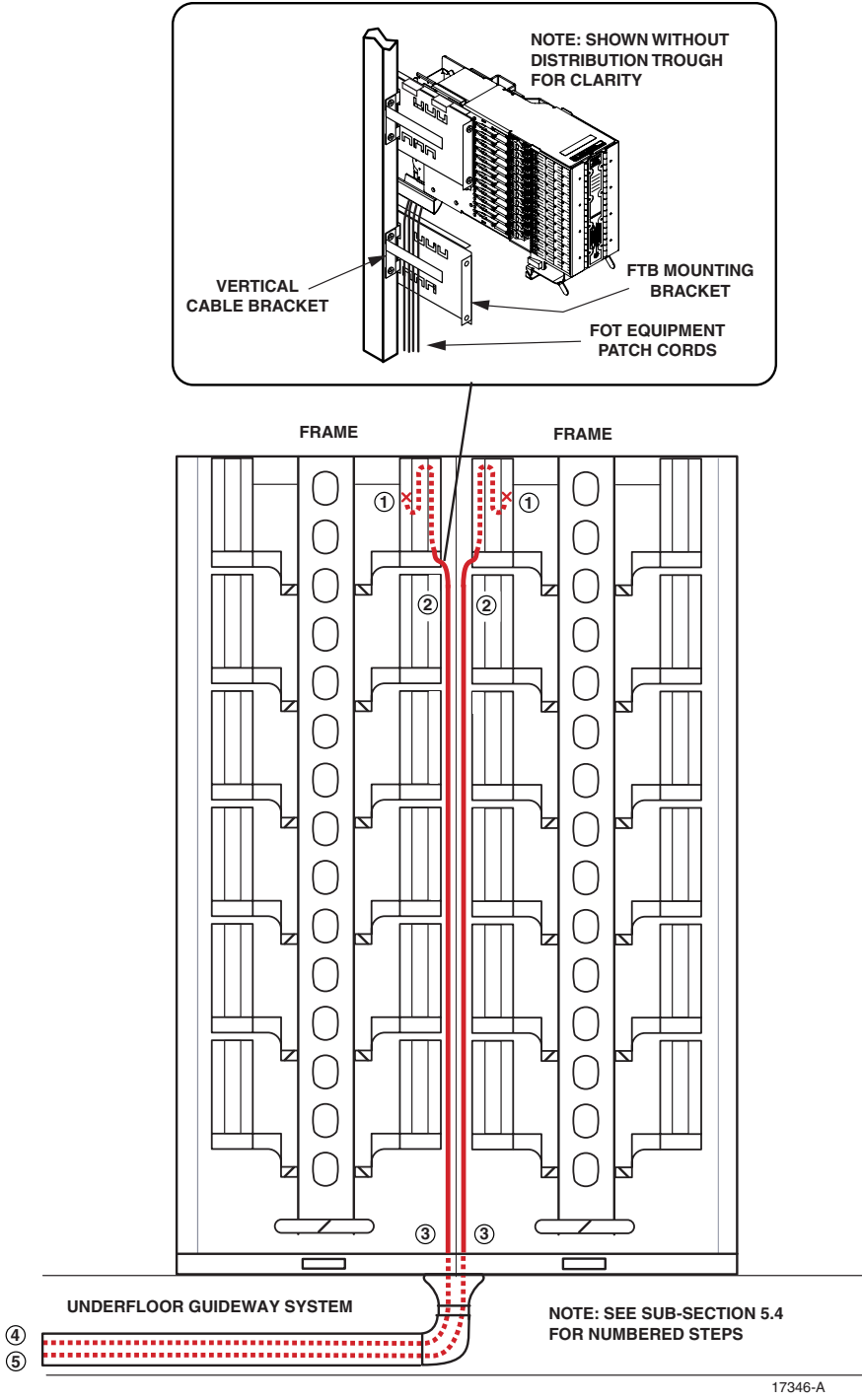

Figure 26. Underfloor FOT Equipment Patch Cord Installation (Without FOTSB)

5.5 Installing FOT Equipment Patch Cords—Underfloor With FOTSB

Use the following procedure to install FOT equipment patch cords when an underfloor fiber raceway system will be used for routing and when a Fiber Optic Terminal Storage Bay (FOTSB) is provided at the frame.

Refer to [Figure 27](#) for a diagram of the routing procedure.

► **Note:** When using a FOTSB, always use up-configured FTBs.

1. Connect the patch cord to the FOT equipment.
2. Route the patch cord through the underfloor raceway system to the bottom of the FOTSB.
3. Allow the patch cord slack to temporarily rest at the bottom of the FOTSB.
4. Terminate the patch cord at the FTB as described in topic 6.1.
5. Route the patch cord over the adjacent bend radius limiter and through the FOTSB vertical cable guides to the bottom of the FOTSB.
6. Form a storage loop out of the excess patch cord length at the bottom of the FOTSB. Make sure the lower ends of the loop pass under the edge protector spools at the bottom of the FOTSB storage spool panel.
7. Store the excess patch cord slack by hanging the storage loop over the appropriate storage spool.

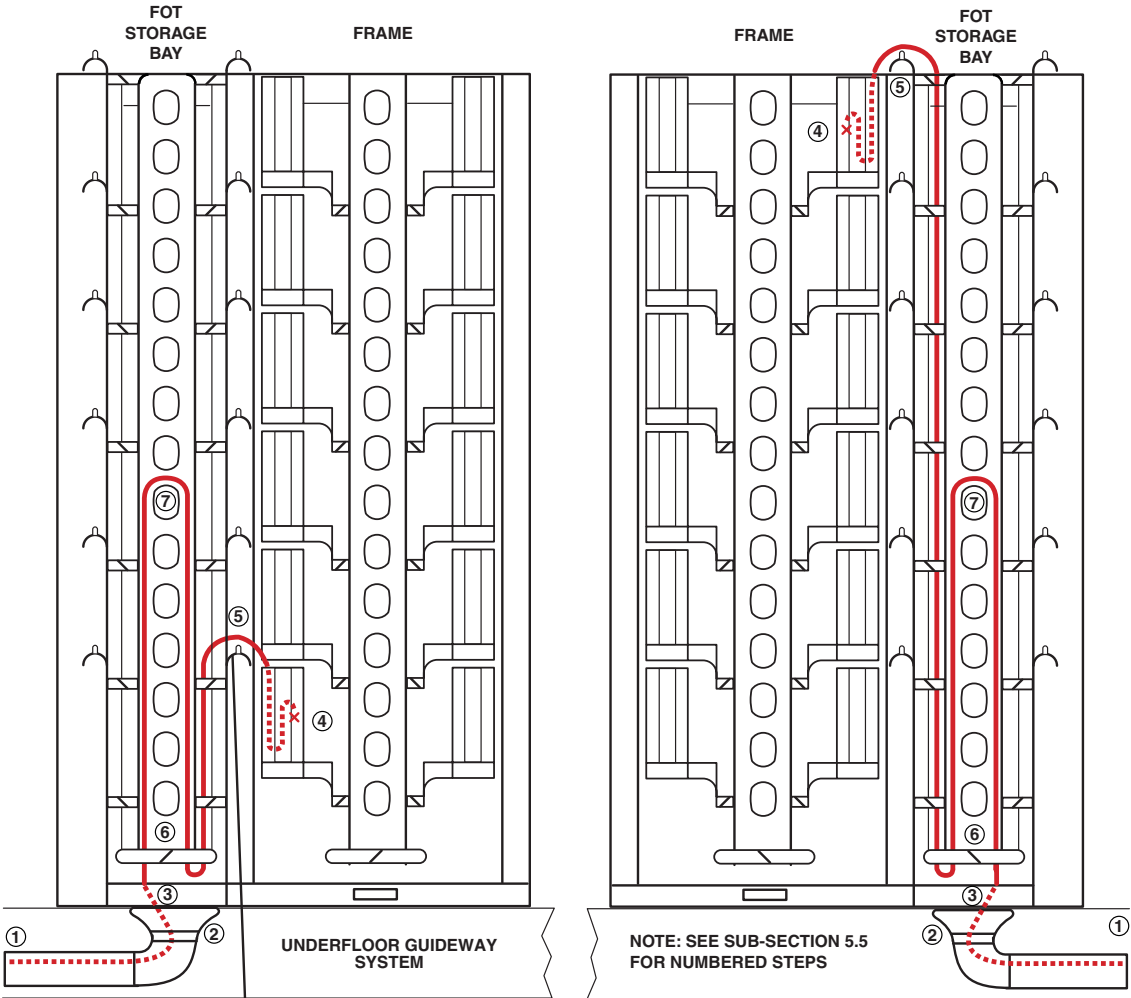

17344-A

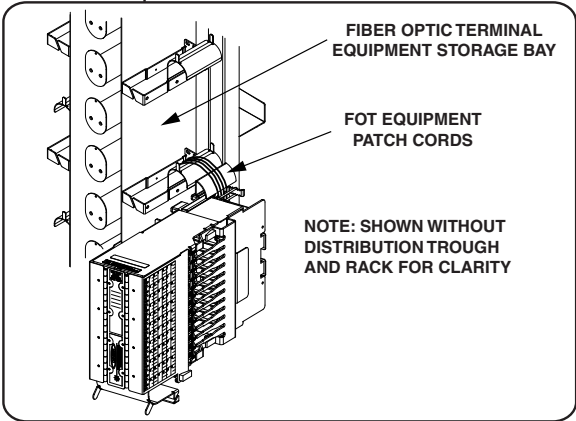

Figure 27. Underfloor FOT Equipment Patch Cord Installation (With FOTSB)

6 CUSTOMER INFORMATION AND ASSISTANCE

Visit our website or contact your local CommScope representative for more information.

- To find out more about CommScope® products, visit us on the web at www.commscope.com
- For technical assistance, customer service, or to report any missing/damaged parts, visit us at <http://www.commscope.com/SupportCenter>