

Installation Guidelines - – HELIAX® FiberFeed® Solutions

Fiber/Copper Cables: HTC1006 | HTC606 | HFA412 | DFJ

Related Support and Learning Opportunities Offered by the CommScope Infrastructure Academy

The insights and expertise contained in this manual represent just one small part of Andrew Solutions' global learning initiative. Few industries are evolving as quickly as wireless communications. Every technological innovation impacts what happens in the field. Our customers look to the CommScope Infrastructure Academy to make sure their technicians and installers are well trained, well-prepared, and well-educated to take advantage of opportunities as they evolve.

Field Engineering Services (FES)

Support services, such as our Field Engineering Services (FES) Group gives Andrew Solutions' customers access to technical support where and when it is needed the most — in the field. The FES team is staffed by an expert team of technicians who, in turn, are supported by some of the brightest and most experienced product line managers. With all of this knowledge and support the FES offers our customers access to hands-on, specialized training classes.

| | |
|---|-----------|
| Section 1: General Specifications | 02 |
| Section 2: Cable Construction / HELIAX® FiberFeed® Jumpers | 04 |
| Section 3: HELIAX® FiberFeed® Trunk Cables | 06 |
| Section 4: Breakout Procedure / LC Connection Considerations | 07 |
| Section 5: All-in-One Cleaner / Inspecting | 08 |
| Section 6: OVP Gland Identification / OVP Wiring | 09 |
| Section 7: Excess Cable Management | 13 |
| Section 8: Maintenance Check list / Fiber Troubleshooting | 14 |

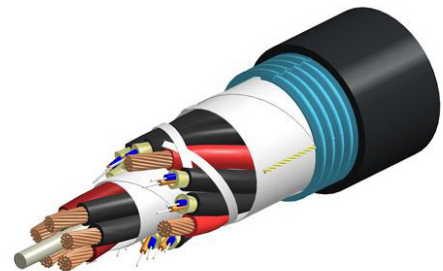

For more information, Contact Customer Service Center

United States and Mexico 1-800-255-1479 or 1-888-235-5732
International: +1-779-435-8579

For the most current, up-to-date information on all our products and product information please visit our eCatalog section at www.commscope.com/andrew.



General Specifications

| | | | |
|--------------------------|-----------------------------|-----------------------------|-----------------------------|
| Cable Type | HFT606-24S37-XXX | HFA1006-36S37-XXX | HFA412-2S38-XX |
| Brand | HELIAX® FiberFeed® | HELIAX® FiberFeed® | HELIAX® FiberFeed® |
| Center Conductor Gauge | 6 AWG | 6 AWG | 12 AWG (8 AWG equivalent) |
| Conductors, quantity | 6 | 10 | 4 (2 AWG equivalent) |
| Total Fiber Quantity | 24 | 36 | 2 |
| Armor Type | Corrugated aluminum | Corrugated aluminum | Corrugated aluminum |
| Fiber Type | TeraSPEED® Singlemode fiber | TeraSPEED® Singlemode fiber | TeraSPEED® Singlemode fiber |
| Alarm Wire (Qty Gauge) | 2 18 AWG | 2 18 AWG | N/A |

Dimensions

| | | | |
|-------------------------------|-----------|------------|-----------|
| Cable Weight | .97 lb/ft | 1.42 lb/ft | .16 lb/ft |
| Diameter Over Jacket | 1.2 in | 1.39 in | .51 in |
| Breakout Length, Fiber, end 1 | 32.5 in | 32.5 in | 13 in |
| Breakout Length, Power, end 1 | 24 in | 24 in | 42 in |
| Breakout Length, Fiber, end 2 | 32.5 in | 32.5 in | 18 in |
| Breakout Length, Power, end 2 | 24 in | 24 in | 18 in |

Physical Specifications

| | | | |
|-----------------------------------|---------|----------|---------|
| Minimum Bend Radius, loaded | 24 in | 27.9 in | 10 in |
| Minimum Bend Radius, unloaded | 12 in | 13.9 in | 5.1 in |
| Tensile Load, long term, maximum | 240 lbf | 450 lbf | 90 lbf |
| Tensile Load, short term, maximum | 800 lbf | 1500 lbf | 300 lbf |

General Specifications (continued)

| | | | |
|--------------------------|-----------------------------|-----------------------------|-----------------------------|
| Cable Type | HFA412-4S38-XX | HFA412-6S38-XX | HFA412-4S39-XX |
| Brand | HELIAX® FiberFeed® | HELIAX® FiberFeed® | HELIAX® FiberFeed® |
| Center Conductor Gauge | 12 AWG (8 AWG equivalent) | 12 AWG (8 AWG equivalent) | 12 AWG (8 AWG equivalent) |
| Conductors, quantity | 4 (2 AWG equivalent) | 4 (2 AWG equivalent) | 4 (2 AWG equivalent) |
| Total Fiber Quantity | 4 | 6 | 4 |
| Armor Type | Corrugated aluminum | Corrugated aluminum | Corrugated aluminum |
| Fiber Type | TeraSPEED® Singlemode fiber | TeraSPEED® Singlemode fiber | TeraSPEED® Singlemode fiber |
| Alarm Wire (Qty Gauge) | N/A | N/A | N/A |

Dimensions

| | | | |
|-------------------------------|-----------|----------|-----------|
| Cable Weight | .16 lb/ft | .2 lb/ft | .16 lb/ft |
| Diameter Over Jacket | .51 in | .57 in | .51 in |
| Breakout Length, Fiber, end 1 | 13 in | 13 in | 30 in |
| Breakout Length, Power, end 1 | 18 in | 18 in | 18 in |
| Breakout Length, Fiber, end 2 | 42 in | 42 in | 42 in |
| Breakout Length, Power, end 2 | 18 in | 18 in | 18 in |

Physical Specifications

| | | | |
|-----------------------------------|---------|---------|---------|
| Minimum Bend Radius, loaded | 10 in | 11.4 in | 10 in |
| Minimum Bend Radius, unloaded | 5.1 in | 5.7 in | 5.1 in |
| Tensile Load, long term, maximum | 90 lbf | 90 lbf | 90 lbf |
| Tensile Load, short term, maximum | 300 lbf | 300 lbf | 300 lbf |

General Specifications (continued)

| | | | |
|-----------------------------------|-----------------------------|-----------------------------|-----------------------------|
| Cable Type | HFA412-6S39-XX | HFA412-4S40-XX | HFA412-6S40-XX |
| Brand | HELIAX® FiberFeed® | HELIAX® FiberFeed® | HELIAX® FiberFeed® |
| Center Conductor Gauge | 12 AWG (8 AWG equivalent) | 12 AWG (8 AWG equivalent) | 12 AWG (8 AWG equivalent) |
| Conductors, quantity | 4 (2 AWG equivalent) | 4 (2 AWG equivalent) | 4 (2 AWG equivalent) |
| Total Fiber Quantity | 6 | 4 | 6 |
| Armor Type | Corrugated aluminum | Corrugated aluminum | Corrugated aluminum |
| Fiber Type | TeraSPEED® Singlemode fiber | TeraSPEED® Singlemode fiber | TeraSPEED® Singlemode fiber |
| Alarm Wire (Qty Gauge) | N/A | N/A | N/A |
| Dimensions | | | |
| Cable Weight | .2 lb/ft | .16 lb/ft | .2 lb/ft |
| Diameter Over Jacket | .57 in | .51 in | .57 in |
| Breakout Length, Fiber, end 1 | 30 in | 30 in | 30 in |
| Breakout Length, Power, end 1 | 18 in | 18 in | 18 in |
| Breakout Length, Fiber, end 2 | 42 in | 42 in | 42 in |
| Breakout Length, Power, end 2 | 18 in | 18 in | 18 in |
| Physical Specifications | | | |
| Minimum Bend Radius, loaded | 11.4 in | 10 in | 11.4 in |
| Minimum Bend Radius, unloaded | 5.7 in | 5.1 in | 5.7 in |
| Tensile Load, long term, maximum | 90 lbf | 90 lbf | 90 lbf |
| Tensile Load, short term, maximum | 300 lbf | 300 lbf | 300 lbf |

General Specifications (continued)

| | | |
|-----------------------------------|-----------------------------|-----------------------------|
| Cable Type | DFJ-4S010-XX | DFJ-6S010-XX |
| Brand | HELIAX® FiberFeed® | HELIAX® FiberFeed® |
| Total Fiber Quantity | 4 | 6 |
| Armor Type | Corrugated steel | Corrugated steel |
| Fiber Type | TeraSPEED® Singlemode fiber | TeraSPEED® Singlemode fiber |
| Dimensions | | |
| Cable Weight | .14 lb/ft | .14 lb/ft |
| Diameter Over Jacket | 0.59 in | 0.59 in |
| Breakout Length, Fiber, end 1 | 30 in | 30 in |
| Breakout Length, Fiber, end 2 | 42 in | 42 in |
| Physical Specifications | | |
| Minimum Bend Radius, loaded | 8.8 in | 8.8 in |
| Minimum Bend Radius, unloaded | 5.9 in | 5.9 in |
| Tensile Load, long term, maximum | 180 lbf | 180 lbf |
| Tensile Load, short term, maximum | 607 lbf | 607 lbf |



WARNING: CommScope Hybrid FiberFeed® cables require the use of approved installation accessories.

**HFA412 (1 pair)
Hybrid Jumper**

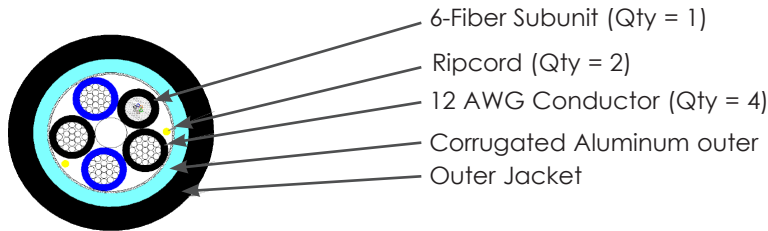

- 6-Fiber Subunit (Qty = 1)
- Ripcord (Qty = 2)
- 12 AWG Conductor (Qty = 4)
- Corrugated Aluminum outer
- Outer Jacket

**HFT606 (3 pair)
Low Capacity**

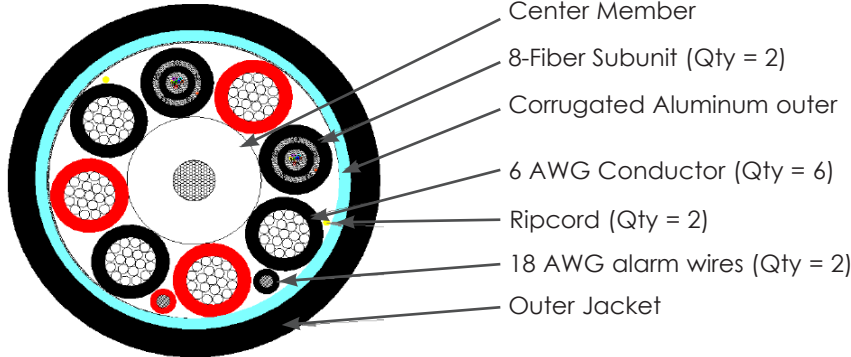

- Center Member
- 8-Fiber Subunit (Qty = 2)
- Corrugated Aluminum outer
- 6 AWG Conductor (Qty = 6)
- Ripcord (Qty = 2)
- 18 AWG alarm wires (Qty = 2)
- Outer Jacket

**HFT1006 (5 pair)
High Capacity**

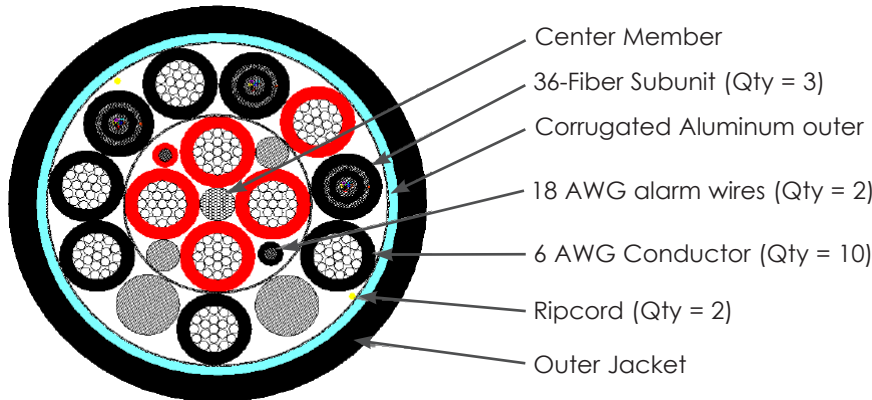

- Center Member
- 36-Fiber Subunit (Qty = 3)
- Corrugated Aluminum outer
- 18 AWG alarm wires (Qty = 2)
- 6 AWG Conductor (Qty = 10)
- Ripcord (Qty = 2)
- Outer Jacket

Jumper Assemblies

- In general this cable will handle similarly to a 1/2" coaxial cable.
- The terminated fiber ends however are fragile and must be protected during installation. Leave the packaging around the fiber ends in place until ready to connect the jumper between OVP box and RRU or BBU.
- DO NOT BEND THE FIBER ENDS (in the furcation tubes) TIGHTER THAN 1.2" (30mm) BEND RADIUS ELSE THERE IS A RISK OF BREAKING THE GLASS FIBERS.
- Attach the main cable securely to the structure or equipment using hangers and/or cable ties to prevent strain on connections from movement in wind or snow/ice conditions.
- Ensure the LC fiber connectors are seated firmly in the OVP box, RRU or in BBU equipment.
- Ensure the weatherproof boots for both fiber and power connections and seated firmly in the RRU.
- Heat shrink tube of the jumper should be 1" (25.40mm) inside of the OVP box.
- Installation temperature range is -22F to 158F (-30C to 70C).
- Minimum cable bend radii can be found in this document or on-line.
- Standard lengths available are 3-6-15 foot for top tails and 3-6-15-20 foot for bottom tails.
- All jumpers are individually serialized, for immediate access to test results visit www.commscope.com/webtrak/
- Power connector is supplied with the RRU
- Blue or Red power conductor is 48V
- Black power conductor is 0V

HFA412-4S38 Hybrid tails, 4 Fibers (FRIG)

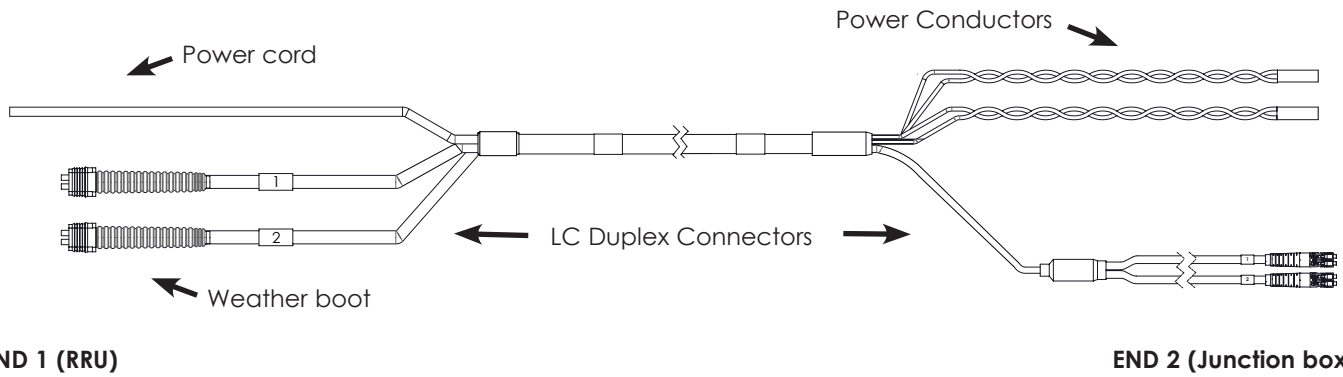

HFA412-4S39 Hybrid tails, 4 Fibers (FRIE / FXFB)

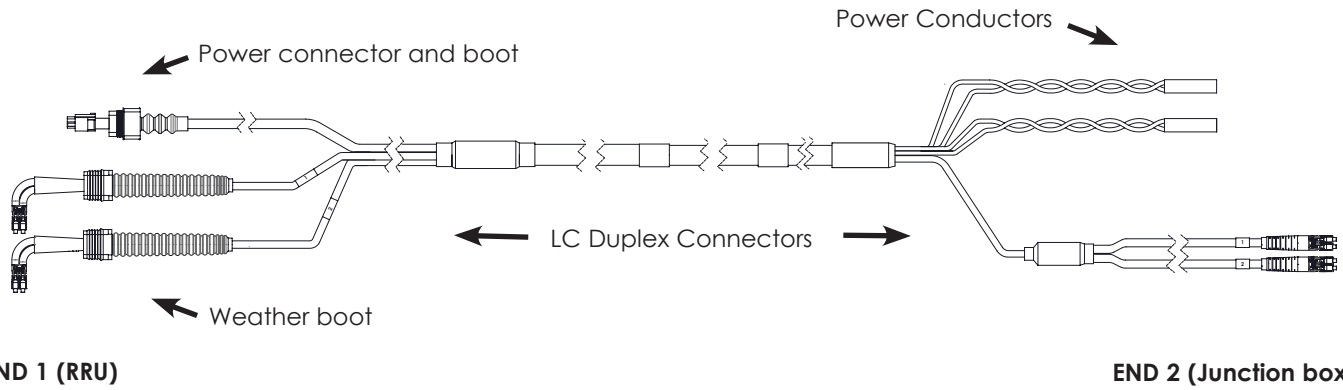

HFA412-4S40 Hybrid tails, 4 Fibers (FXFC)

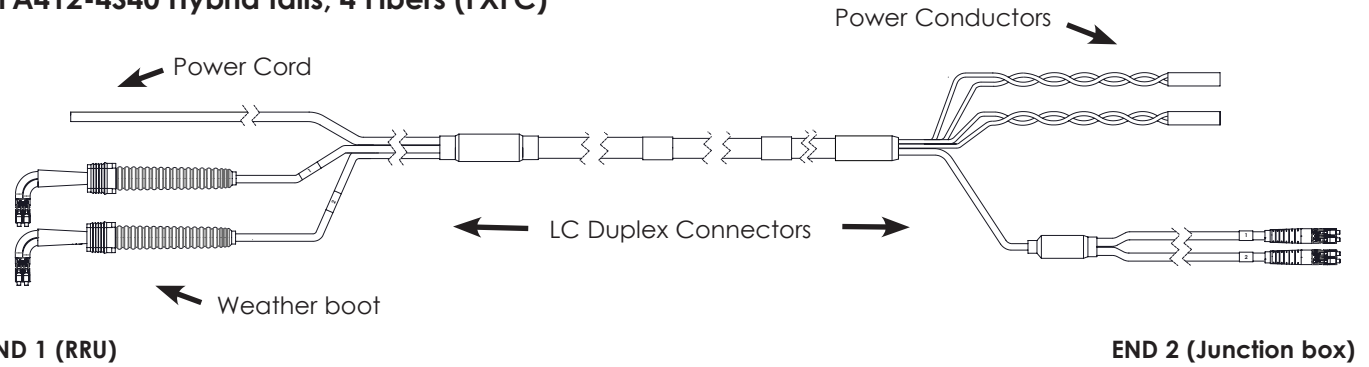

DFJ-4S010 fiber tails, 4 Fibers

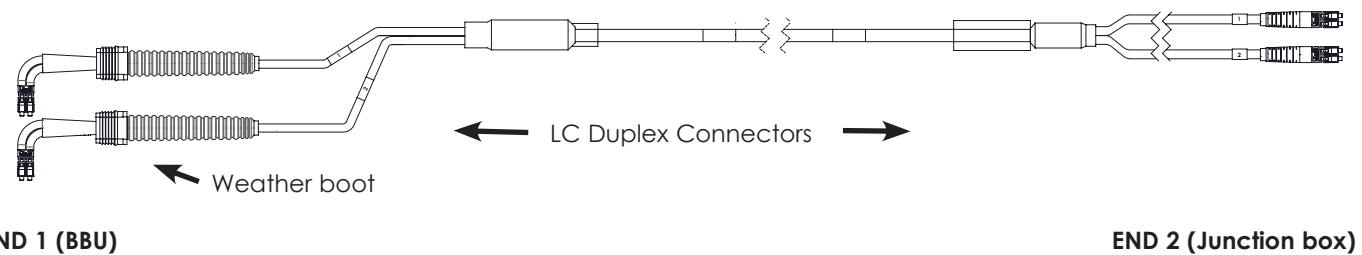

Trunk Fiber Feeder

- In general this cable will handle similarly to 7/8" coaxial cable, and similar installation techniques apply. All cables are individually serialized, be sure to write down the cable serial number for future reference.
- The terminated fiber ends (the broken out fibers plus connectors) however are fragile, and these must be protected during the installation process.
- Leave the protective tube and sock around the fiber tails and connectors in place during hoisting and securing the cable. Remove this only just prior to making the final connections to the Junction box.
- DO NOT BEND THE FIBER ENDS (in the furcation tubes) TIGHTER THAN 1.2" (30mm) BEND RADIUS ELSE THERE IS A RISK OF BREAKING THE GLASS FIBERS.
- Be sure that the lace up ends and fiber connectors are not damaged by attachment of a hoisting grip or during the hoisting process. Attach a hoisting grip on the jacketed cable no less than 6" below the fiber breakout point. If a hoisting grip is not easily attached, use a simple line attached below the fiber break-out point (i.e. at the cable outer jacket). Prevent the fiber tails (in protective tube) at the cable end from undue movement during hoisting by securing the protective tube (with outer sock) to the hoisting line.
- During hoisting ensure that there is a free path and that the cable, and especially the fiber ends, will not be snagged on tower members or other obstacles.
- Installation temperature range is -22F to 158F (-30C to +70C).
- Minimum cable bend radii can be found in this document or on-line.
- Maximum cable tensile load can be found in this document or on-line.
- CommScope Lace-Up Hoisting Grip 19256B-C required for all installations.
- Maximum hanger spacing 3ft (0.9m) - 4ft (1.2m)

⚠ Hybrid Fiber Cables weigh more than traditional coaxial cables. Be sure to follow proper hoisting and attachment procedures.

Hoisting Recommendations

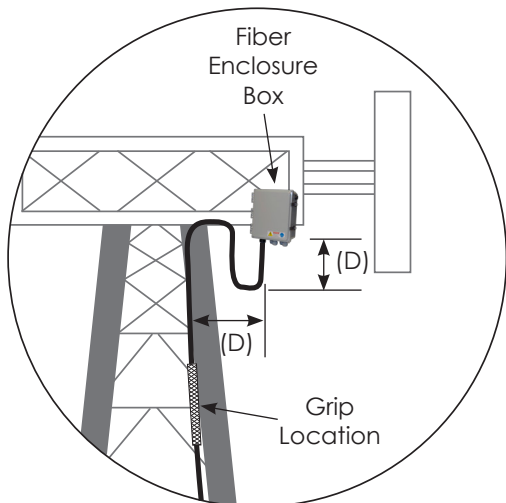

Reminder: Plan grip location by measuring distance (D) from Fiber Enclosure Box to tower support member.

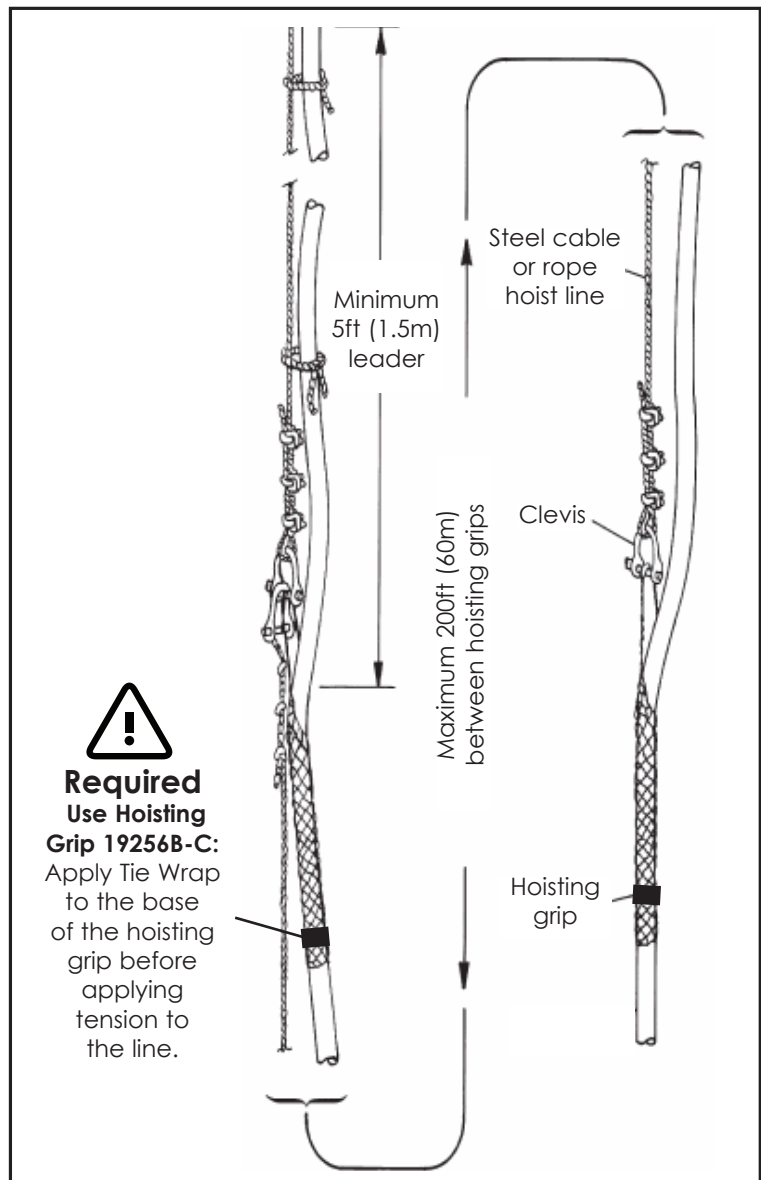

Breakout Procedure

After the trunk cable has been installed and you are ready to make the final connection to the OVP box follow these steps for the removal of fiber protection tube.



1 Remove electrical tape from the trunk cable and corrugated protection tube



2 While holding the protection tube straight pull the tube away from cable.



3 After you have pulled the fiber and power conductors into the OVP box remove electrical tape from the trunk cable and remove clear tube for access to all optical connectors.

LC Connectors and Adapter cleaning

Clean exposed connector ferrule by lightly moistening lint-free wipe with fiber optic cleaning solution (or >91% isopropyl alcohol), and by applying medium pressure, first wipe against wet area and then onto dry area to clean potential residue from end face. Clean connector ferrule inside adapter by inserting lightly moistened cleaning stick with fiber optic cleaning solution (or >91% isopropyl alcohol) inside the adapter until contact is made with connector on opposite end. Rotate cleaning stick with medium pressure in one circular motion as it is pulled away from the adapter. Repeat process using dry cleaning stick.

Caution: Signal strength will be affected if end and sides of ferrule are not thoroughly cleaned. Discard cleaning sticks after each use. Do not turn cleaning sticks back and forth pressing against connector end face. This may cause scratches if large contamination is present. Always inspect connector end face for contamination after each cleaning.

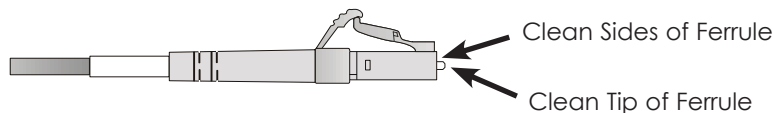

Clean adapter by inserting adapter cleaning stick (or fiber adapter sleeve brush) moistened with fiber optic cleaning solution (or >91% isopropyl alcohol) inside the adapter and gently pull out with twisting motion. Repeat process with a dry cleaning stick.

Caution: Do not try to clean adapter with a standard pipe cleaner. The sleeve inner diameter of LC adapters is too small. Do not try to clean the adapter with cleaning stick if a connector is mounted in one side. Discard cleaning sticks after each use.



All in one cleaner

Device designed for cleaning the ferrule end faces of LC connectors

Open guide cap, insert LC connector into guide, push the outer shell to start cleaning the LC connector interface, a "click" sound indicates end of a cleaning process, repeat, close cap immediately after use.

Caution: Be careful not to slant LC connector while inserting into the Guide cap. Do not overly exert force during insertion as this may cause damage to both the connector and the cleaner.

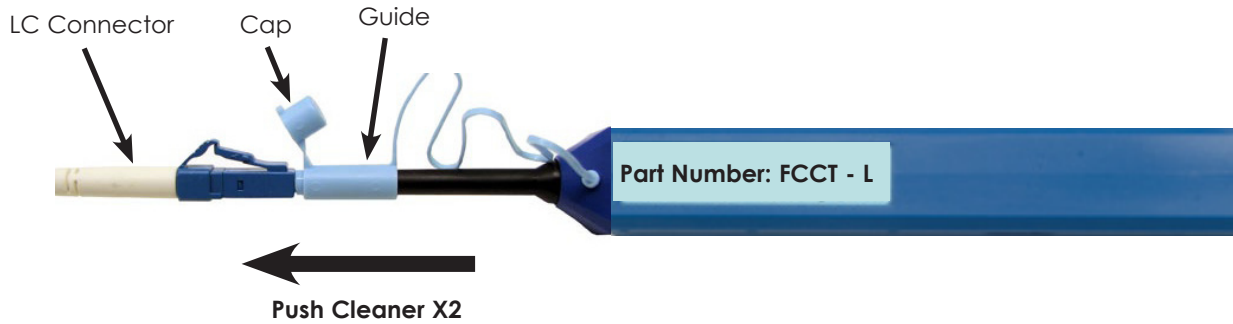

Inspecting

There are 3 basic principles that are critical to achieving an efficient fiber optic connection:

1. Perfect Core Alignment
2. Physical Contact
3. Pristine Connector Interface



Today's connector design and production techniques have eliminated most of the challenges to achieving core alignment and physical contact. What remains challenging is maintaining a pristine end-face. As a result, CONTAMINATION is the #1 reason for troubleshooting optical networks.

Implementing the process of cleaning and inspecting before mating can reduce the time spent troubleshooting, optimize signal performance and prevent damage.

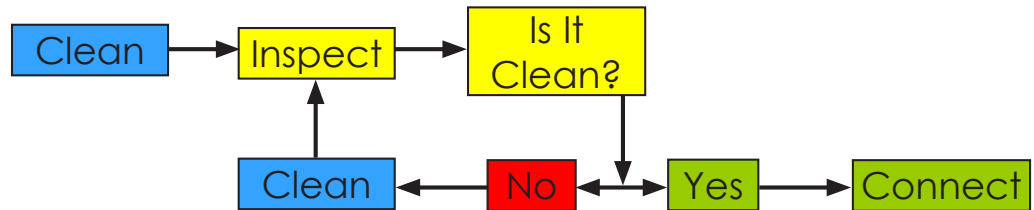

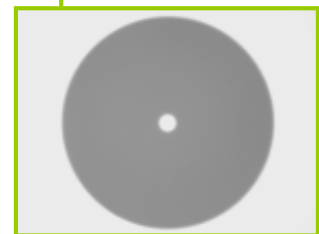
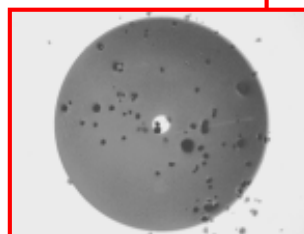

Abrasive particles (i.e. rock dust) can cause permanent damage to the interface. If interface is scratched it cannot be repaired, it would need to be replaced.



OVP Junction Box: RCMDC-4010-PF-48

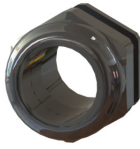
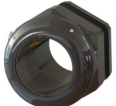
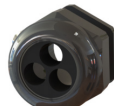

| Configuration | Entry Port 1 | Entry Port 2 | Entry Port 3 | Entry Port 4 | Entry Port 5 |
|-----------------------------|----------------------------------|--------------------------------|--------------------------------------|--------------------------------------|--------------------------------------|
| Tower / Top | HFT1006 Trunk - A | 3 HFA412 Jumpers - B | 2 HFA412 Jumpers - D | 2 HFA412 Jumpers - D | 2 HFA412 Jumpers - D |
| Tower / Bottom | 1-1/2 Conduit Fitting - G | HFT1006 Trunk - A | HFT606 Sector Trunk - C | DFJ-4S Fiber only Jumpers - E | DFJ-4S Fiber only Jumpers - E |
| Roof Top / Baseband on roof | 1-1/2 Conduit Fitting - G | HFT606 Sector Trunk - F | HFT606 Sector Trunk - C | HFT606 Sector Trunk - C | DFJ-4S Fiber only Jumpers - E |
| Water Tower / Top | Not Used | HFT1006 Trunk - A | HFT606 Sector Trunk - C | HFT606 Sector Trunk - C | HFT606 Sector Trunk - C |
| Water Tower / Bottom | 1-1/2 Conduit Fitting - G | HFT1006 Trunk - A | DFJ-4S Fiber only Jumpers - E | DFJ-4S Fiber only Jumpers - E | Not Used |

| | | | |
|--|---|--|---|
| <p>A M50 Gland HFT1006 Trunk</p>  | <p>B M50 gland insert with 3 holes for HFA412 Jumper</p>  | <p>C M40 Gland HFT606 Sector Trunk</p>  | <p>D M40 gland insert with 2 holes for HFA412 Jumper</p>  |
| <p>E M40 gland with 3 holes DFJ-4S Fiber only Jumpers</p>  | <p>F M40 Gland for HFT606 Sector Trunk</p>  | <p>G 1-1/2 Conduit Fitting</p>  | |

OVP Junction Box Wiring: RCMDC-4010-PF-48

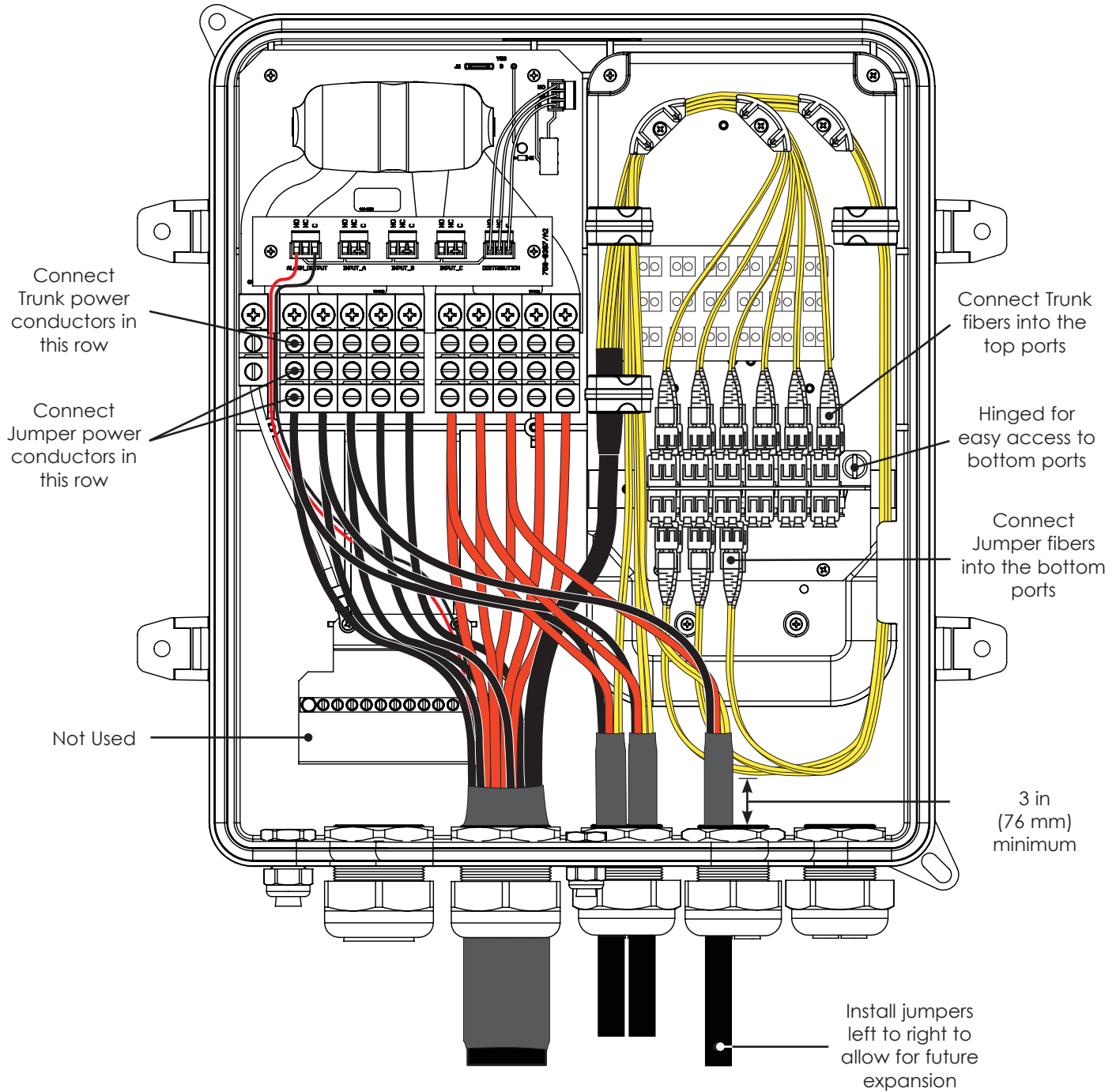

Drawing shown with Qty 1: HFT606-24S37 series trunk and Qty 3: HFA412-4S-39 series jumpers

OVP Junction Box: RNSNDC-7771-PF-48



| Config. | Entry Port 1 | Entry Port 2 | Entry Port 3 | Entry Port 4 | Entry Port 5 | Entry Port 6 | Entry Port 7 | Entry Port 8 | Entry Port 9 |
|-----------------------------|------------------|---------------------------|---------------------------|---------------|--------------|--|--|--|------------------|
| Tower / Top | 1 HFA412 Jumpers | 1 HFA412 Jumpers | 1 HFA412 Jumpers | HFT1006 Trunk | Not Used | 3 HFA412 Jumpers | 1 HFA412 Jumpers | 1 HFA412 Jumpers | 1 HFA412 Jumpers |
| Tower / Bottom | Power - A | Optional Power - A | Optional Power - A | HFT1006 Trunk | Not Used | 9 DFJ-4S Fiber only Jumpers - B | Optional Power - A | Not Used | Not Used |
| Roof Top / Baseband on roof | Power - A | Optional Power - A | Optional Power - A | HFT606 Trunk | HFT606 Trunk | HFT606 Trunk | 3 DFJ-4S Fiber only Jumpers - C | 3 DFJ-4S Fiber only Jumpers - C | Not Used |
| Water Tower / Top | Not Used | Not Used | HFT606 Trunk | HFT1006 Trunk | HFT606 Trunk | HFT606 Trunk | Not Used | Not Used | Not Used |
| Water Tower / Bottom | Power - A | Optional Power - A | Optional Power - A | HFT1006 Trunk | Not Used | 9 DFJ-4S Fiber only Jumpers - B | Optional Power - A | Not Used | Not Used |

| | | |
|---|--|---|
| <p>A 1-1/4 Conduit Fitting</p>  | <p>B M63 gland insert with 9 holes for DFJ-4S Fiber Jumpers</p>  | <p>C 1-1/4 " or 1" NPT gland insert with 3 holes for DFJ-4S Fiber Jumpers</p>  |
|---|--|---|



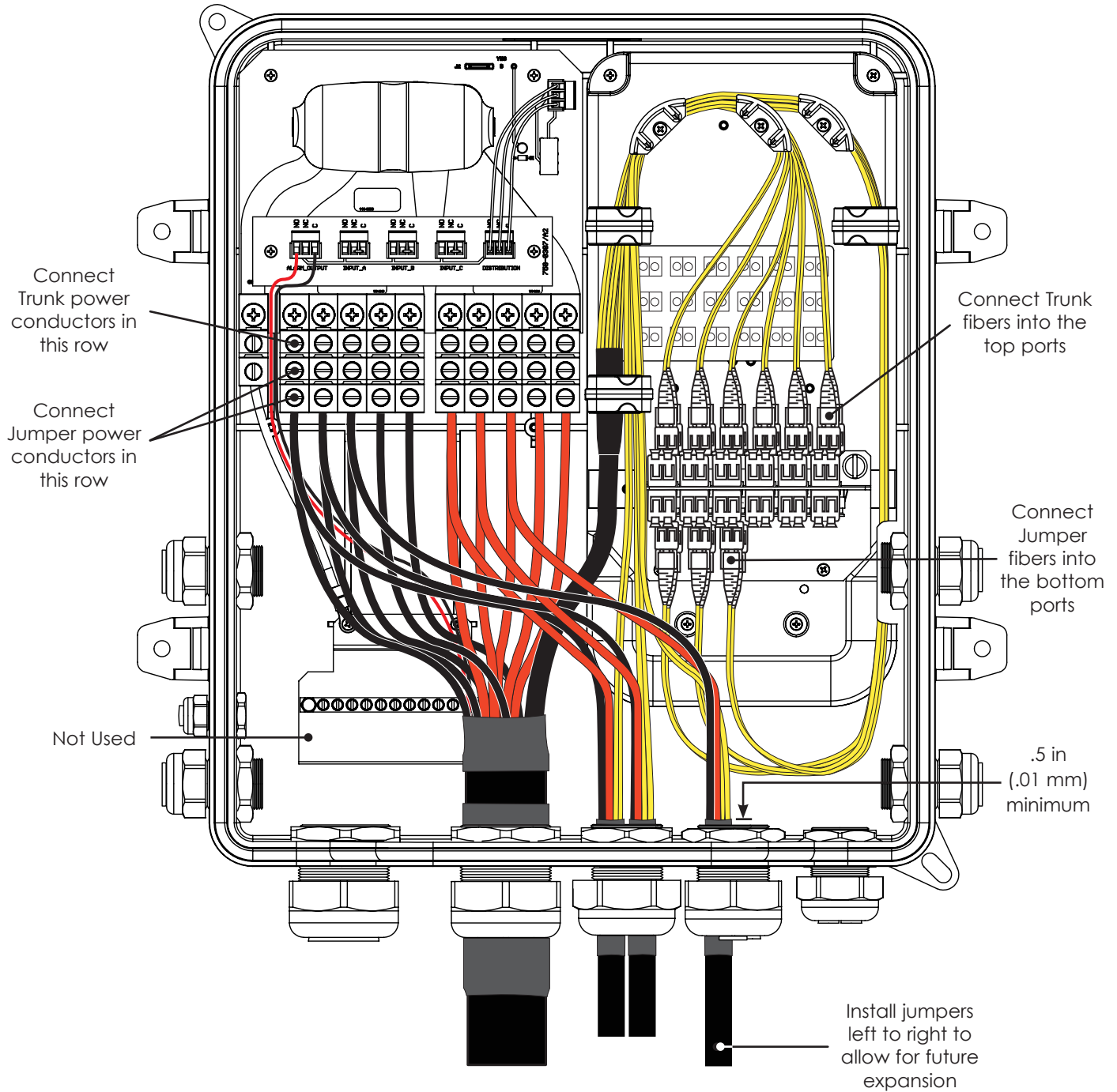





OVP Junction Box Wiring: RNSNDC-4010-PF-48

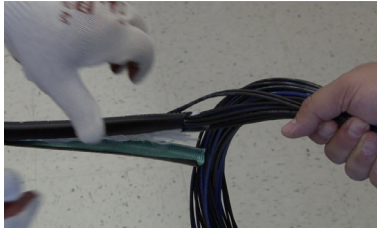

Drawing shown with Qty 1: HFT606-24S37 series trunk and Qty 3: HFA412-4S-39 series jumpers

Excess Cable Management

If length of cable installed needs to be adjusted you can split the cable at the BBU end using the process below and then coiling the excess fiber subunits in a storage box. Fiber management trays are available to manage any excess fiber length in the breakouts at the BBU.

| | |
|--|---|
| <p>1. Mark cutback length</p>  | <p>2. Notch armor using flush cutter in-line with Kevlar strings</p>  |
| <p>3. Place rip cord in notches'</p>  | <p>4. Pull rip cord parallel to cable (while supporting breakout)</p>  |
| <p>5. Stop at length marker</p>  | <p>6. Separate armor</p>  |
| <p>7. Cut armor using side cutter</p>  | <p>8. Remove water blocking tape</p>  |
| <p>9. Remove excess rip cord</p>  | <p>10. Apply electrical tape to protect breakout</p> <p>NOTE: Remember to slide identifier labels down the power conductors before trimming the cable to it's final length</p>  |



Excess Fiber storage Box
Part Number:
FE-14126-E



Fiber management tray, Part Number:
Fe-14192-IR



Scan to view video



Click here for video

Maintenance Check List

HFT Trunks

- Hangers and grommets securely fastened
- No damage to cable jacket
- Grounding kits securely connected and weatherproofing intact
- Labels securely attached

Junction Boxes

- Box mounting secure
- All electrical terminals secure
- All fiber connections seated correctly
- All cable entry glands tight and cables secure
- Box securely latched closed using all latches

HFA Jumpers

- All jumper supports secure
- No damage to cable jacket
- Weatherproofing intact where installed
- RRU connection cover secure
- RRU DC and fiber connections secure and seated properly

Fiber Troubleshooting

- Visually inspect end face for residual dirt and damage
- Clean all connector end faces with appropriate All in One cleaner.
- Avoid migration of contaminations from one connector to another
- Check continuity by using LED or laser light source from one end face and look for light from other end to identify any broken fiber (Do not look directly at cable with laser source)
- Check end face again for cleanliness before attachment. If needed, clean again
- Scan QR code to visit Webtrak online for fast, easy access to test data or download the cTrak app from www.commscope.com/apps



CommScope

1100 CommScope Place SE P.O. Box 339, Hickory, NC 28603-0339
 (828) 324-2200 (800) 982-1708
www.commscope.com/andrew

Customer Service 24 hours

North America: +1-800-255-1479 (toll free)
 Any country: +1-779-435-6500
 email: acicustomersupportcenter@commscope.com

Notice: CommScope disclaims any liability or responsibility for the results of improper or unsafe installation, inspection, maintenance, or removal practices.
 Aviso: CommScope no acepta ninguna obligación ni responsabilidad como resultado de prácticas incorrectas o peligrosas de instalación, inspección, mantenimiento o retiro.
 Avis : CommScope décline toute responsabilité pour les conséquences de procédures d'installation, d'inspection, d'entretien ou de retrait incorrectes ou dangereuses.
 Hinweis: CommScope lehnt jede Haftung oder Verantwortung für Schäden ab, die aufgrund unsachgemäßer Installation, Überprüfung, Wartung oder Demontage auftreten.
 Atenção: A CommScope abdica do direito de toda responsabilidade pelos resultados de práticas inadequadas e sem segurança de instalação, inspeção, manutenção ou remoção.
 Avvertenza: CommScope declina eventuali responsabilità derivanti dall'esecuzione di procedure di installazione, ispezione, manutenzione e smontaggio improprie o poco sicure.

注意: CommScope 公司申明對於不恰當或不安全的安裝、檢驗、維修或拆卸操作所導致的後果不負責任 何義務和責任

© 2014 CommScope