

Sigma-Link Quick-Fit Cable Assembly

1. INTRODUCTION

This specification describes the assembly procedure for **Sigma-Link Quick-Fit pre-terminated cable bundle**. Read these instructions thoroughly before starting installation.

2. DESCRIPTION

Sigma-Link Quick-Fit Cable Assemblies are designed to be installed into Universal Connectivity Panel (UCP), part numbers 1-1671590-1 or 1-1671594-0, according to Instruction Sheet 411-117007 (UCP Panel).

The patch panels are designed to be mounted onto a standard 19-inch Electronics Industries Alliance (EIA) rack or equipment cabinet.

3. REFERENCE DOCUMENTS DESCRIPTION

CommScope drawings are available from the CommScope network. The information contained in customer and product drawings takes priority if there is any conflict with this specification or with any other technical documentation supplied by CommScope.

Instr. sheet (UCP Panel)	Packaging spec. (specific.)	Packaging spec. (general for labelling)	Instr. Sheet (Jack/Plug)	Process spec.	QC doc.
411-117007	107-117011	107-93008	Refer to section 4.1	118-93014 / 118-93016 (*)	108-117000

4. ASSEMBLY INSTRUCTION

4.1. Termination Guidelines

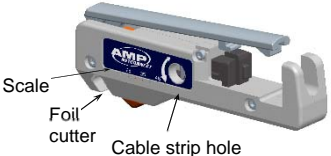
(Depending on the connector to be used)					
System	Performance	Product PN	Instruction Sheet	Termination tool	Tool view (for ref. only)
STP	Class FA-PL	Jack 1711437-1	411-93013	1725150-1	
STP	Class EA-PL	Jack 1711716-1	411-93016	1725150-1	
UTP	Class EA-PL	Jack 1933476-2	408-10470	1725150-1	
UTP	Class E-PL	Jack 1933748-2	408-8858	1725150-1	
STP(*)	Class EA-PL	Mod. Plug 1499598-1 / Boot 1933943-1	118-93037	Sentinel® Hand tool ref. 900019	





Cable assembly lengths according to drawing PN **1671314**; 0-PN-2 to 9-PN-9 meaning from 2 to 99 meters.
(*) Specifically for "Consolidation Points".

4.2. Product Versions

(Depending on configuration type)				
Configuration type / System	"Housing" to "Housing" with POF	"Housing" to Jack	"Housing" to Open end	"Housing" to Plug (*)
STP - Class FA-PL	X	X	X	--
STP - Class EA-PL	X	X	X	X
UTP - Class EA-PL	X	X	X	--
UTP - Class E-PL	X	X	X	--

4.3. Assembly Instruction

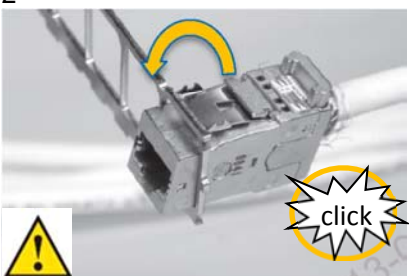
(Pictures shown are for reference only)

<p>1</p>   <p>Connectors have been terminated according to paragraph 4.1.</p> <p>Perform 100% Fluke testing for each single element before assembly jacks into metal frame (According to process spec.- section 3 -)</p> 	<p>2</p>   <p>Assembly Jacks into "metal frame" by means of pivoting the jack while pushing it toward the bottom to allow the "top latch" to enter into the "top rib" of the metal frame...</p> <p>("Click" is the conformity sign)</p>	<p>3</p>   <p>This is the "sub-assy metal frame".</p> <p>Add "number ID labels" for each individual cable. Refer to relevant product drawing.</p> <p>Strain relief must clamp on braid and cable jacket.</p>  <p>(The metal mesh should be covered by the "number ID labels").</p>
<p>4</p>  <p>- "POF" preparation- Strip the Plastic jacket of the Optical Fiber</p>	<p>5</p>   <p>Apply LOCTITE instant adhesive to one of the substrates to be bonded.</p>	<p>6</p>   <p>Insert the "POF" through hole and hold firmly by hand for about 30 s. until fixture.</p>



(table continued)

7



Handling strength is achieved within a few minutes.

8

NOTE  

Allow up to 24 h. for full bond strength to develop. Use in well ventilated areas. Avoid use of naked flames or other sources of ignition.

9

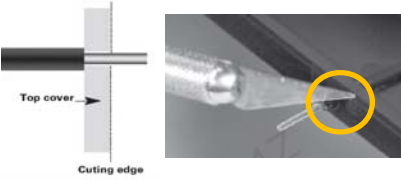

Cut "POF" with a hot knife



10



Pre-insert the "sub-assy. metal frame" (as shown in fig.3) into the "holder".

11

The "4 bottom tabs" of the metal frame has to fit into "4 slots of the holder" (this will be the rotation



NOTE 

edge)

12



Once pre-inserted, pivot the "sub-assy metal frame" while pushing it toward the "top surface" of the holder

...

13

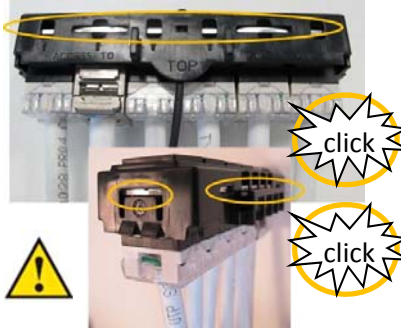

...to allow the "metal frame sub-assy. profile" to enter into the holder slots. ("Click" is the conformity sign).



14



(Repeat this process - depending on the configuration type - on both ends of the cable assembly. **Refer to paragraph 4.2).**

Once "cassettes" are already available is time to...

15



...assembly the "grounding spring clip" into the "Front Cover"...



16

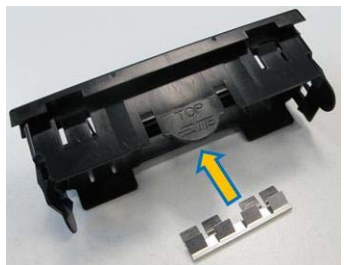

...by means of sliding the spring clip into the right slot on "Front Cover" (back side/bottom area).

17



NOTE  





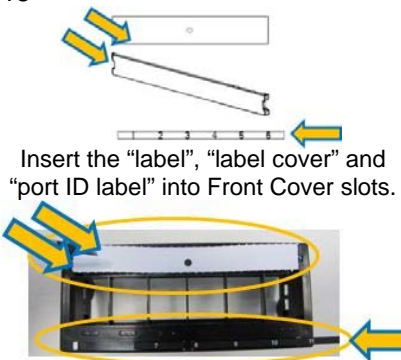

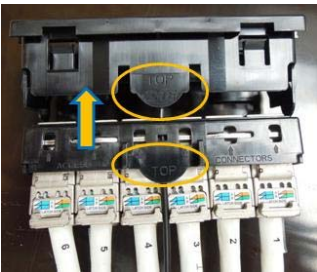

Ensure that spring is right placed & oriented

18

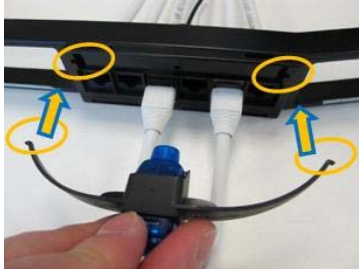

Insert the "label", "label cover" and "port ID label" into Front Cover slots.

(table continued)

<p>19</p>  <p>Insert and press in the "cassette" into the Front Cover.</p>	<p>20</p>  <p>Once the "cassette" is completely inserted into the "Front Cover", then two side latches should remain fixed. ("Click" is the conformity sign).</p>	<p>21</p> <p>NOTE</p>  <p>When "POF" is used (if any), perform lighting test check (100%) by using the "light identifier" device (or other method approved by Engineering)</p> 
<p>22</p>  <p>Switch on the "light" and check that on other "end cassette" light is viewable</p> 	<p>23</p> <p>NOTE</p>   <p>Cables shall be bundled using approved taping method. (view shown as reference only)</p>	<p>24</p>  <p>Cable bundle is finished and ready to be packed. (Black tape for reference only). (Refer to packaging specs. shown on section 3.)</p>

4.4. Disassembly Instruction: Cassette

(Cassette from Front Cover)

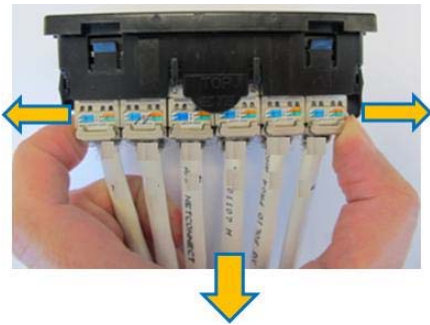
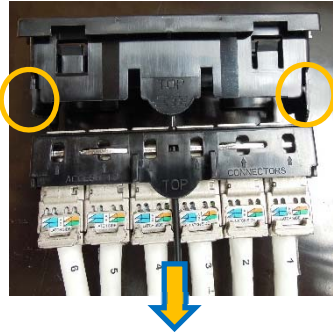
<p>1</p>  <p>Detail of "Side tabs" to allow unlocking process (disassembly "cassette" from "Front Cover")</p>	<p>2</p>  <p>Press laterally out the "Side tabs" with the fingers (as shown) at same time that hand is pushing back the "cable bundle" to allow unlocking "cassette" from "Front Cover".</p>	<p>3</p>  <p>"Cassette" is completely out from "Front Cover".</p>
--	--	--

4.5. Disassembly Instruction: Jack

(Individual Jack from Cassette)

1

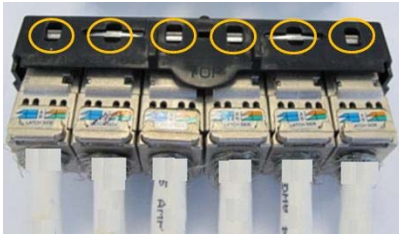

"Cassette" is populated with Jacks. In order to remove one specific jack from "cassette", you can use the help of related "top openings" to ...

2

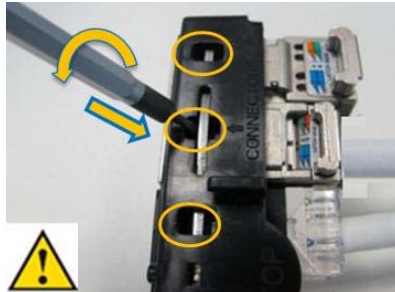

...insert the screwdriver through the selected opening and press the "jack latch" at same time that rotates it...

3

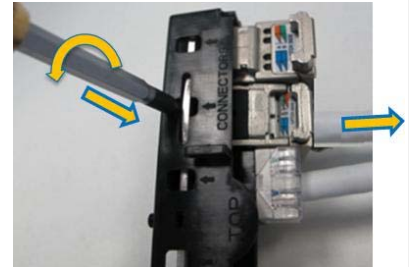

...then, jack is unlocked from metal frame...

4

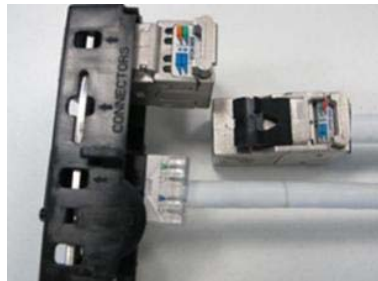

...by pushing back the cable.... The single cable assembly is completely out.

5. INSTALLATION PROCEDURE

For installation of **Sigma-Link Quick-Fit Cable Assemblies** into Universal connectivity Panel (UCP), please refer to Instruction Sheet 411-117007 (UCP Panel).

6. REVISION SUMMARY

This paragraph is reserved for a revision summary of changes and additions made to this specification.

- Updated format and Company name.