

## OneBase<sup>®</sup> Dual Band and Twin TMA ETT19V2S12UB/ETW200VS12UB/ETW190VS12UB



### INTRODUCTION

Andrew OneBase<sup>®</sup> Tower Mounted Amplifiers (TMA) enhance the uplink/reverse RF performance by improving the sensitivity of the base station receiver, extending the “talk back” range for subscriber transmitters operating in the base station receive band.

TMA's are installed near the receive antenna to eliminate signal degradation resulting from feeder loss.

There are two ports in the TMA. Dual band TMA supports (PCS/AWS) shown in Figure 1. Twin TMA supports same band (PCS or AWS) shown in Figure 2. In addition, it supports AISG and daisy-chained AISG RET.

Some benefits of using TMA's include:

- increased coverage area
- improved signal quality
- fewer dropped calls in fringe areas and inside buildings
- extended battery life in handheld terminals

### PRODUCT DESCRIPTION

Refer to Figure 3 for block diagrams of the TMA's.

The fully integrated, weatherproof TMA contains filters, AISG, low noise amplifier(s) (LNA), CPU and a DC bias tee. It amplifies each port separately and passes RET signals through the AISG port.

DC supply power to the LNA is provided through the RF feeder from the base station and is recovered in the bias tee. The LNA includes a bypass switch to ensure continued operation with reduced sensitivity in case of DC power removal.

TMA also support DC switching which allows uninterrupted DC supply in case of DC supply failure on one port.

AISG remote firmware upgrade is supported.

TMA can operate in either current mode (no AISG) or in AISG mode. Both modes support VSWR and TMA alarms reporting.

Lightning protection for the antenna port consists of a low frequency path to ground while at the BTS port, a Surge Suppression Circuit is integrated with the bias tee.

### RELATED EQUIPMENT

To complete your TMA system, you may need the following additional equipment:

1. Bias Tee to inject DC supply power on the RF feeder. For AISG controller, it might require a smart bias-tee or AISG compatible bias-tee.
2. Power Distribution Unit to condition and monitor the DC supply power and or AISG controller either from third-party or from OEM vendor which provides AISG functionality and supplies DC.

Contact your Andrew Solutions Sales Representative for recommendations on applicable system components.

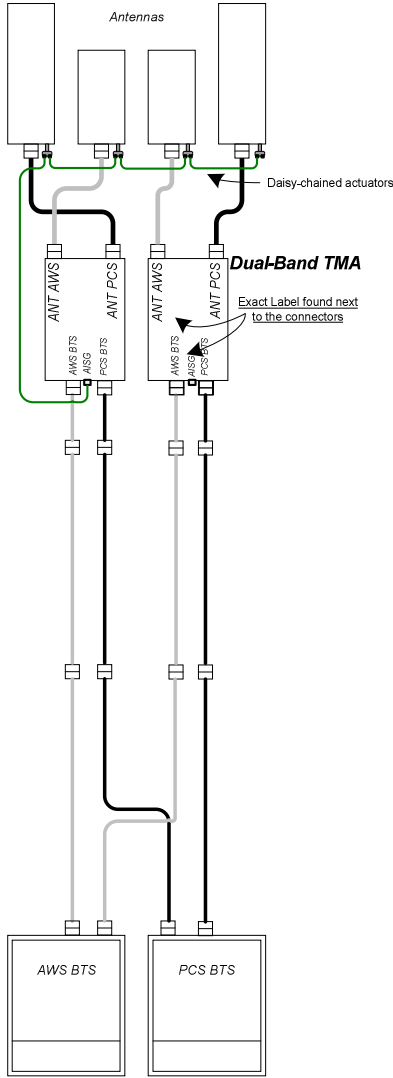

Figure 1 – Dual Band TMA Connections

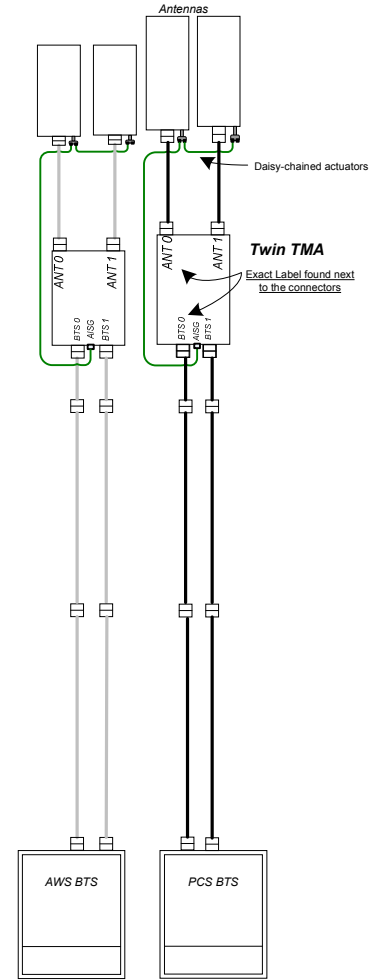

Figure 2 - Twin TMA Connections

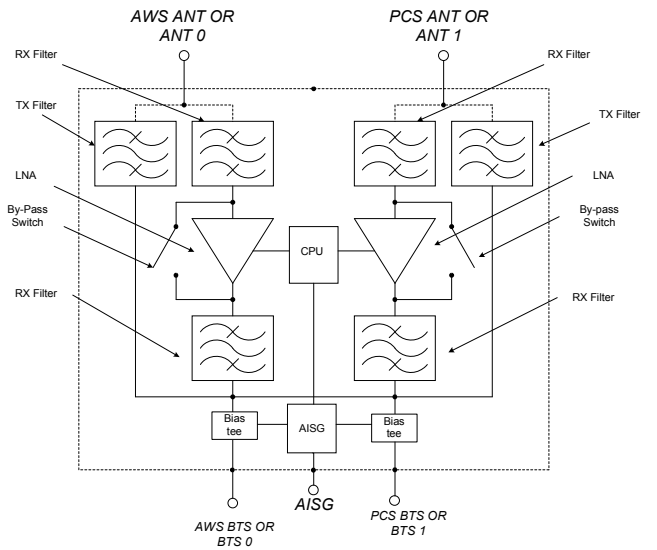

Figure 3 – TMA Block Diagram

**BEFORE INSTALLATION**

---

1. The TMA is designed to withstand the rigors of operation in an outdoor environment. While handling the TMA, take necessary steps to protect it from dents and scrapes that may compromise its durability. Keep dirt and moisture away from the connector interfaces.
2. Ensure that transmit power in each band is within the average and peak power ratings for the TMA.
3. Determine the installation location. Optimum sensitivity improvement is obtained when the TMA is installed as close as possible to the receive antenna.
4. Pole mounting hardware is supplied with the TMA. The unit can be mounted to a pole or tower member with a diameter up to 5.51 inches (140 mm). Mounting to a wall is also possible. Appropriate fasteners for the intended surface must be obtained separately.
5. Obtain appropriate jumper cables. To protect against connector damage, the TMA should be connected to the antenna and to the feeder with jumper cables ( $\frac{1}{2}$  inch recommended).
6. If AISG port is used, select the correct cable length.
7. Choose grounding method. A separate ground connection is advised. Andrew recommends 1m Ground Cable, part no. GND-1M or other 6-8 AWG copper wire.
8. Plan the installation. Inspect the equipment. Review the instructions. TMA has label that indicates which the side goes to the BTS and to the antenna. Ensure that needed tools and supplies are available, including cable ties, grounding hardware, and weather-sealing materials.



Figure 4 Assembling Pole Mount Hardware – Step 1.2

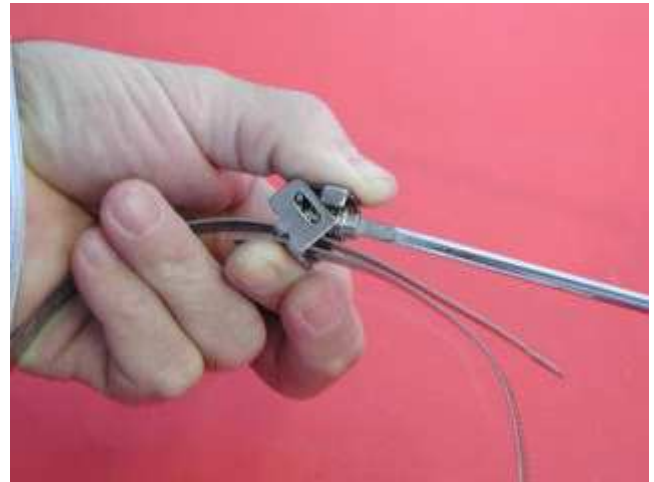

Figure 7 Assembling Pole Mount Hardware - Step 1.5

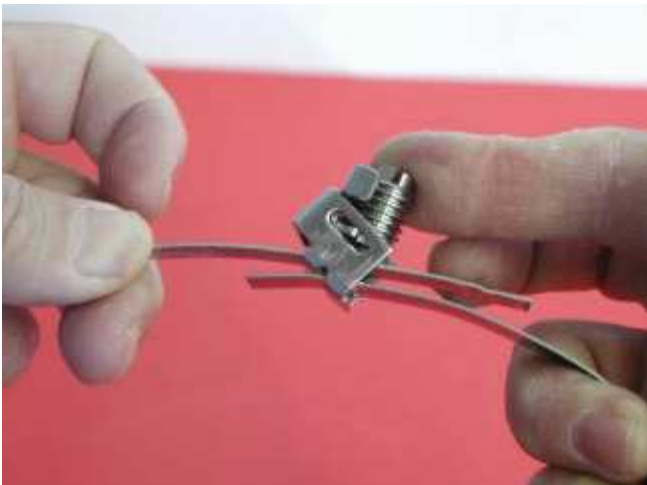

Figure 5 Assembling Pole Mount Hardware - Step 1.3

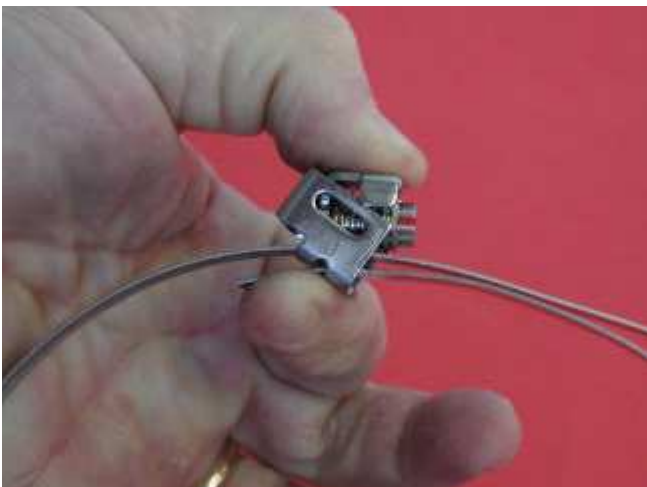

Figure 6 Assembling Pole Mount hardware – step 1.4

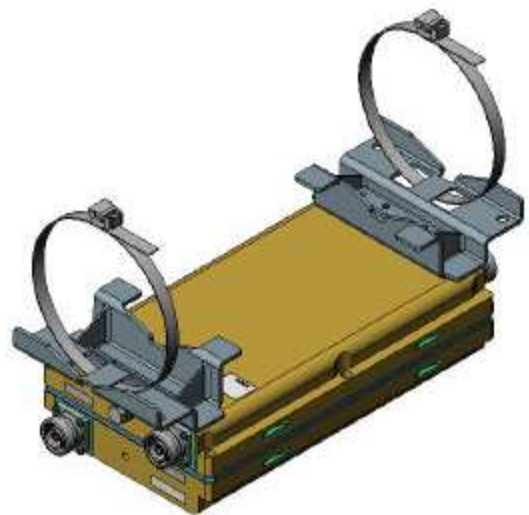

Figure 8 TMA with Pole Mount Hardware

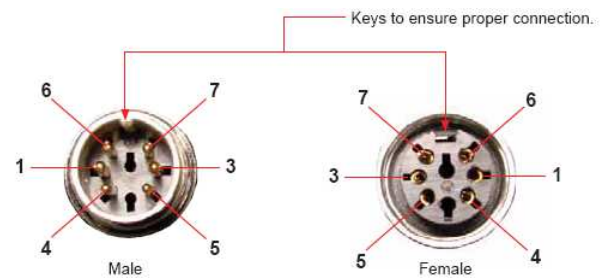

Figure 9 AISG Pins

## MOUNTING TO A POLE OR BEAM

---

1. TMA comes with pole mounting kit and mounting instructions. Assembling the pole mounting hardware as follows:
  - 1.1. Insert the band through the holes in the TMA brackets.
  - 1.2. Orient the TMA in the selected location with the BTS port pointing down marked on the TMA with **BTS** and Antenna port pointing up marked with **ANT**, or as required.
  - 1.3. Insert one terminal of the back into the lower slot of the buckle shown in Figure 4.
  - 1.4. Insert the other terminal of the back into the upper slot of the buckle as shown in Figure 5.
  - 1.5. Rotate the screw toward the band while pressing as shown in Figure 6.
  - 1.6. Tighten the screw along the band up to the required strength (max 5 Nm) by means of a screwdriver as shown in Figure 7.
  - 1.7. Repeat on the other side of the TMA. Figure 8 shows the assembled mounting hardware with TMA.
2. Attach a ground cable to the TMA using the pre-installed hex bolt and washers. Route the ground cable to the ground bar on the tower structure and attach securely with suitable fastener.
3. Route cables as follows:
  - 3.1. Route a jumper cable from the AWS antenna port to the TMA port marked "ANT AWS" for dual band TMA. For twin TMAs, it is marked as "ANT 0 or ANT 1".
  - 3.2. Route a second jumper cable from the PCS antenna port to the TMA port marked "ANT PCS" for dual band TMA. For twin TMAs, it is marked as "ANT 0 or ANT 1".
  - 3.3. Route a third jumper cable from the TMA port marked "AWS BTS" for dual-band TMA to the tower feeder for the AWS Node B/BTS. For twin TMAs, it is marked as "BTS 0 or BTS 1".
  - 3.4. Route a fourth jumper cable from the TMA port marked "PCS BTS" for dual band TMA to the tower feeder for the PCS Node B/BTS. For twin TMAs, it is marked as "BTS 0 or BTS 1". Be sure to provide adequate curve or loop to relieve undue strain on connectors at either end.
4. Tighten RF connections to 18 ft-lbs (25 Nm) torque.

5. Weatherproof the cable connections per standard practices if required by local conditions. Provided materials, if any, can be applied according to the instructions on the package.
6. If AISG port **is used** to connect to the RET actuators, make sure that the AISG cable (connecting TMA to the actuator) is hand tightened. Over tightening the cable connection on TMA side or Actuator side can damage the AISG pins. AISG cable has a male and a female 8-in circular connector shown in Figure 9. These AISG connectors have locking screw-rings and are keyed to provide a matching fit with the ports on the actuator and TMA. No weatherproofing is required.
7. If AISG is **not used**, please ensure that the AISG cap provided with the TMA is attached and hand tightened.
8. Apply cable ties or straps (not supplied) to secure the cables to the tower structure.

## MOUNTING TO A WALL

---

The TMA can be mounted to a suitable flat surface.

1. Mount the TMA to the wall using four 5/16" or 8 mm bolts (not supplied) through the holes in the TMA brackets.
2. Connect RF, AISG and ground cables, weatherproof and secure with straps as outlined above.

**NOTICE**

The installation, maintenance, or removal of antenna systems requires qualified, experienced personnel. Andrew installation instructions are written for such installation personnel. Antenna systems should be inspected once a year by qualified personnel to verify proper installation, maintenance, and condition of equipment.

Andrew disclaims any liability or responsibility for the results of improper or unsafe installation practices.

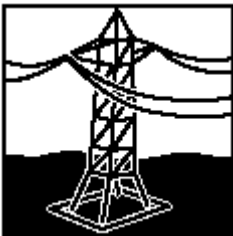

Do not install near power lines. Power lines, telephone lines, and guy wires look the same. Assume any wire or line can electrocute you.



Do not install on a wet or windy day or when lightning or thunder is in the area. Do not use metal ladder.



Wear shoes with rubber soles and heels. Wear protective clothing including a long-sleeved shirt and rubber gloves.