

# E11F02P45

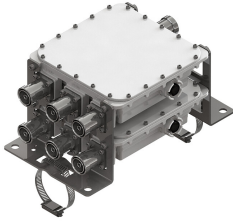

## 2X Triplexer 1710-1880/1920-2170/2300-2600, dc bypass on port 3

- Industry leading PIM performance
- Designed for network Modernization, introduction of LTE1800 on existing site
- Designed for network Modernization, introduction of LTE2600 on existing site
- Twin configuration

### OBSOLETE

This product was discontinued on: June 30, 2022

#### Replaced By:

E12F01P81

2X Triplexer 1710-1880/1920-2170/2300-2690, dc bypass on all ports with 4.3-10 connectors

## Product Classification

**Product Type** Triplexer

## General Specifications

<b>Product Family</b>	CBC182126
<b>Color</b>	Gray
<b>Common Port Label</b>	COM
<b>Modularity</b>	2-Twin
<b>Mounting</b>	Pole   Wall
<b>Mounting Pipe Hardware</b>	Band clamps (2)
<b>RF Connector Interface</b>	7-16 DIN Female
<b>RF Connector Interface Body Style</b>	Medium neck

## Dimensions

<b>Height</b>	182.5 mm   7.185 in
<b>Width</b>	129 mm   5.079 in
<b>Depth</b>	173.5 mm   6.831 in
<b>Mounting Pipe Diameter Range</b>	42.6–122 mm

# E11F02P45

## Outline Drawing

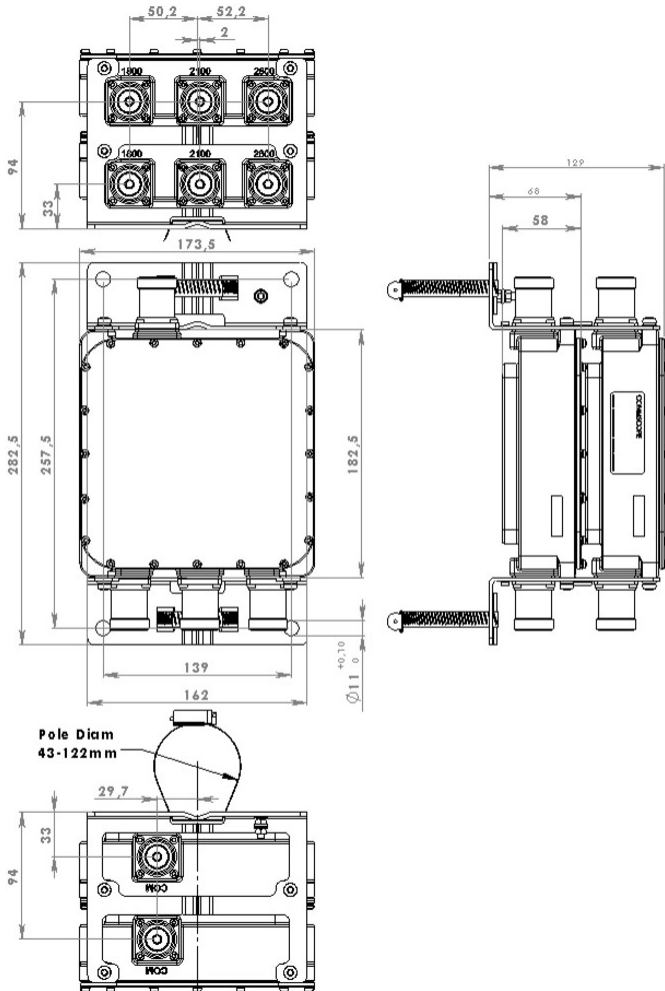

## Electrical Specifications

<b>Impedance</b>	50 ohm
<b>License Band, Band Pass</b>	DCS 1800   IMT 2100   IMT 2600

## Electrical Specifications, dc Power/Alarm

<b>dc/AISG Pass-through, combiner</b>	Branch 3
<b>dc/AISG Pass-through, demultiplexer</b>	Branch 3
<b>Lightning Surge Current</b>	5 kA
<b>Lightning Surge Current Waveform</b>	8/20 waveform

# E11F02P45

---

## Electrical Specifications

<b>Sub-module</b>	<b>1   2</b>	<b>1   2</b>	<b>1   2</b>
<b>Branch</b>	1	2	3
<b>Port Designation</b>	1800	2100	2600
<b>License Band</b>	DCS 1800, Band Pass IMT 2100, Band Pass IMT 2600, Band Pass		

## Electrical Specifications, Band Pass

<b>Frequency Range, MHz</b>	<b>1710–1880</b>	<b>1920–2170</b>	<b>2300–2690</b>
<b>Insertion Loss, typical, dB</b>	0.25	0.25	0.2
<b>Return Loss, minimum, dB</b>	18	18	18
<b>Return Loss, typical, dB</b>	20	20	20
<b>Isolation, minimum, dB</b>	50	50	50
<b>3rd Order PIM, typical, dBc</b>	-160	-160	-160
<b>3rd Order PIM Test Method</b>	Two +43 dBm carriers	Two +43 dBm carriers	Two +43 dBm carriers

# E11F02P45

## Block Diagram

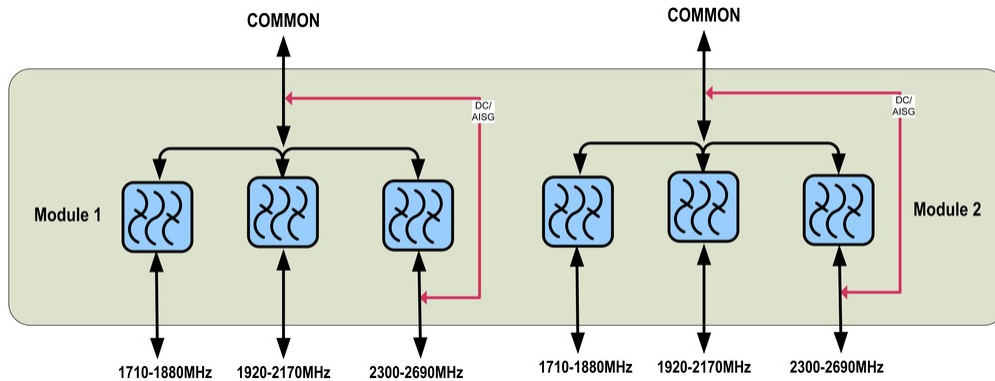

## Environmental Specifications

<b>Operating Temperature</b>	-40 °C to +60 °C (-40 °F to +140 °F)
<b>Relative Humidity</b>	Up to 100%
<b>Corrosion Test Method</b>	IEC 60068-2-11, 30 days
<b>Ingress Protection Test Method</b>	IEC 60529:2001, IP67

## Packaging and Weights

<b>Included</b>	Mounting hardware
<b>Volume</b>	3.9 L
<b>Weight, net</b>	6.2 kg   13.669 lb

## Regulatory Compliance/Certifications

<b>Agency</b>	<b>Classification</b>
ISO 9001:2015	Designed, manufactured and/or distributed under this quality management system

