

# E11F02P25



Triplexer 790-862//880-960//1710-2170 MHz, dc bypass on High band port

## OBSOLETE

This product was discontinued on: July 1, 2022

### Replaced By:

E14F10P05

Single Triplexer 700-800//900//1800-2600 MHz, DC Bypass on high ports, with 4.3-10 connectors

## Product Classification

**Product Type** Triplexer

## General Specifications

**Product Family** CBC8921

**Color** Gray

**Common Port Label** COM

**Modularity** 1-Single

**Mounting** Pole | Wall

**Mounting Pipe Hardware** Band clamps (2)

**RF Connector Interface** 7-16 DIN Female

**RF Connector Interface Body Style** Medium neck

## Dimensions

**Height** 255 mm | 10.039 in

**Width** 285 mm | 11.22 in

**Depth** 67 mm | 2.638 in

**Mounting Pipe Diameter Range** 42.6–122 mm

# E11F02P25

## Outline Drawing

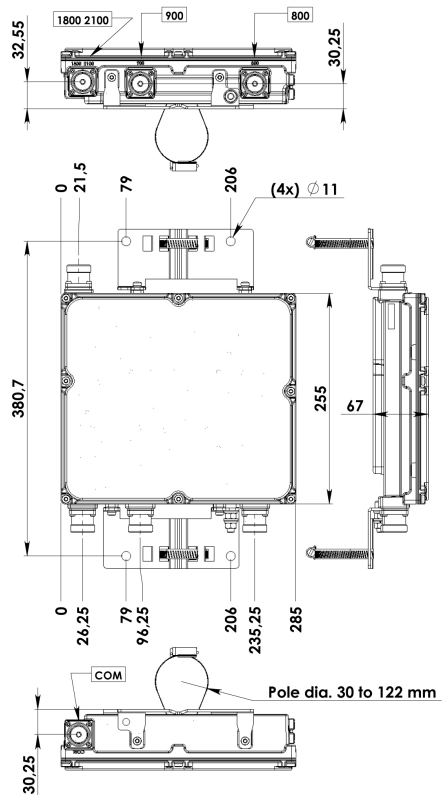

## Electrical Specifications

<b>Impedance</b>	50 ohm
<b>License Band, Band Pass</b>	CEL 900   DCS 1800   EDD 800   IMT 2100

## Electrical Specifications, dc Power/Alarm

<b>dc/AISG Pass-through, combiner</b>	Branch 3
<b>dc/AISG Pass-through, demultiplexer</b>	Branch 3
<b>Lightning Surge Current</b>	5 kA
<b>Lightning Surge Current Waveform</b>	8/20 waveform

# E11F02P25

---

## Electrical Specifications

<b>Sub-module</b>	<b>1</b>	<b>1</b>	<b>1</b>
<b>Branch</b>	1	2	3
<b>Port Designation</b>	800	900	1800-2100
<b>License Band</b>	EDD 800, Band Pass	CEL 900, Band Pass	DCS 1800, Band Pass IMT 2100, Band Pass

## Electrical Specifications, Band Pass

<b>Frequency Range, MHz</b>	<b>790–862</b>	<b>880–960</b>	<b>1710–2170</b>
<b>Insertion Loss, maximum, dB</b>	0.4	0.4	0.4
<b>Return Loss, minimum, dB</b>	21	21	21
<b>Isolation, minimum, dB</b>	50	50	50
<b>3rd Order PIM, maximum, dBc</b>	-160	-160	-160
<b>3rd Order PIM Test Method</b>	Two +43 dBm carriers	Two +43 dBm carriers	Two +43 dBm carriers

# E11F02P25

## Block Diagram

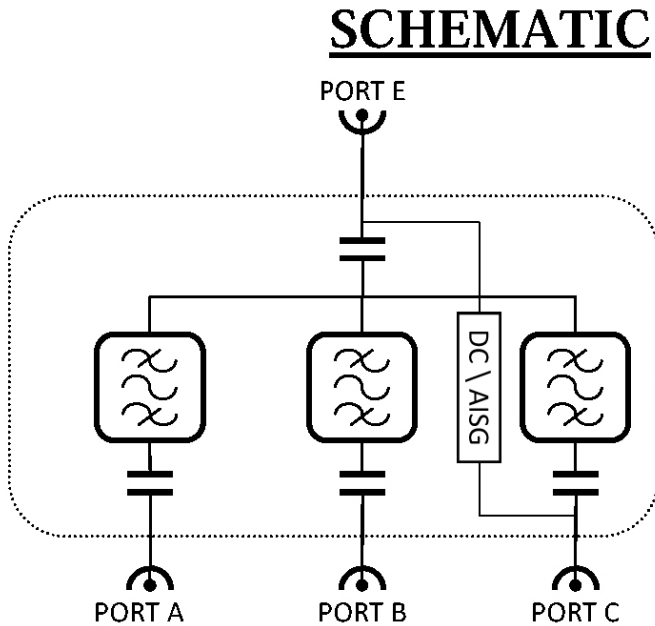

## Environmental Specifications

<b>Operating Temperature</b>	-40 °C to +60 °C (-40 °F to +140 °F)
<b>Relative Humidity</b>	Up to 100%
<b>Corrosion Test Method</b>	IEC 60068-2-11, 30 days
<b>Ingress Protection Test Method</b>	IEC 60529:2001, IP67

## Packaging and Weights

<b>Included</b>	Mounting hardware
<b>Volume</b>	4.9 L
<b>Weight, net</b>	6.5 kg   14.33 lb

## Regulatory Compliance/Certifications

**Agency**

ISO 9001:2015

**Classification**

Designed, manufactured and/or distributed under this quality management system