

4

3

2

1

NOTES:

1.0 GENERAL NOTES

- 1.1 ALL METRIC DIMENSIONS ARE IN BRACKETS
- 1.2 FOR PATENTS, SEE WWW.CS-PATENTS.COM
- 1.3 MARK PART WITH IDENTIFICATION NUMBER

2.0 DESIGN NOTES

3.0 MANUFACTURING/SPECIAL REQUIREMENTS

4.0 TEST

5.0 PACKAGING

REVISIONS				
REV.	ECN	DESCRIPTION	BY	DATE
A	8000039194	INITIAL RELEASE	JLA	02/06/20
B	8000040466	CHANGING SAB01B TO SAB01	JLA	04/23/20

Each kit contains two of the following:

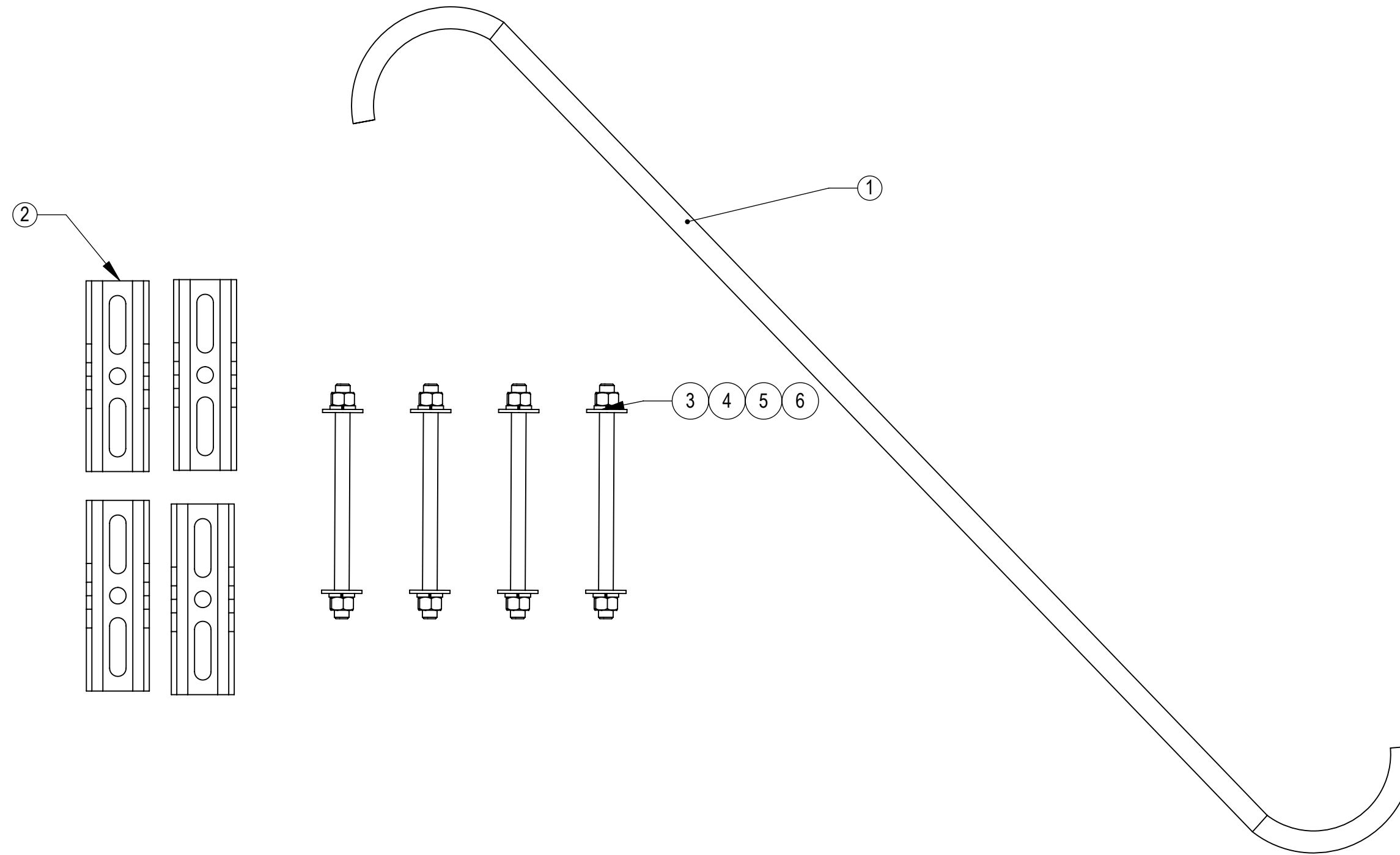

COMMSCOPE, INC. OF NORTH CAROLINA

TOLERANCES		SAP MATERIAL MASTER	
1 PLACE .X ± .25	3 PLACE .XXX ± 0.06	MTC4092-1000	
2 PLACE .XX ± 0.12	ANGLES ± 2°		
FINISH GALV A123		MATERIAL A529, A1011/A1018	

ITEM NO.	PART NUMBER	DESCRIPTION	Kit/QTY.
1	MTC4092-0001	SFG REINFORCEMENT ROD	2
2	SAB01	FORMED CLAMP	8
3	GW-F-04	1/2" GALV FLAT WASHER	16
4	GW-L-04	1/2" GALV LOCK WASHER	16
5	GN-04	1/2" GALV HEX NUT	16
6	MT-379-8	1/2" X 8" GALV THREADED ROD	8

DENSITY		lbs/in ³
MASS	28.77	lbs
VOLUME	101.59	in ³
SURFACE AREA	916.01	in ²
HEIGHT		
LENGTH		
WIDTH		

UNLESS OTHERWISE SPECIFIED DIMENSIONS ARE IN INCHES INTERPRET PER ANSI Y 14.5M-1994	NAME	DATE	TITLE				
	CE JAT132	1/31/2020	SFG Reinforcement Kit				
	RW JAT132	05/04/2020					
	RV						
	AD ES1081	05/05/2020					
RE JAT132	05/06/2020	SCALE	DOCUMENT NO.				
ECN 008000040466		1:8	MTC4092-1000				
SIZE	WORK AREA 24	MODEL			DRAWING		SHEET 1 OF 2
C		VERSION	STATUS	REVISION	VERSION	STATUS	
		01	RE	B	01	RE	B

4

3

2

1

NOTES:

SFG2367L NOT INCLUDED

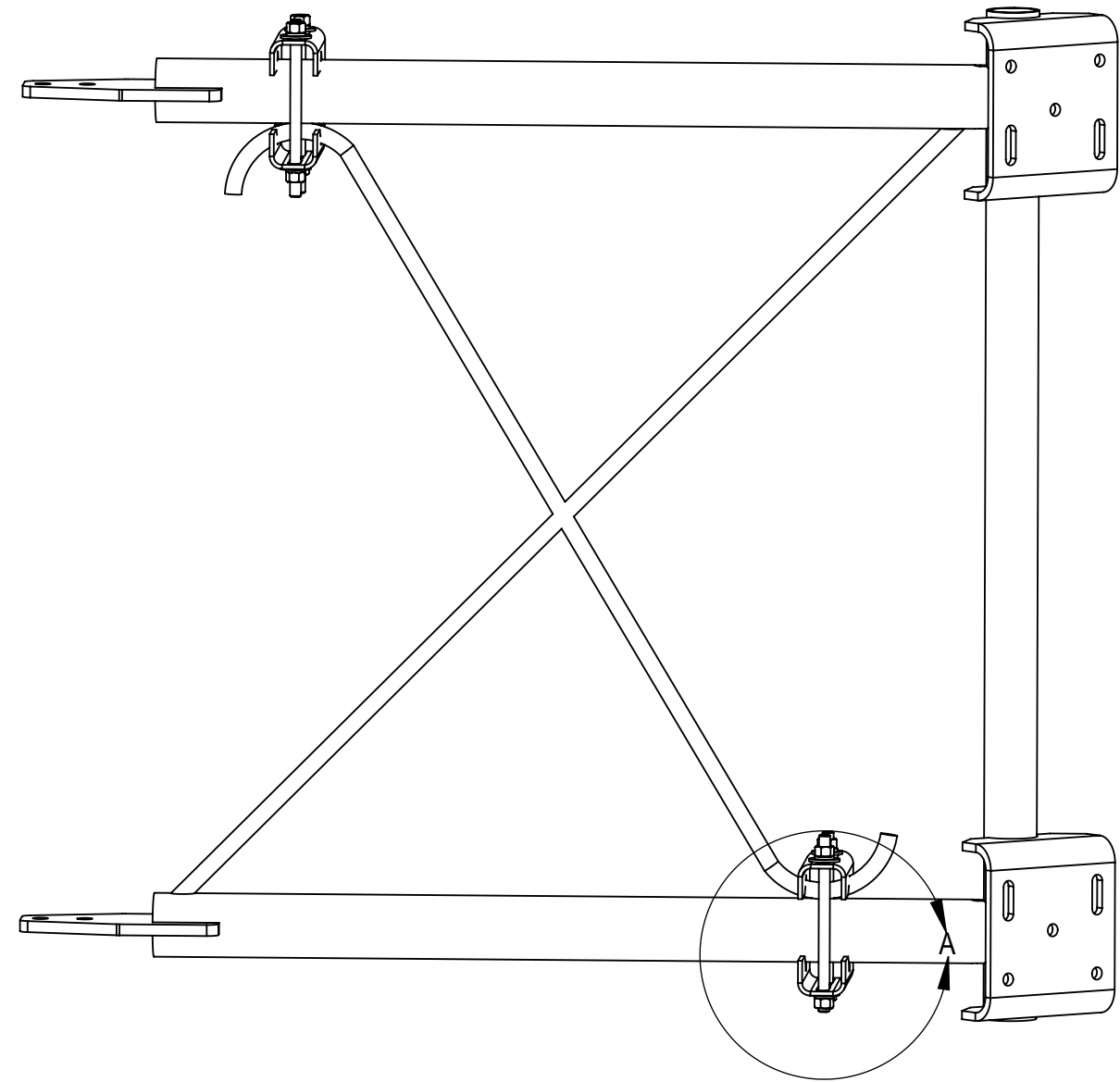

SFG2278 NOT INCLUDED

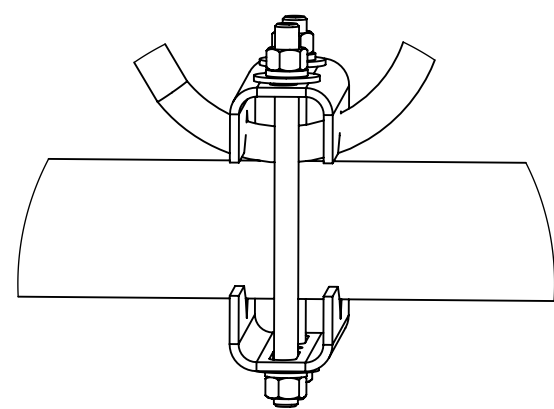
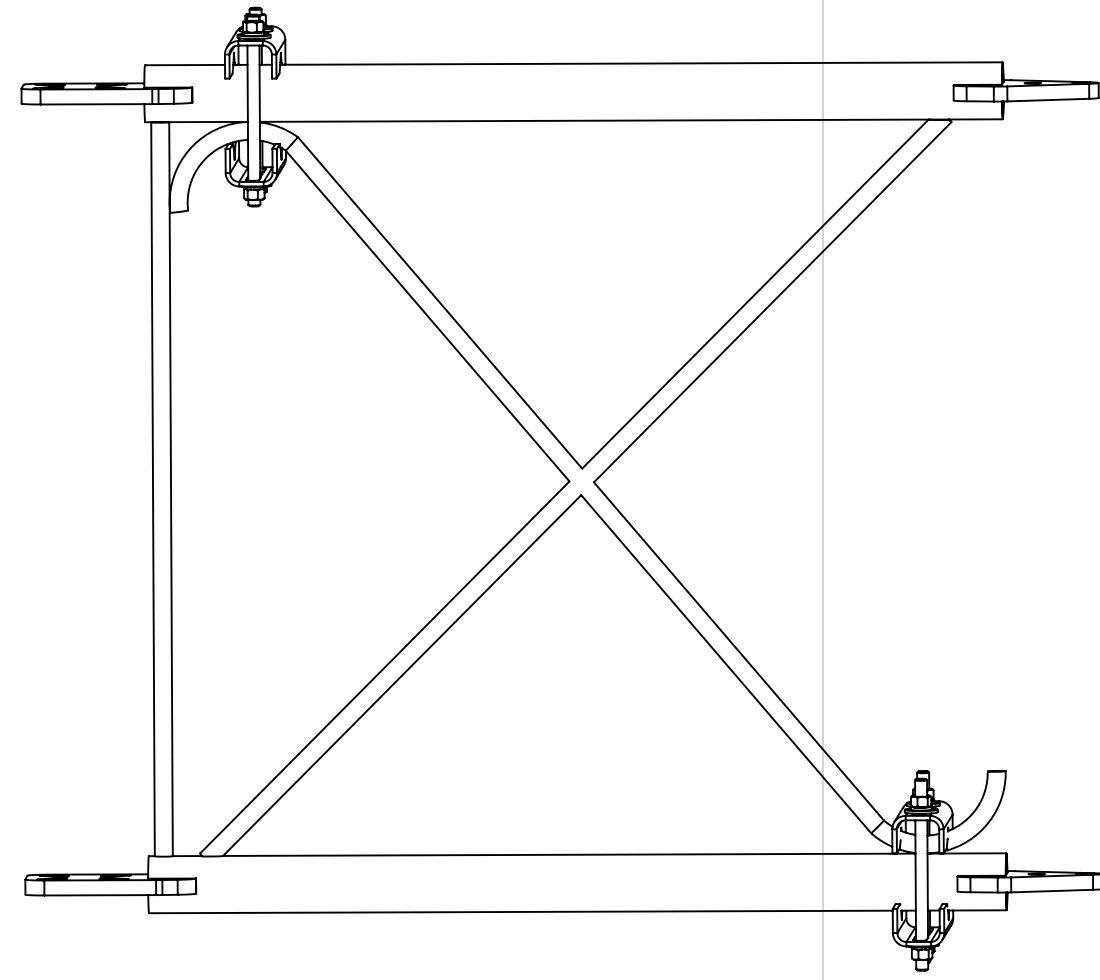

DETAIL A
SCALE 1 : 4

COMMSCOPE, INC. OF NORTH CAROLINA				
TITLE SFG Reinforcement Kit				
SIZE C	SCALE 1:8	DOCUMENT NO. MTC4092-1000		
		DRAWING		SHEET
		VERSION	STATUS	REVISION
		01	RE	B
				2 OF 2

4

3

2

1