

Fiber Distribution Hub

## Indoor 288 FDH 3000 Cabinet

### User Manual

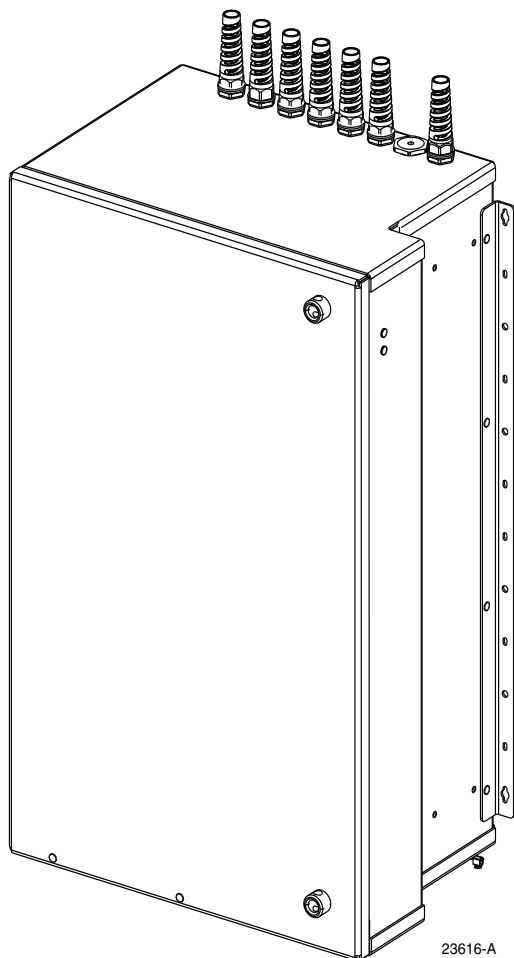

ADCP-96-121  
Rev B, September 2022

## COPYRIGHT

© 2022, CommScope Inc.  
All Rights Reserved

## REVISION HISTORY

ISSUE	DATE	REASON FOR CHANGE
1	10/2007	Original release
2	8/2010	Product design changes and product installation changes
Rev B	September 2022	Rebrand to CommScope

## TRADEMARK INFORMATION

CommScope, CommScope(logo), and NG4access are registered trademarks of CommScope, Inc.

Telcordia is a registered trademark of Telcordia Technologies, Inc.

GORE is a registered trademark of W. L. Gore & Associates, Inc.

## DISCLAIMER OF LIABILITY

Contents herein are current as of the date of publication. CommScope reserves the right to change the contents without prior notice. **In no event shall CommScope Inc. be liable for any damages resulting from loss of data, loss of use, or loss of profits and CommScope Inc. further disclaims any and all liability for indirect, incidental, special, consequential or other similar damages. This disclaimer of liability applies to all products, publications and services during and after the warranty period.**

This publication may be verified at any time by contacting CommScope's Technical Assistance Center at <http://www.commscope.com/SupportCenter>

**COMMSCOPE®**

# TABLE OF CONTENTS

Content	Page
ABOUT THIS MANUAL .....	v
RELATED PUBLICATIONS .....	v
ADMONISHMENTS .....	v
GENERAL SAFETY PRECAUTIONS .....	v
STANDARDS CERTIFICATION .....	vi
LIST OF ACRONYMS AND ABBREVIATIONS .....	vi
<b>1 DESCRIPTION .....</b>	<b>1</b>
<b>1.1 Indoor 288 FDH 3000 Cabinet .....</b>	<b>1</b>
<b>2 BEFORE STARTING THE INSTALLATION .....</b>	<b>5</b>
<b>2.1 Installation Overview .....</b>	<b>5</b>
<b>2.2 Unpacking and Inspection .....</b>	<b>5</b>
<b>2.3 Installation Hardware .....</b>	<b>6</b>
<b>2.4 Cable and Cabinet Grounding .....</b>	<b>6</b>
<b>2.5 Tools and Materials Required for Installation .....</b>	<b>6</b>
<b>3 MOUNTING THE CABINET IN THE EQUIPMENT RACK .....</b>	<b>7</b>
<b>3.1 Rack Installation Recommendations .....</b>	<b>7</b>
<b>3.2 Installing the Cabinet in the Equipment Rack .....</b>	<b>7</b>
<b>3.3 Grounding Wire Connection To Cabinet .....</b>	<b>12</b>
<b>4 MOUNTING THE CABINET ON A WALL .....</b>	<b>13</b>
<b>4.1 Wood-Framed Wall Mounting Procedure .....</b>	<b>13</b>
<b>4.2 Grounding Wire Connection To Cabinet .....</b>	<b>14</b>
<b>5 PRE-INSTALLED FEEDER AND DISTRIBUTION CABLE CONFIGURATION INFORMATION .....</b>	<b>16</b>
<b>5.1 Feeder Cable Configuration .....</b>	<b>16</b>
<b>5.2 Distribution Cable Configuration .....</b>	<b>17</b>
<b>6 FEEDER CABLE INSTALLATION AND SPLICING .....</b>	<b>18</b>
<b>6.1 Feeder Cable Installation .....</b>	<b>18</b>
<b>6.2 Grounding Cables with Metallic Members .....</b>	<b>20</b>
<b>6.3 Splicing the Feeder Cable Fibers to the Splitter Fibers - Ribbon Fiber .....</b>	<b>21</b>
<b>6.4 Splicing the Feeder Cable Fibers to the Splitter Fibers - Stranded Fiber .....</b>	<b>26</b>
<b>7 DISTRIBUTION CABLE INSTALLATION AND SPLICING .....</b>	<b>29</b>
<b>7.1 Distribution Cable Installation .....</b>	<b>29</b>
<b>7.2 Splicing the Distribution Cable Fibers to the Distribution Panel Pigtails - Ribbon Fiber .....</b>	<b>32</b>
<b>7.3 Splicing the Distribution Cable Fibers to the Distribution Panel Pigtails - Stranded Fiber .....</b>	<b>36</b>
<b>8 PLUG AND PLAY SPLITTER MODULE INSTALLATION .....</b>	<b>41</b>
<b>9 DISTRIBUTION PANEL INSTALLATION .....</b>	<b>45</b>
<b>10 ROUTING AND CONNECTING THE SPLITTER OUTPUT FIBERS .....</b>	<b>49</b>
<b>10.1 Storing The Splitter Output Fibers .....</b>	<b>49</b>
<b>10.2 Enabling Service To a Subscriber .....</b>	<b>50</b>
<b>11 PASS-THROUGH ROUTING PROCEDURE .....</b>	<b>51</b>
<b>11.1 Sliding Adapter Pack Pass-Through Routing Procedure .....</b>	<b>51</b>
<b>11.2 Splitter Compartment Pass-Through Routing Procedure .....</b>	<b>53</b>

## TABLE OF CONTENTS

Content	Page
12 FEEDER CABLE FIBER RE-ROUTING PROCEDURE.....	55
13 MAINTENANCE AND REPAIR PROCEDURES .....	58
13.1 Painting.....	58
13.2 Distribution Panel Adapter Replacement .....	58
13.3 Splitter Compartment Adapter Replacement.....	59
13.4 Replacing a Damaged Fiber or Connector .....	60
13.5 Door Gasket Replacement .....	61
13.6 Door Replacement.....	61
14 CUSTOMER INFORMATION AND ASSISTANCE .....	64



## ABOUT THIS MANUAL

This publication describes the CommScope indoor 288 FDH 3000 cabinet. Also included are procedures for mounting the cabinet, installing and splicing distribution and feeder cables, installing additional splitter modules, installing additional distribution panels, storing the splitter output fibers, connecting the splitter output fibers to the distribution fibers, and replacing damaged components.

## RELATED PUBLICATIONS

Listed below are related manuals and their publication numbers. Copies of these publications can be ordered online by contacting the CommScope Technical Assistance Center at the following URL:

<http://www.commscope.com/SupportCenter>

Title	Document Number
Optical Fiber Connector Wet and Dry Cleaning Instructions	<b>90-159</b>
FDH 3000 Cabinet Plug And Play Splitter Installation Instructions	<b>96-087</b>

## ADMONISHMENTS

Important safety admonishments are used throughout this manual to warn of possible hazards to persons or equipment. An admonishment identifies a possible hazard and then explains what may happen if the hazard is not avoided. The admonishments — in the form of Dangers, Warnings, and Cautions — must be followed at all times. These warnings are flagged by use of the triangular alert icon (seen below) and are listed in descending order of severity of injury or damage and likelihood of occurrence.



**Danger:** *Danger is used to indicate the presence of a hazard that **will** cause severe personal injury, death, or substantial property damage if the hazard is not avoided.*



**Warning:** *Warning is used to indicate the presence of a hazard that **can** cause severe personal injury, death, or substantial property damage if the hazard is not avoided.*



**Caution:** *Caution is used to indicate the presence of a hazard that **will** or **can** cause minor personal injury or property damage if the hazard is not avoided.*

## GENERAL SAFETY PRECAUTIONS



**Warning:** *Wet conditions increase the potential for receiving an electrical shock when installing or using electrically-powered equipment. To prevent electrical shock, never install or use electrical equipment in a wet location or during a lightning storm.*



**Danger:** Do not look into the ends of any optical fiber. Exposure to laser radiation may result. Do not assume the laser power is turned-off or that the fiber is disconnected at the other end.



**Danger:** Use adequate lifting equipment when moving or installing Fiber Distribution Hub cabinets. Verify that the maximum lift weight rating of the equipment is sufficient to handle the weight of the cabinet.



**Danger:** Do not stand under a Fiber Distribution Hub cabinet as it is being hoisted into position for mounting. A failure of the lifting equipment or apparatus could result in serious personal injury and cause significant damage to the cabinet.



**Warning:** Before digging, check with all local utilities for the presence of buried cables or pipes. Contact with underground cables or pipes, especially electric power cables and gas service lines, could interrupt local utility service and cause serious personal injury and extensive property damage.

## STANDARDS CERTIFICATION

**Telcordia:** This equipment complies with the applicable sections of GR-3123-CORE.

**UL:** This equipment is UL listed. Refer to file E238460 for complete information.

## LIST OF ACRONYMS AND ABBREVIATIONS

The acronyms and abbreviations used in this manual are detailed in the following list:

<b>AWG</b>	American Wire Gauge
<b>C</b>	Centigrade
<b>F</b>	Fahrenheit
<b>FDH</b>	Fiber Distribution Hub
<b>FTTP</b>	Fiber To The Premises
<b>OSP</b>	Outside Plant
<b>PNP</b>	Plug and Play
<b>RBR</b>	Reduced Bend Radius

## 1 DESCRIPTION

This section provides a description of the CommScope indoor 288 FDH 3000 cabinet plus the cabinet specifications.

### 1.1 Indoor 288 FDH 3000 Cabinet

The indoor 288 FDH 3000 cabinet is a secure fiber optic distribution cabinet that is designed to hold the various optical components required for Fiber To The Premises (FTTP) distribution network applications. The cabinet is designed for **rack-mount** and **wall-mount** applications. The rack-mount cabinet may be mounted in a 23-inch, WECO or EIA equipment rack. A typical cabinet is shown in [Figure 1](#).

The cabinet is available with the following four cable options: 1) Factory-installed distribution and feeder cables. 2) Factory-installed distribution cables only. 3) Factory-installed feeder cables only. 4) No factory-installed cables. If the cabinet is equipped with a factory-installed feeder cable, the cable stub will range in length from 50 to 500 feet depending on the option selected. If the cabinet is equipped with factory-installed distribution cables, the cable stubs will range in length from 50 to 200 feet depending on the option selected.

Both ribbon and stranded type feeder and distribution cables are available. Factory installed cables are dielectric only. Customer installed feeder cables may include metallic elements. A grounding kit is available (accessory) for grounding feeder cables that have metallic elements

The feeder and distribution cables enter/exit the cabinet from the top. A set of clamps secure each cable to the inside of the cabinet. A compression fitting secures each cable to the outside of the cabinet and prevents dirt and moisture from entering the cabinet at the cable entry/exit point. Splice trays are provided when feeder and/or distribution pigtail assemblies are ordered. Either ribbon cable trays or stranded cable trays may be specified.

The interior of the indoor 288 FDH 3000 cabinet consists of the following primary components.

**Distribution Panels:** Provide a point for connecting the splitter output fibers with the terminated distribution cable fibers. Each panel provides mounting spaces for 72 bulkhead adapters. A maximum of four distribution panels may be mounted in the cabinet.

**Storage Panel:** Provides a temporary “parking lot” for unused splitter output fibers. Each splitter module is equipped with either 8-position connector packs (8-packs) or 16-position connector packs (16-packs). The storage capacity of the storage panel is dependent on the cabinet option selected. Up to eighteen 8-packs can be mounted in the 8-pack storage panel and up to six 16-position connector packs can be mounted in the 16-pack storage panel.

**Radius Limiters:** Provide a place for storing excess slack from the splitter output fibers.

**Splitter Compartment:** Provides a place for mounting the splitters. Will support up to eighteen splitters. Unused splitter slots can be used for pass-through fibers. The splitters specified for use with the indoor FDH 3000 cabinet are equipped with reduced bend radius fibers.

**Sliding Adapter Pack (Input panel)** – Provides a place for terminating spare feeder cable fibers. Spare feeder cable fibers may be used for signal pass-through functions.

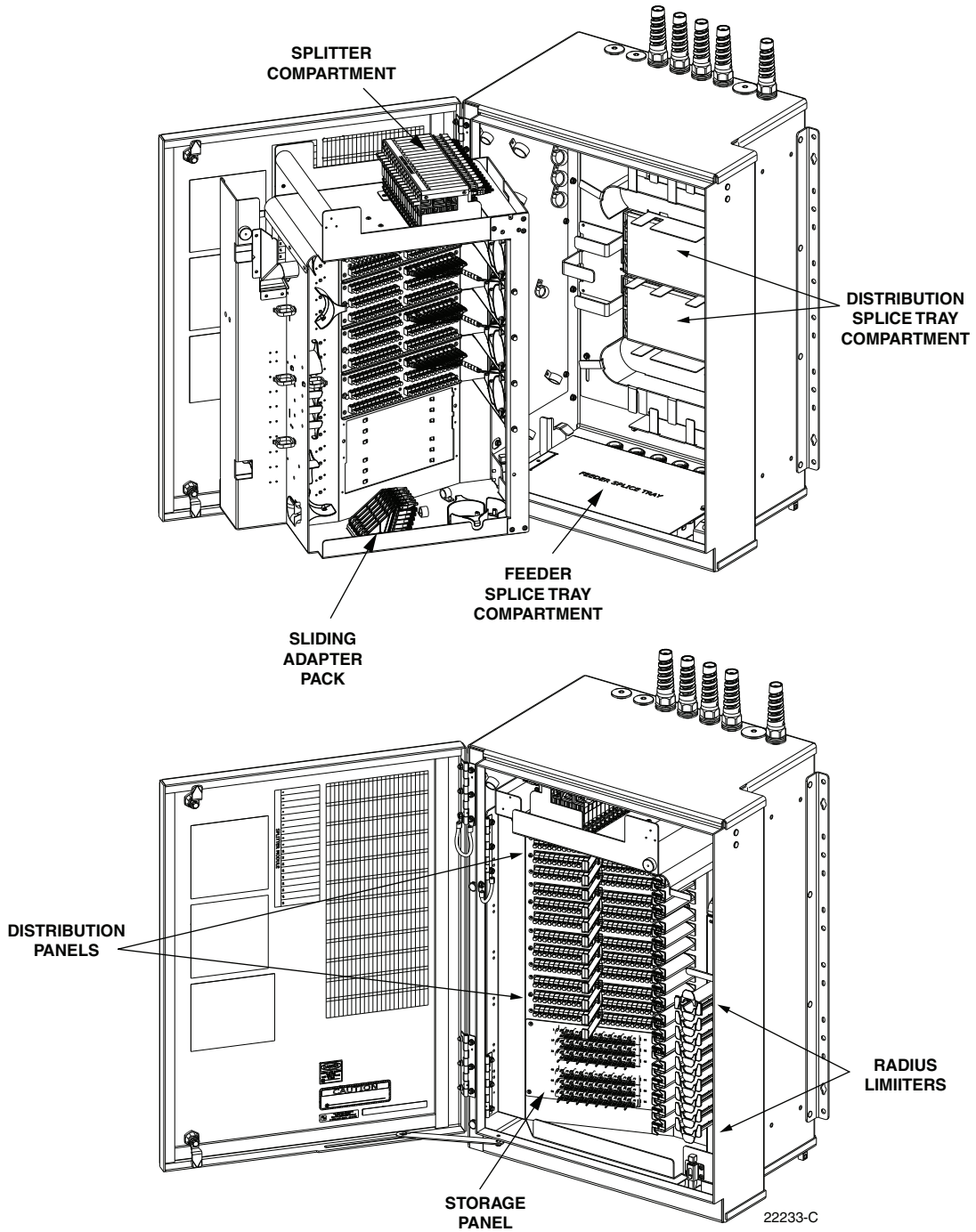

Figure 1. Typical Indoor 288 FDH 3000 Cabinet

**Feeder Cable Splice Tray Compartment:** Provides space for two 5 x 11.75 inch rectangular splice trays when the feeder cable fibers are spliced to the splitter input pigtails. Will accommodate ribbon cable splice trays or stranded cable splice trays. The ribbon cable tray holds up to 72 splices and the stranded cable tray holds up to 36 splices.

**Distribution Cable Splice Tray Compartment:** Provides space for up to eight 5 x 11.75 inch rectangular splice trays when the distribution cable fibers are spliced to the distribution panel pigtails. Will accommodate ribbon cable splice trays or stranded cable splice trays. Each ribbon cable tray provides space for up to 72 splices and each stranded cable tray provides space for up to 36 splices.

The exterior shell of the cabinet is constructed of heavy gauge aluminum and is coated with an almond-colored finish. Each cabinet is equipped with a single front door that provides full front access to the optical components. The cabinet doors are equipped with two tamper-resistant latches, stainless steel hinges, and a door catch that prevents accidental closing. Access to the cabinet requires a 216B key tool (accessory) to release each latch. GORE membrane vents are provided to release any water vapor that may accumulate within the cabinet. The specifications for the 288 FDH 3000 cabinet are provided in [Table 1](#).

**Table 1. Indoor 288 FDH 3000 Cabinet Specifications**

PARAMETER	SPECIFICATION
<b>Cabinet</b>	
Dimensions (H x W x D) See <a href="#">Figure 2</a>	33 x 24.75 x 16.78 x inches (84 x 63 x 43 cm)
Weight (fully loaded)	102 lbs (46.3 kg)
Certification	Telcordia: GR-3123-CORE UL Listed: See file E238460 for complete information.
Distribution panels (maximum)	4
Distribution ports	Up to 288 with four 72-port distribution panels
Distribution port adapters/connectors	UPC/SC or APC/SC,
Splitter compartment splitter capacity	18 splitters
Splitter compartment adapter capacity	36 adapters
Splitter output fiber storage panel capacity (Note: dependent on cabinet options)	144 connectors with 8-pack storage panel 96 connectors with 16-pack storage panel
Sliding adapter pack capacity	36 adapters
Distribution splice trays	Up to 8
Feeder splice trays	Up to 2
Splice tray splice capacities Stranded cable splice trays Ribbon cable splice trays	Up to 36 splices per tray Up to 72 splices per tray
<b>Splitter Modules</b>	
Splitter module output fibers	Reduced bend radius fiber terminated with UPC/SC or APC/SC connectors
Test bandpass	1260–1360 nm, 1480–1500 nm, 1550–1560 nm
Overall bandpass	1260–1625 nm

**Table 1. Indoor 288 FDH 3000 Cabinet Specifications, continued**

PARAMETER	SPECIFICATION
Return loss at test bandpass	≥55 dB
Maximum insertion loss at test bandpass	Note: Specification includes the loss from the input and output connectors
1 x 2	4.1 dB with UPC, 4.3 with APC
1 x 4	7.6 dB with UPC, 7.8 dB with APC
1 x 8	10.7 dB with UPC, 10.9 dB with APC
1 x 16	13.9 dB with UPC, 14.1 dB with APC
1 x 32	17.1 dB with UPC, 17.3 dB with APC
1 x 64	20.8 dB with UPC, 21 dB with APC
2 x 16	14.5 dB with UPC, 14.7 dB with APC
2 x 32	17.8 dB with UPC, 18 with APC

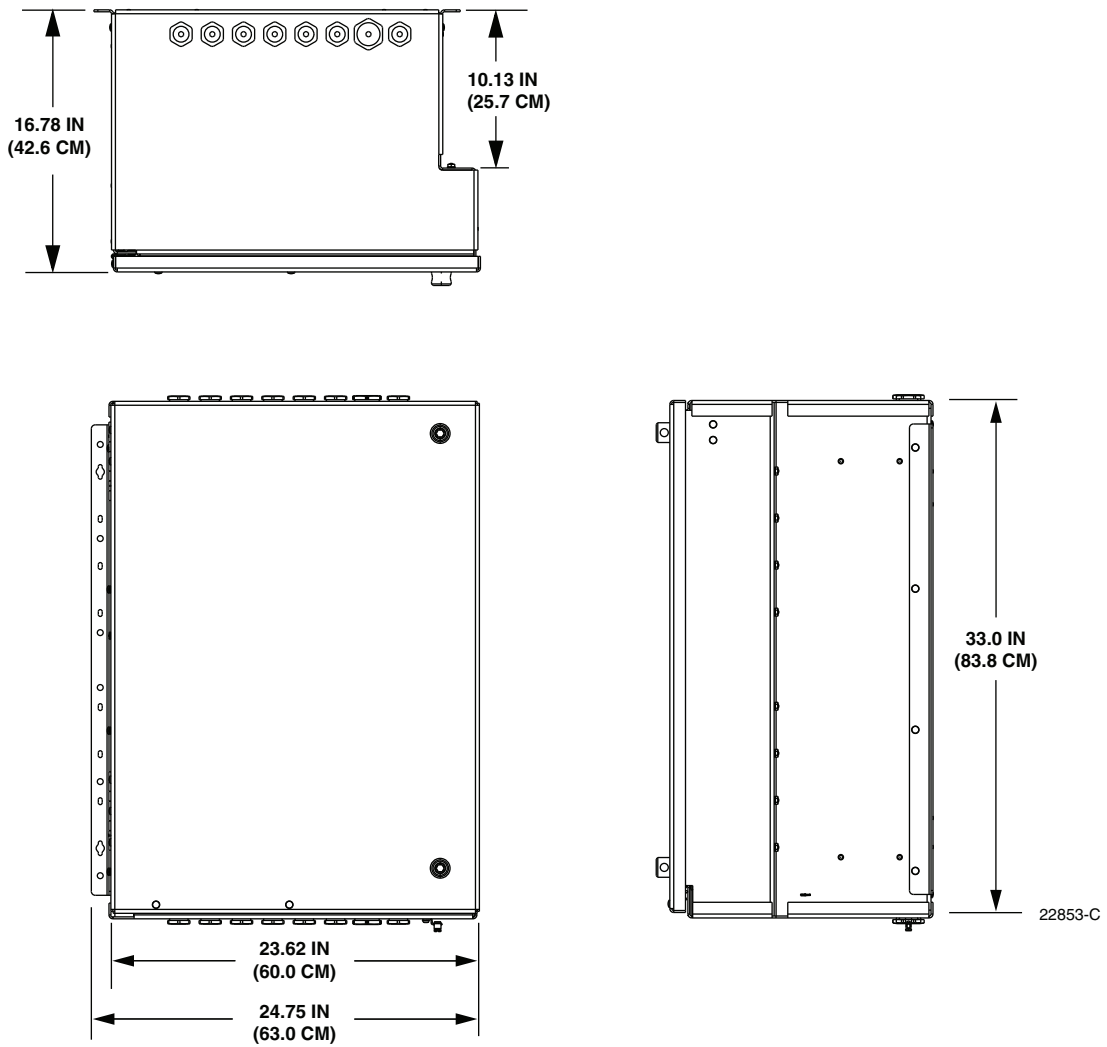

**Figure 2. Indoor 288 Termination Cabinet Dimensions**

## 2 BEFORE STARTING THE INSTALLATION

This section provides general installation considerations, unpacking and inspection procedures, and lists the tools and materials required for indoor 288 FDH 3000 cabinet installation.

### 2.1 Installation Overview

Installation of the indoor 288 cabinet involves the following main tasks:

**Mounting the Cabinet** – The cabinet must be secured to an equipment rack or wall and grounded. If the cabinet is equipped with factory-installed feeder and distribution cables, the cable stubs must be uncoiled and routed to a separate splice enclosure (not provided).

**Splitter Installation** – The cabinet may be ordered with one or two splitters. If additional splitters are required, they must be ordered separately. All splitter modules that are ordered separately must be installed in the splitter compartment.

**Feeder Cable Installation** – If the cabinet is not equipped with a factory-installed feeder cable, then a customer-supplied feeder cable must be routed into the cabinet and spliced to the splitter compartment input pigtails.

**Distribution Cable Installation** – If the cabinet is not equipped with factory-installed distribution cables, then customer-supplied distribution cables must be routed into the cabinet and spliced to the distribution panel pigtails.

**Splitter Output Fiber Connections** – Service is enabled by connecting the splitter output fiber connectors to the subscriber distribution ports. Unused output fibers are temporarily “parked” in the storage panel until they are needed for service.

### 2.2 Unpacking and Inspection

This section provides instructions for opening the shipping boxes, verifying that all parts have been received, and verifying that no shipping damage has occurred.

Use the following procedure to unpack and inspect the cabinet and all accessories:

1. Open the shipping carton(s) and carefully unpack the cabinet and any accessories from the protective packing material.
2. Open the cabinet doors (requires 216B key tool) and check for missing ship-along parts (see installation drawing included with cabinet) or broken parts. If there are damages, contact CommScope (see [Section 14](#)) for an RMA (Return Material Authorization) and to reorder if replacement is required.

## 2.3 Installation Hardware

Various parts for mounting the indoor 288 cabinet are shipped separately with the cabinet. Verify that the parts specified in [Table 2](#) are received.

**Table 2. Cabinet Installation Hardware**

ITEM	QUANTITY
12-24 x 3/8-inch screw	8
#12 star washer	8
#12 flat washer	8
#12 foam washer	20
Mounting bracket (installed)	2

## 2.4 Cable and Cabinet Grounding

The indoor 288 cabinet is equipped with a grounding lug for attaching a grounding wire to the cabinet. A copper block is available separately (accessory) for grounding feeder cables that may have metallic elements. The cabinet and any feeder cables with metallic elements must be connected to an earth ground source. Detailed information on grounding the cabinet is provided in the section that covers cabinet mounting.

## 2.5 Tools and Materials Required for Installation

The following tools and additional materials are required for cabinet installation:

- 216B key tool (accessory - required to open cabinet door)
- Screwdriver (flat blade - medium)
- Torque wrench (with 7/16-inch socket and standard screwdriver socket)
- Hammer
- Pliers
- Wire cutter
- Utility knife
- Tape measure
- Pen or marker
- Splicing equipment
- One large tweezers or two small flat-bladed screwdrivers
- Grounding system, copper wire, and grounding clamp (per local requirements)



### 3 MOUNTING THE CABINET IN THE EQUIPMENT RACK

The indoor 288 FDH 3000 cabinet may be mounted in either a WECO or EIA, 23-inch equipment rack. Sixteen 3/8-inch long 12-24 screws and sixteen #12 star washers are provided for securing the cabinet to the equipment rack.

#### 3.1 Rack Installation Recommendations

The indoor 288 cabinet should be mounted in an equipment rack that is properly secured and grounded in accordance with local requirements. When loading the cabinet in the rack, make sure the mechanical loading of the rack is even to avoid a hazardous condition such as a severely unbalanced rack. The rack should safely support the combined weight of all the equipment it holds. Provide a minimum clearance of 24 inches (61 cm) in front of the cabinet to permit the cabinet door to be fully opened.

The cabinet occupies 33 inches (83.8 cm) of rack space. Additional rack space must be provided either above or below the cabinet for routing the distribution and feeder cables. All fiber optic cables enter/exit the cabinet from either the top or the bottom depending on the option ordered. The installer must provide any cable management devices or systems that may be required to route and secure the fiber optical cables.

Use appropriate lifting equipment when placing the cabinet in position for mounting. It is recommended that at least **two** persons be allocated for positioning and mounting the cabinet.

#### 3.2 Installing the Cabinet in the Equipment Rack

Use the following procedure to install the indoor 288 cabinet in a 23-inch equipment rack:

1. Open the cabinet door and the swing frame as needed during this procedure to provide access to the interior of the cabinet.
2. Remove the nuts, flat washers, foam washers, and carriage bolts (four of each) that secure the **left** mounting bracket to the **left-rear** side of the cabinet as shown in [Figure 3](#).  
▶ **Note:** The cabinet is shipped with the mounting brackets installed in the wall-mount position. This requires that the mounting brackets be moved to the rack-mount position.
3. Remove the **left** mounting bracket from the cabinet and place aside for reuse.
4. Reinstall the carriage bolts, foam washers (use new washers), flat washers, and nuts in the same holes from which they were removed when completing step 2. Tighten nuts securely.  
▶ **Note:** Replace all used foam washers with new foam washers when reinstalling fasteners.
5. Remove the nuts, flat washers, foam washers, and carriage bolts (four of each) from the four holes located on the **left-front** side of the cabinet as shown in [Figure 4](#).
6. Using the carriage bolts, foam washers, flat washers, and nuts removed in step 5, install the left mounting bracket on the **left-front** side of the cabinet (see [Figure 4](#)). Tighten nuts securely.

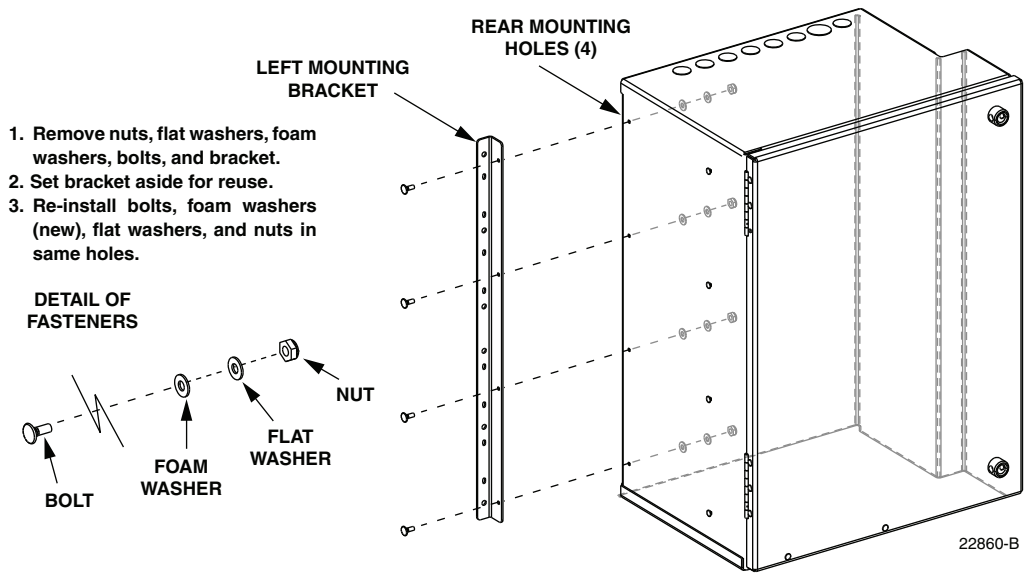

Figure 3. Remove Left Mounting Bracket From Left-Rear Mounting Position

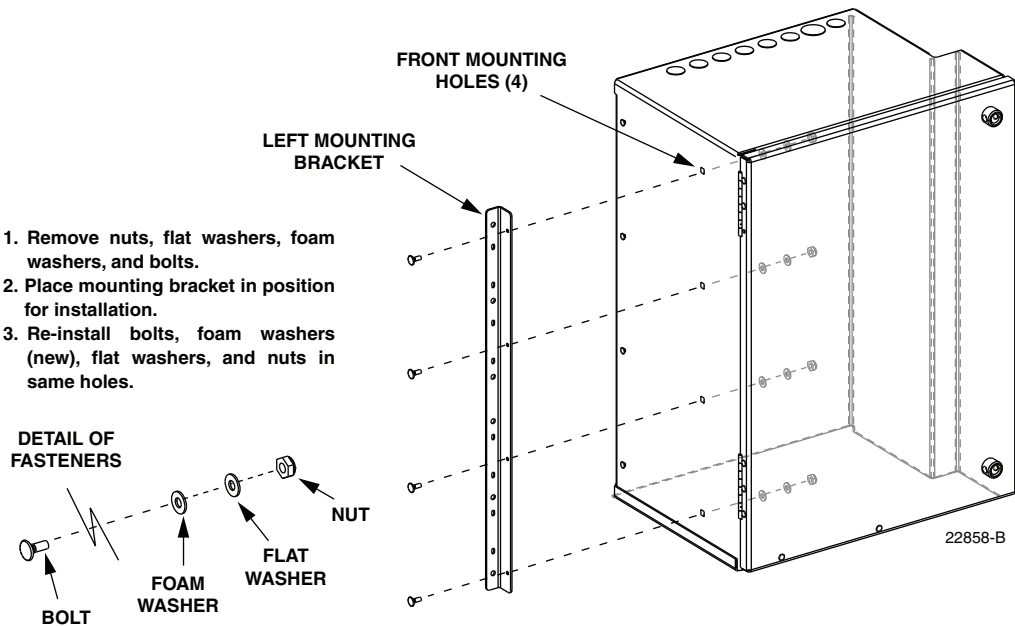
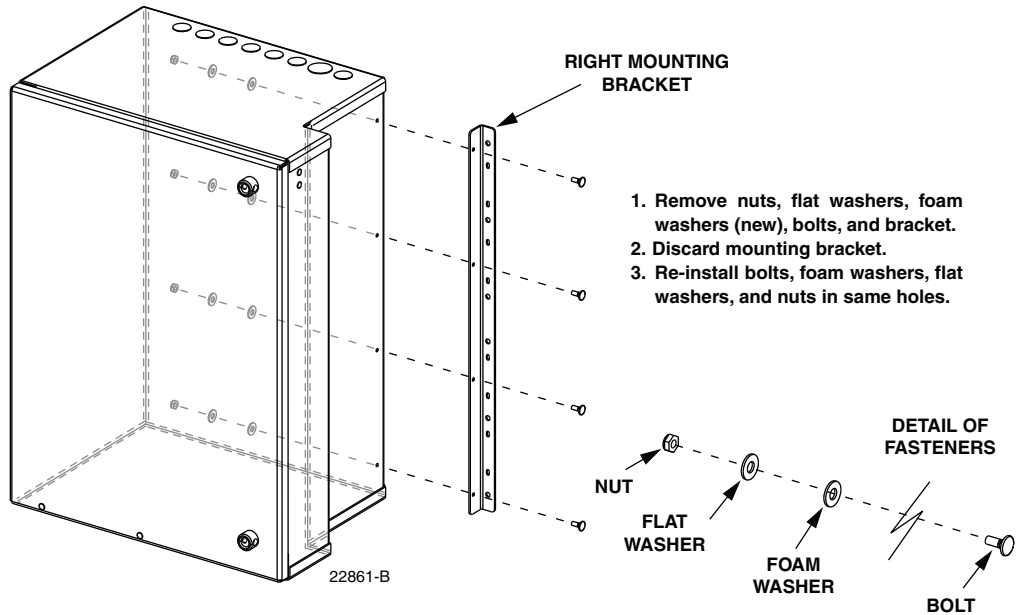

Figure 4. Install Left Mounting Bracket in Left-Front Mounting Position

7. Remove the nuts, flat washers, foam washers, and carriage bolts (four of each) that secure the **right** mounting bracket to the **right-rear** side of the cabinet as shown in [Figure 5](#).
8. Remove the **right** mounting bracket from the cabinet and discard. The right mounting bracket is not used with rack-mount applications.



**Figure 5. Remove Right Mounting Bracket From Rear Mounting Position**

9. Reinstall the carriage bolts, foam washers (use new washers), flat washers, and nuts in the same holes from which they were removed when completing step 7. Tighten nuts securely.
- **Note:** Replace all used foam washers with new foam washers when reinstalling fasteners.
10. Remove the 12-24 screws, star washers, flat washers, foam washers, and 12-24 nuts (8 of each) from the **right** side rack-mounting holes shown in [Figure 6](#).

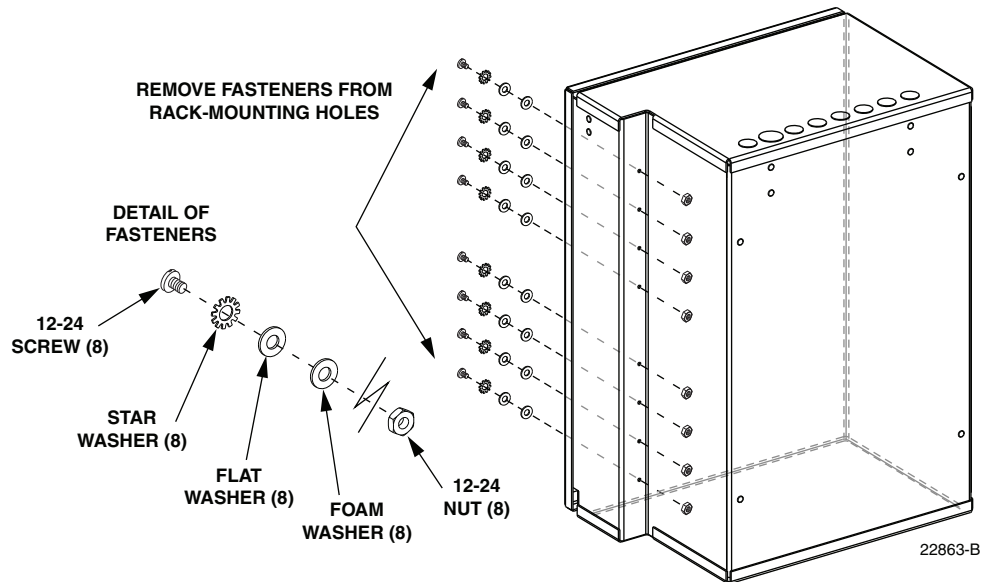

**Figure 6. Remove Fasteners from Right Rack-Mounting Holes**

11. Discard the nuts and foam washers removed in step 10 but save the 12-24 screws, star washers, and flat washers for reuse.
12. Locate the 12-24 rack screws and #12 star washers (8 of each) that are provided separately with the cabinet.
13. Place the cabinet in the specified mounting space within the equipment rack as shown in [Figure 7](#).

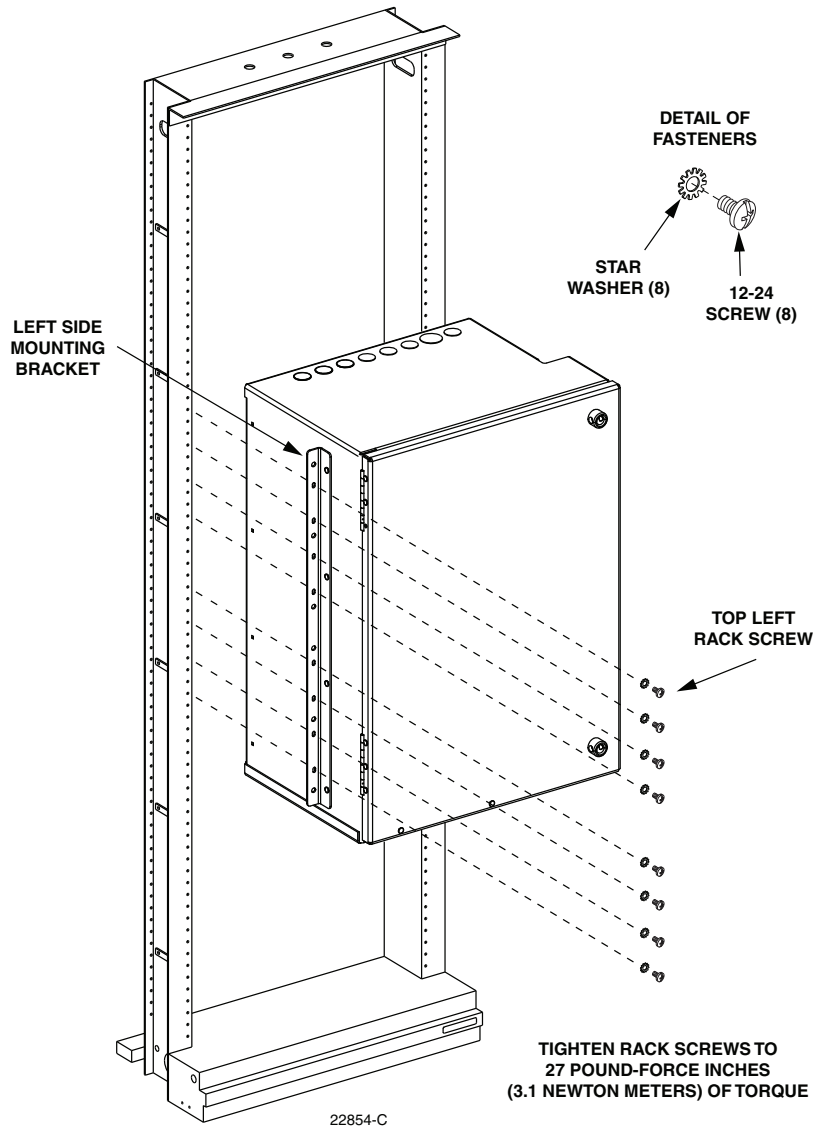

**Figure 7. Placement of Cabinet in Equipment Rack**

14. Install a single 12-24 rack screw (with star washer) in the top hole of the cabinet's **left** side mounting bracket (see [Figure 7](#)).

► **Note:** When installing the rack screws, tighten each screw to 27 pound-force inches (3.1 Newton-meters) of torque.

15. Open the cabinet door and install a single 12-24 rack screw (with star washer, flat washer, and **foam washer**) in the top hole on the **right** side of the cabinet as shown in [Figure 8](#).

► **Note:** Keep the cabinet swing frame closed when installing the initial rack screw(s) on the right side of the cabinet.

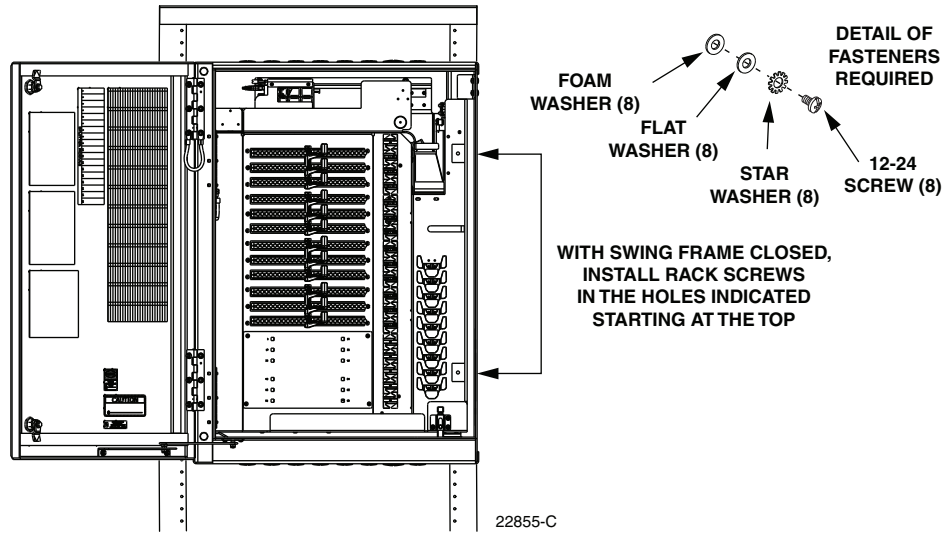

**Figure 8. Right Side Mounting Holes Accessible with Swing Frame Closed**

16. With the cabinet swing frame in the closed position, complete the installation of the left and right side rack screws.
17. Open the cabinet swing frame and install the remaining six right side rack screws as shown in [Figure 9](#).
18. Close the swing frame and relatch the cabinet door when finished.

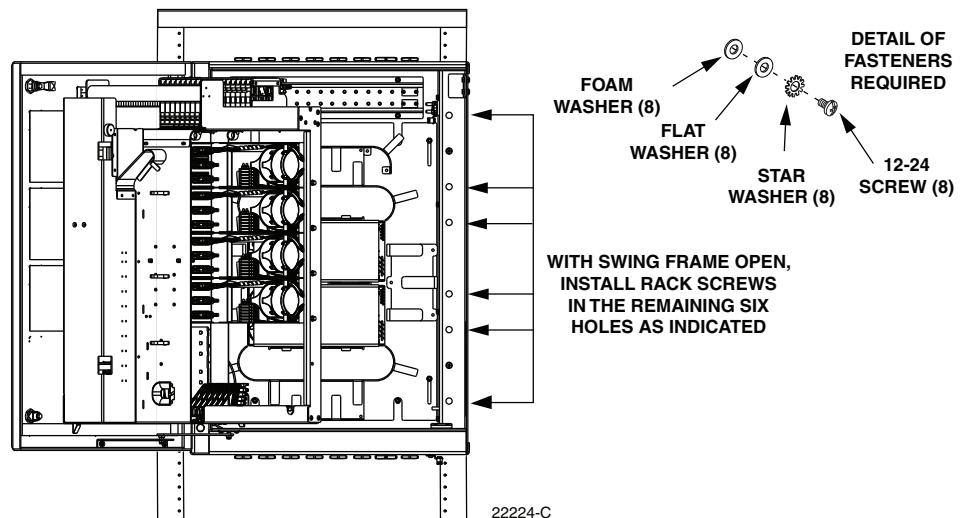
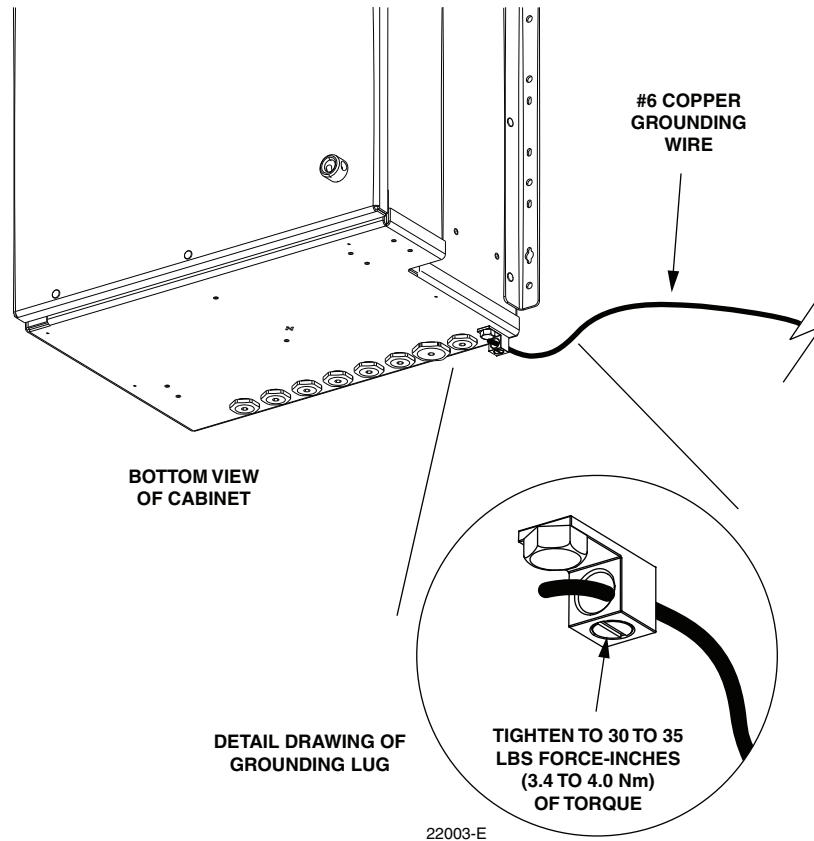

**Figure 9. Right Side Mounting Holes Accessible with Swing Frame Open**

### 3.3 Grounding Wire Connection To Cabinet

A grounding lug is provided with the cabinet for connecting a #6 copper grounding wire to the exterior of the indoor 288 cabinet. Use the following procedure to install the grounding wire:

1. Locate the cabinet grounding lug which is mounted on the underside of the cabinet as shown in [Figure 10](#).



**Figure 10. Grounding Wire Connection To Cabinet**

2. Obtain a length of #6 AWG copper wire for use as a grounding wire.
3. Insert one end of the grounding wire into the cabinet grounding lug. Tighten the grounding lug set screw to 30 to 35 lbs force-inches (3.4 to 4.0 Nm) of torque.
4. Route the free end of the grounding wire to an approved earth ground source.
5. Cut the grounding wire to length and connect it to the earth ground source as specified by local code or practice.

## 4 MOUNTING THE CABINET ON A WALL

The FDH 3000 indoor 288 cabinet may be mounted from most flat vertical surfaces. Two mounting brackets are provided with the cabinet for use in wall-mount installations. Appropriate fasteners for securing the mounting brackets to the mounting surface and an appropriate backer board must be provided by the installer. The type of fasteners required are dependent on the materials and the construction of the mounting surface.

Use appropriate lifting equipment when placing the cabinet in position for mounting. It is recommended that at least **two** persons be allocated for positioning and mounting the cabinet.

### 4.1 Wood-Framed Wall Mounting Procedure

When mounting the cabinet on a wood-framed wall, it is recommended that pressure-treated plywood with a minimum thickness of 0.75-inch (19.0 cm) be used as a backer board. The backer **must** be firmly secured to the interior framing of the wall to avoid a hazardous condition. Use the following procedure to install the cabinet on a wood-framed wall:

1. Mount the plywood backer (not provided) on the wall and firmly secure it to the wall's interior studs.
2. Obtain the following fasteners for securing the cabinet to the plywood backer.
  - 1/4 x 1-1/2-inch lag screws –12
  - 1/4-inch flat washers – 12 for mounting plus additional washers to use as spacers
3. Using [Figure 11](#) as a guide, mark the location of the cabinet mounting holes on the plywood backer.

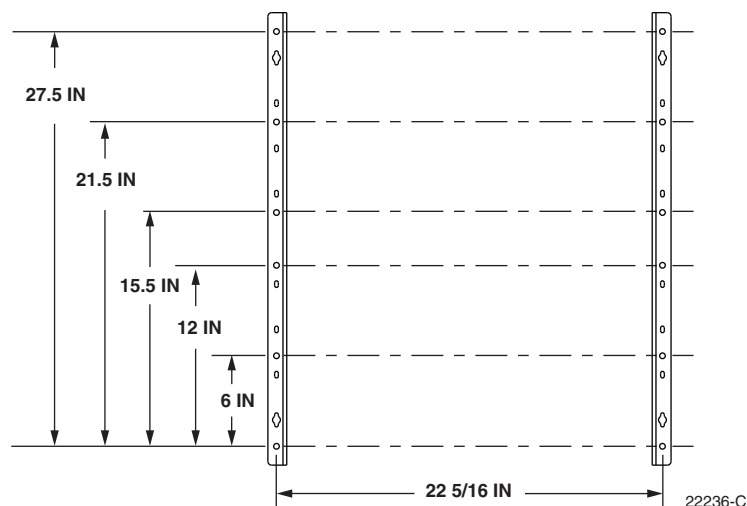

**Figure 11. Hole Locations for Wall-Mount Installation**

4. Drill a 5/32-inch hole in the backer board at each of the locations marked in step 4.

- Secure the cabinet to the plywood backer as shown in [Figure 12](#) using the twelve 1/4 x 1-1/2-inch lag screws and 1/4-inch flat washers. Tighten lag screws securely.

► **Note:** If mounting surface is not flat, level mounting surface by placing spacers (use 1/4-inch flat washers) between the mounting brackets and mounting surface. This will prevent the cabinet from being distorted when the mounting screws are tightened.

- Close swing frame and relatch cabinet door when finished.

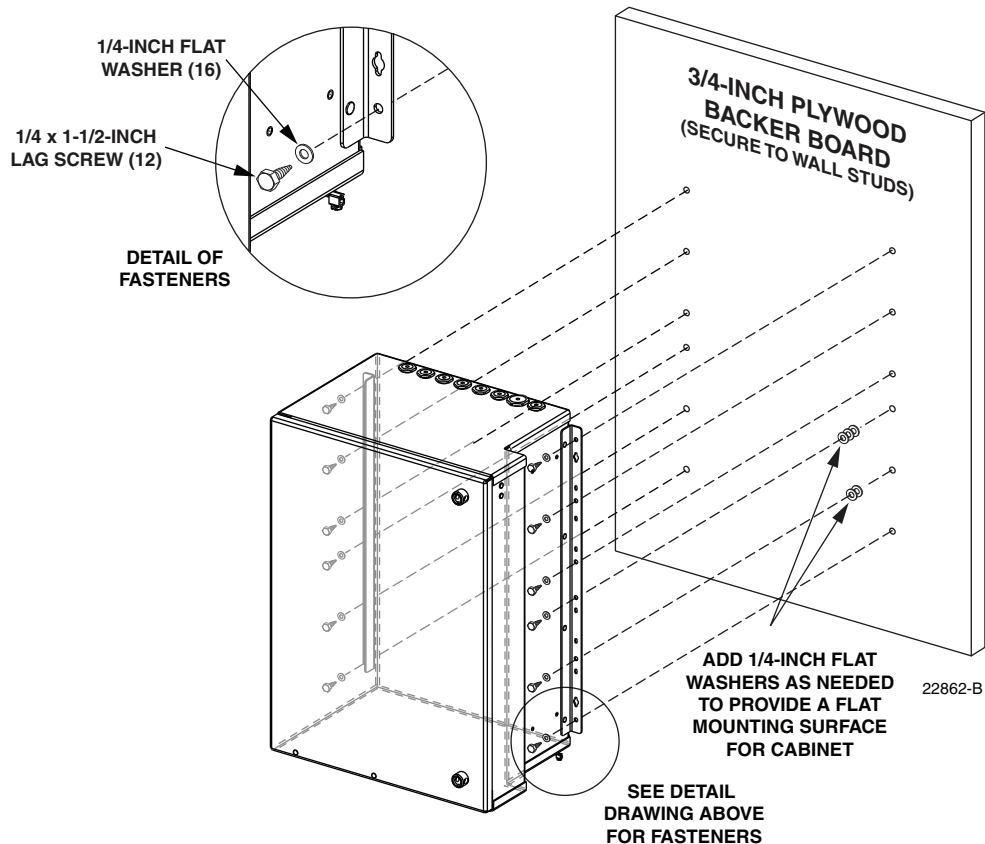

Figure 12. Secure Cabinet to Plywood Backer

## 4.2 Grounding Wire Connection To Cabinet

A grounding lug is provided with the cabinet for connecting a #6 copper grounding wire to the exterior of the indoor 288 cabinet. Use the following procedure to install the grounding wire:

- Locate the cabinet grounding lug which is mounted on the underside of the cabinet as shown in [Figure 13](#).



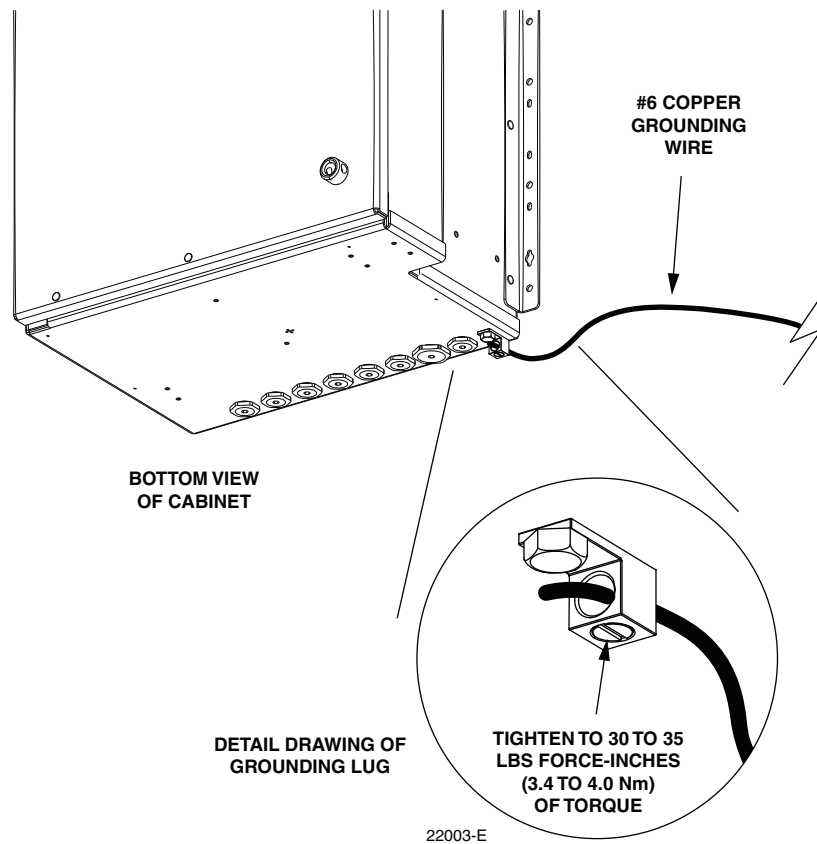

**Figure 13. Grounding Wire Connection To Cabinet**

2. Obtain a length of #6 AWG copper wire for use as a grounding wire.
3. Insert one end of the grounding wire into the cabinet grounding lug. Tighten the grounding lug set screw to 30 to 35 lbs-force inches (3.4 to 4.0 Nm) of torque.
4. Route the free end of the grounding wire to an approved earth ground source.
5. Cut the grounding wire to length and connect it to the earth ground source as specified by local code or practice.

## 5 PRE-INSTALLED FEEDER AND DISTRIBUTION CABLE CONFIGURATION INFORMATION

The 288 FDH 3000 cabinet is available with pre-installed feeder and distribution cables. The cable stub ends must be spliced to the network feeder and distribution cables at a separate splice enclosure (not provided). The feeder and distribution stub cables are available in various lengths depending on the option ordered. The following sections describe how the cables are configured.

### 5.1 Feeder Cable Configuration

The feeder cable may have a fiber count of 12, 24, or 48 fibers depending on the option ordered. Within the indoor 288 cabinet, the feeder cable is secured with a pair of clamps. Beyond the clamps, the outer sheath of the cable is removed to expose the optical fiber subunits. The cable subunits are routed to the splitter compartment. Extra fibers are routed to the sliding adapter pack. The subunits are numbered and the individual fibers are color-coded for identification. Always perform a light test before splicing to verify the port location for each fiber. A drawing of a typical feeder cable routing is shown in [Figure 14](#).

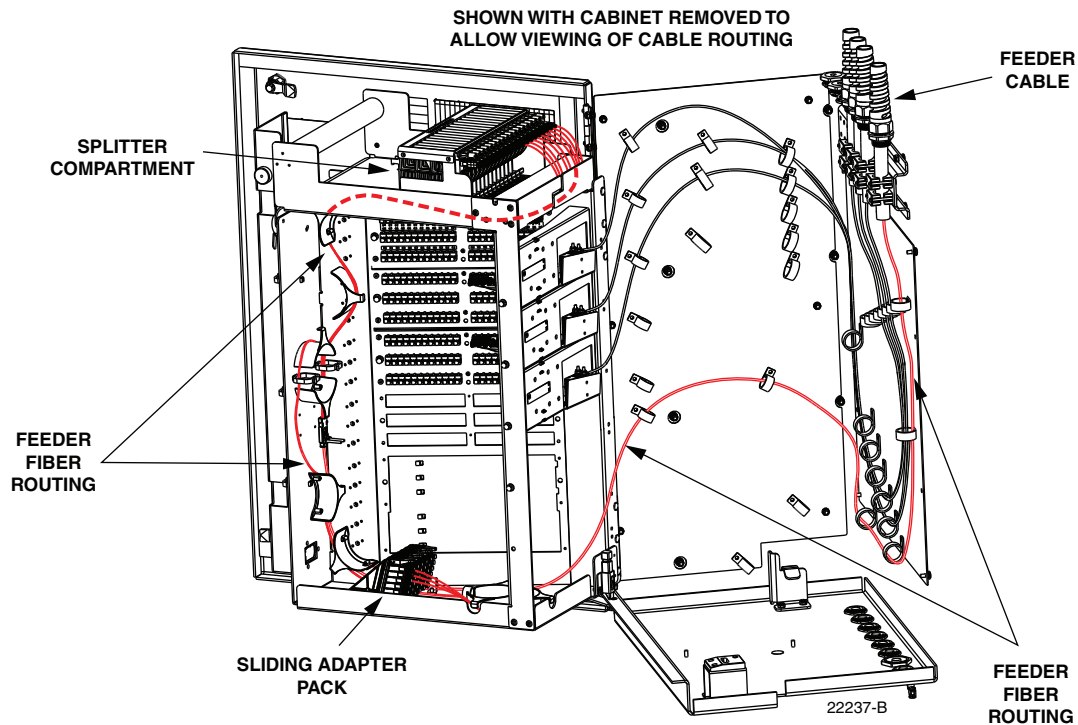

Figure 14. Feeder Cable Typical Configuration - Top Entry

## 5.2 Distribution Cable Configuration

Each distribution cable has a fiber count that is a multiple of 72. From 1 to 4 distribution cables may be present depending on the number of distribution panels ordered and the cable fiber count. Within the cabinet, each distribution cable is secured with a clamp. Beyond the clamp, the outer sheath of the cable is removed to expose the optical fiber subunits. Each subunit is fanned out into 12 individual fibers, each of which is terminated with a connector.

The fiber subunits are routed to the back of the distribution panels. Each fiber connector is connected to a specified bulkhead adapter at the rear of the panel. Depending on the option ordered, the distribution panels may be equipped with either UPC/SC or APC/SC adapters. A drawing of a typical distribution cable configuration is shown in [Figure 15](#). Stranded type distribution cables with 72 or 144 fibers are available. Ribbon type distribution cables with 72, 144, 216, or 288 fibers are available.

Designation labels are provided on the cabinet doors for recording subscriber information for each distribution panel port. The labels indicate the fiber number and cable number associated with each fiber port. The subunits are numbered and the individual fibers are color-coded for identification. Always perform a light test before splicing to determine the port location for each fiber.

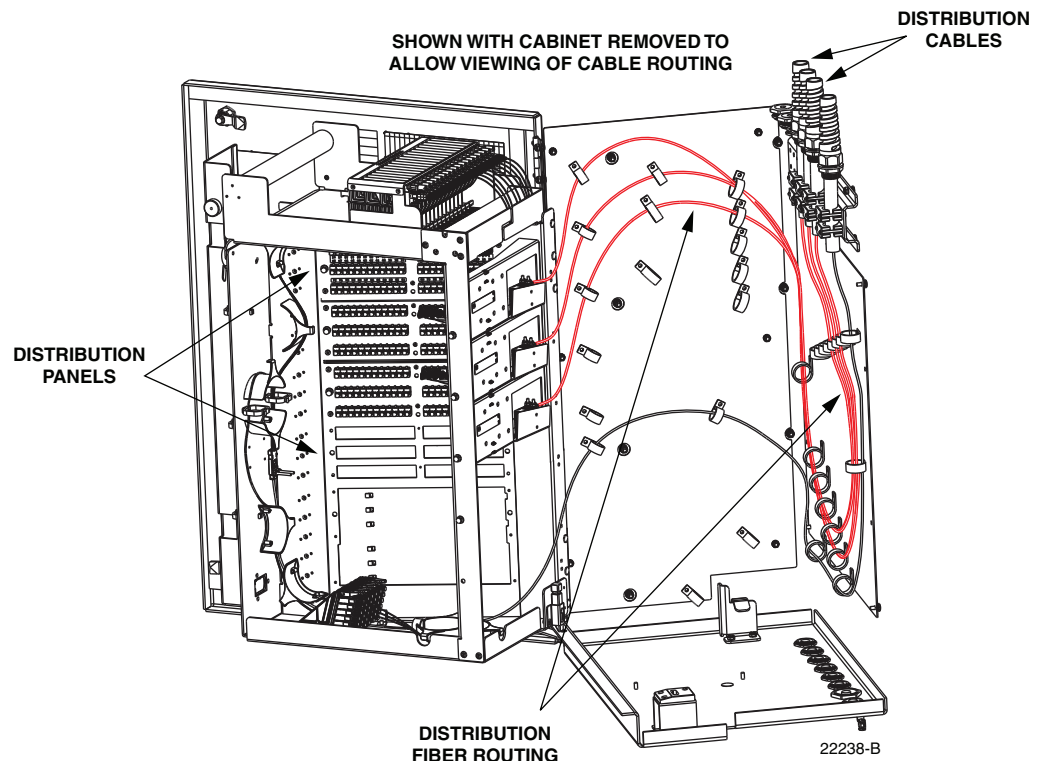

**Figure 15. Distribution Cable Typical Configuration - Top Entry Cabinet**

## 6 FEEDER CABLE INSTALLATION AND SPLICING

The indoor 288 cabinet may be ordered with or without a factory-installed feeder cable. This section describes how to install the OSP feeder cable in cabinets that are not equipped with a pre-installed feeder cable. Also covered are procedures for splicing the feeder cable fibers to the splitter input pigtails. The feeder cable enters/exits the cabinet from the top.

### 6.1 Feeder Cable Installation

A compression fitting is used to secure the feeder cable at the entry/exit point to the cabinet. Within the cabinet, a cable clamp is used to secure the cable to a bracket. Beyond the clamp, the outer sheath of the cable is removed to expose the optical fibers. The feeder cable is typically a 12-, 24-, or 48-fiber cable with stranded or ribbon fiber construction. Breakout kits should be installed (subject to local practice) to protect the exposed optical fibers. Grounding kits should be installed on cables with metallic elements. From the clamping point, the optical fibers are routed to splice trays for splicing to the splitter input pigtails.

Use the following procedure to install the feeder cable:

1. Locate the cable entry/exit hole (on top of the cabinet) that is specified for feeder cable installation as shown in [Figure 16](#).

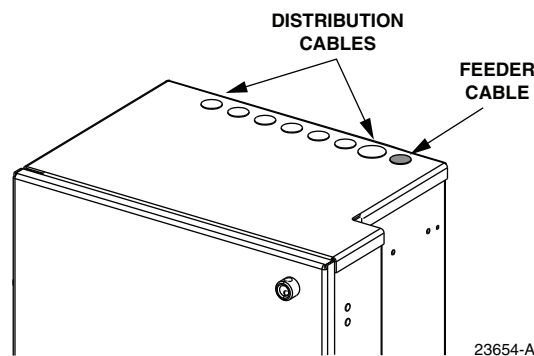

**Figure 16. Cable Entry/Exit Holes**

2. Open the cabinet door and swing frame to provide access to the interior of the cabinet.
  3. Remove the plastic cap and retaining nut from the feeder cable entry/exit hole as shown in [Figure 17](#). Save the retaining nut for reuse.
  4. Locate the spiral compression fitting that is shipped with the cabinet and loosely assemble the compression fitting components (see [Figure 17](#)).
- **Note:** The spiral compression fitting provided with the cabinet can be used with feeder cables that are 0.35 to 0.63 inches in diameter. For cables that are 0.64 to 0.71 inches in diameter, order kit FD3-ACCMSPCLMP.
5. Slide the spiral compression fitting and O-ring over the end of the feeder cable. Loosen the spiral nut if the compression fitting does not slide freely over the cable.
  6. Insert the end of the feeder cable into the cable entry/exit hole and pull through about **13 feet** (4 meters) of cable slack.

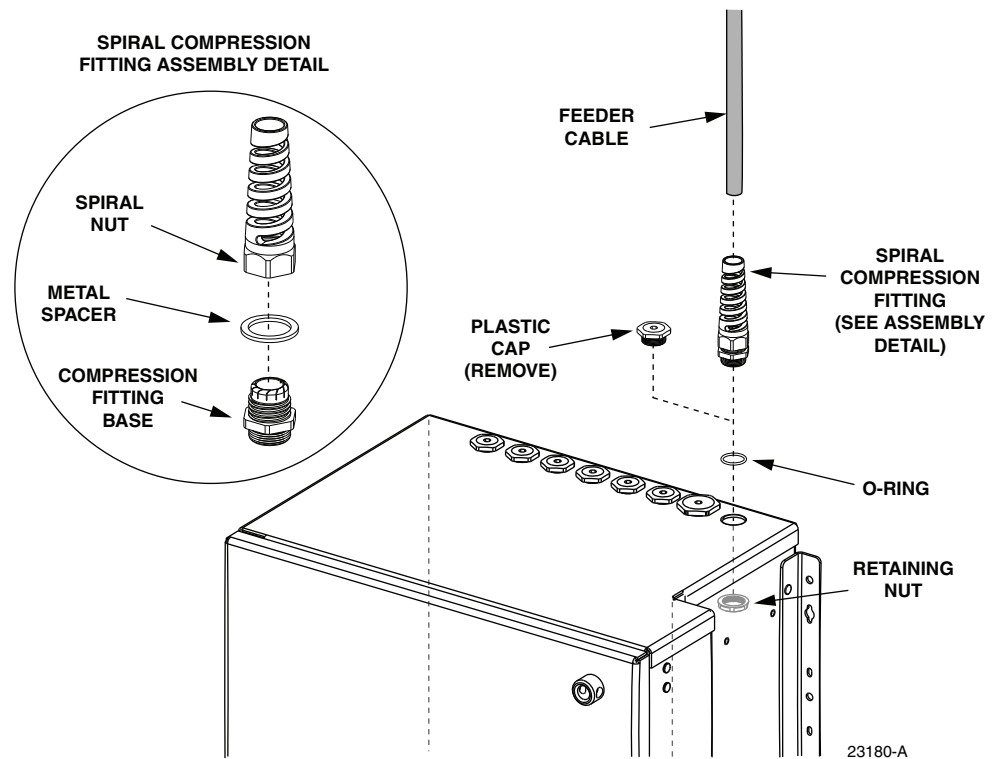

Figure 17. Plastic Cap Removal and Compression Fitting Installation

7. Slide the retaining nut (saved in step 2) over the end of the feeder cable and move it up to the cable entry/exit hole.
8. Insert the threaded end of the spiral compression fitting into the cable entry/exit hole and secure it to the cabinet with the retaining nut.
9. Strip back the feeder cable sheath **151 inches** (384 cm) to expose the fiber subunits or fiber ribbons.
10. Install breakout and cable grounding kits as required by local practice. Follow the installation instructions provided with each kit.
  - ▶ **Note:** A breakout kit is recommended when installing OSP ribbon cable. The breakout kit includes plastic tubes that protect the fiber ribbons and prevent damage. Instructions for trimming the plastic tubes to length are provided in [Section 6.3](#). A grounding kit is required if the cable is equipped with metallic shields or strength members. Install the cable grounding kit prior to securing the cable to the cabinet.
11. Adjust cable to remove any excess slack from the cabinet interior and then tighten the spiral nut to secure the feeder cable at the cable entry/exit hole.
12. Depending on the cabinet option, either a plastic or brass clamp will be provided with the cabinet. Assemble the cable clamp on the feeder cable as shown in [Figure 18](#).
  - ▶ **Note:** If a brass cable clamp is provided with the cabinet, the diameter of the feeder cable must be **0.51 inches** or the brass clamp will not retain the cable properly.

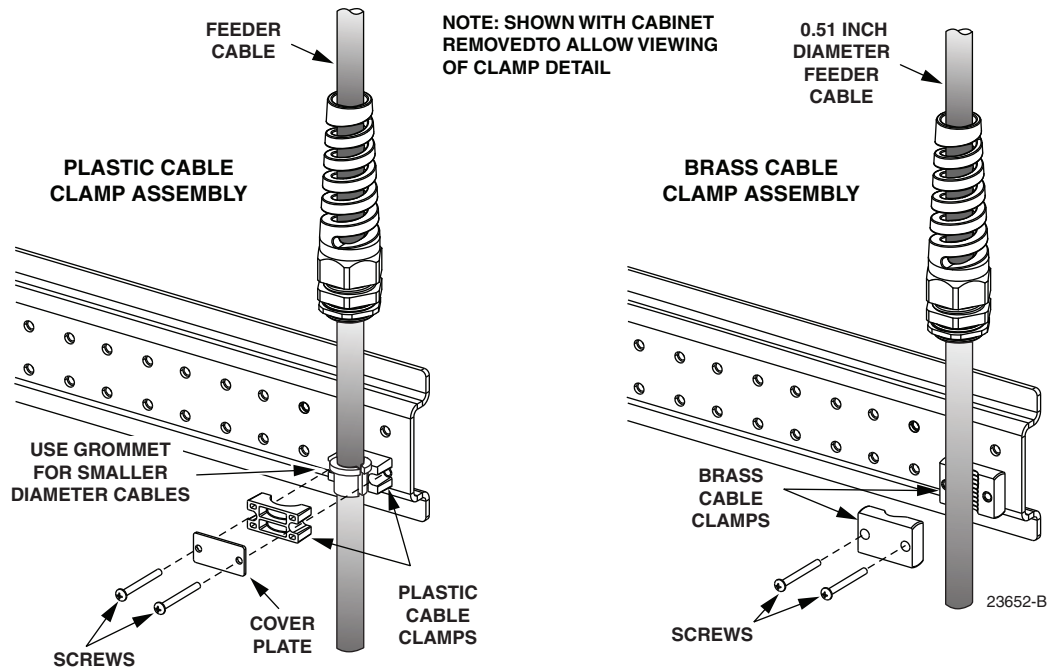

Figure 18. Assembling Feeder Cable Clamps

13. Use the cable clamp to secure the cable to the mounting bracket inside the cabinet. Tighten both clamp screws evenly. If the cabinet is equipped with a brass cable clamp, tighten clamp screws until both halves of the cable clamp are touching.
14. Carefully coil the exposed feeder cable fibers around the bottom of the cabinet where they will be out of the way until ready to begin splicing.
15. If a grounding kit was installed on the feeder cable, refer to [Section 6.2](#) for instructions on installing the cabinet grounding block kit and for connecting the grounding cable to the cabinet ground block. If a grounding kit was not required, refer to [Section 6.3](#) or [Section 6.4](#) for the splicing procedure.

## 6.2 Grounding Cables with Metallic Members

Cables equipped with metallic shields or strength members must be grounded. Both a **cable** grounding kit and a **cabinet** grounding block kit are required for cables that require grounding.

If a cable grounding kit was installed in the previous section, connect a #6 copper wire to the cable. Follow the instructions provided with the cable grounding kit to attach the grounding wire to the cable.

After the **cable** grounding kit is installed, use the following procedure to install the **cabinet** grounding block kit and to connect the cable grounding wire to the cabinet grounding block:

1. Locate the two studs in the upper right corner of the cabinet as shown in [Figure 19](#) and apply anti-seize compound to the threads.
2. Locate the cabinet grounding block (from accessory kit) and place it over the two studs.

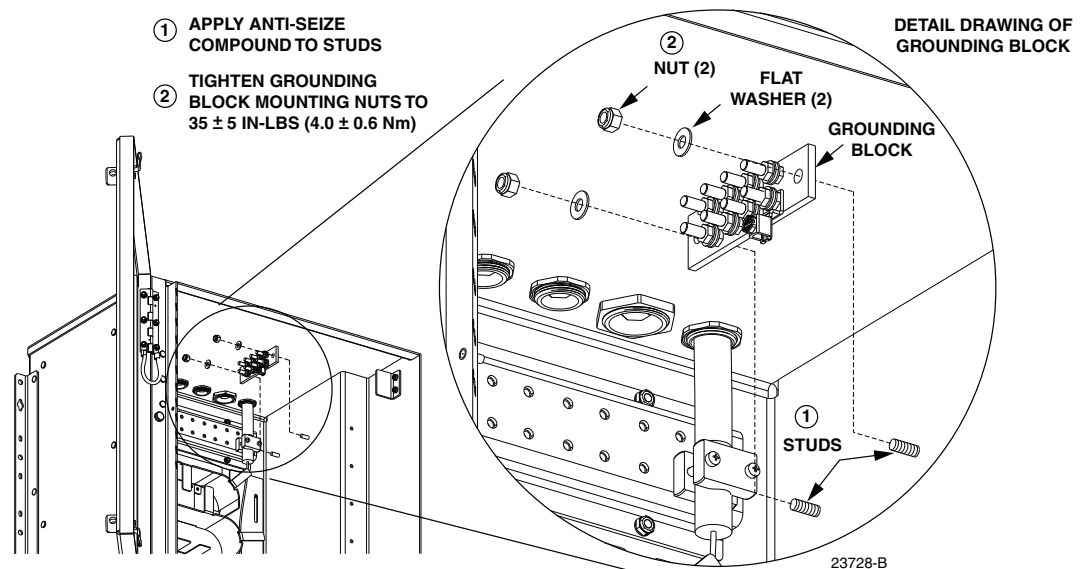

**Figure 19. Cabinet Grounding Block Kit Installation**

3. Install a flat washer and nut on each stud and then tighten each nut to  $35 \pm 5$  in-lbs ( $4.0 \pm 0.6$  Nm).
4. Route the cable grounding wire to the grounding block. The grounding block provides eight 10-32 grounding studs for the attachment of grounding wires.
5. Crimp a ring terminal (not provided) onto the end of the cable grounding wire.
6. Remove the protective plastic cap, nut, and flat washer from one of the grounding studs on the grounding block as shown in [Figure 20](#).

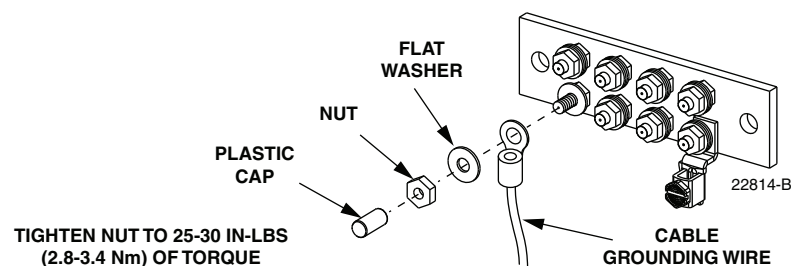

**Figure 20. Connecting Grounding Cable to Grounding Block**

7. Use the nut and flat washer removed in step 3 to secure the grounding wire ring terminal to the grounding block.
8. Tighten the grounding stud nut to 25 to 30 lbs-force inches (2.8 to 3.4 Nm) of torque.

### 6.3 Splicing the Feeder Cable Fibers to the Splitter Fibers - Ribbon Fiber

A single splice tray for splicing the feeder cable fibers to the splitter fibers is mounted at the bottom of the cabinet. The ribbon fiber splice tray can hold up to 72 splices. Use the following procedure to route and splice ribbon-type feeder cables:



1. Locate the feeder splice tray assembly which is mounted at the bottom of the cabinet, as shown in [Figure 21](#), and locate the splitter input fibers which are routed to the feeder splice tray.

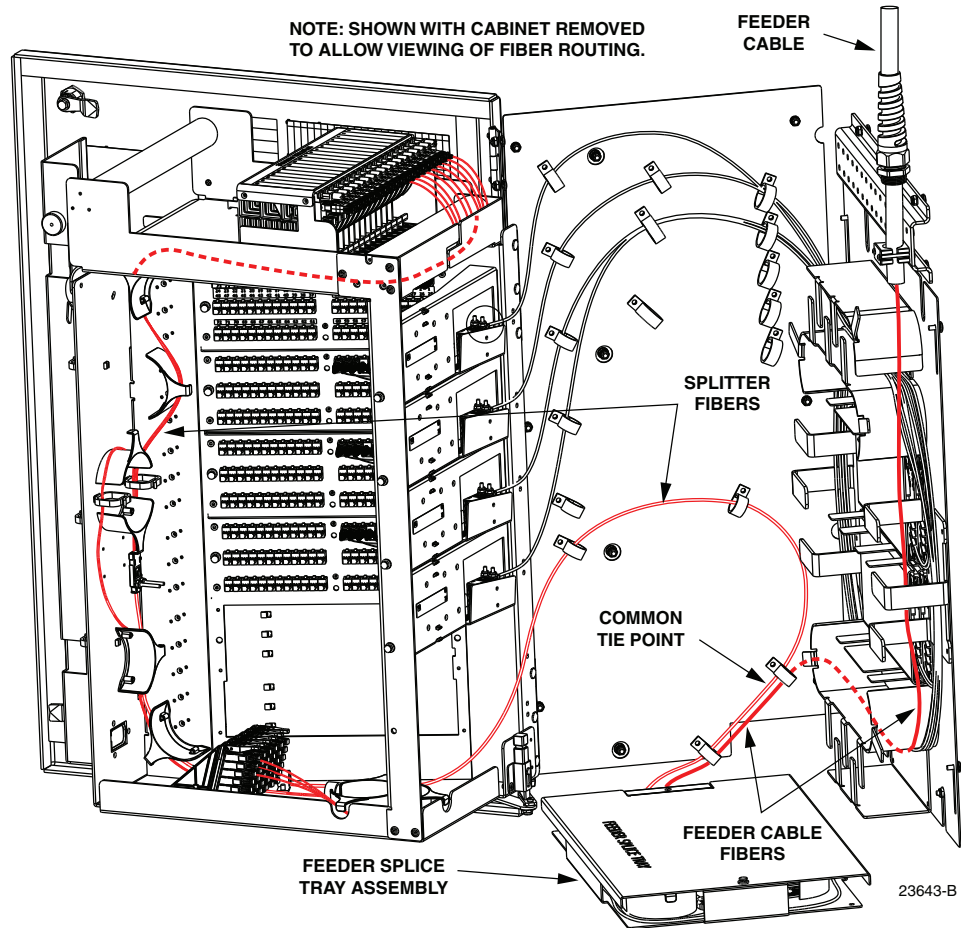

**Figure 21. Feeder Splice Tray and Feeder/Splitter Fiber Routing**

2. Lift the sheet metal cover away from the splice tray holder as shown in [Figure 22](#).
3. Unfasten the hook and pile strips that secure the tray in place and unwind the attached splitter fiber tubes from around the splice tray holder.
4. Beginning at the feeder cable ribbon breakout point shown in [Figure 23](#), route the protective tube or ribbon subunit to the intersect point with the splitter fibers.



**Caution:** Always allow sufficient fiber length to permit routing without severe bends. Non reduced bend radius fibers may be permanently damaged if bent or curved to a radius of less than 1.5 inches (3.81 cm).

5. Create a common tie point by securing the protective tube or ribbon subunit (use lacing or a cable tie) to the splitter fibers at the intersect point.
6. Route the protective tube or ribbon subunit to the splice tray and then remove the clear plastic cover from the splice tray.



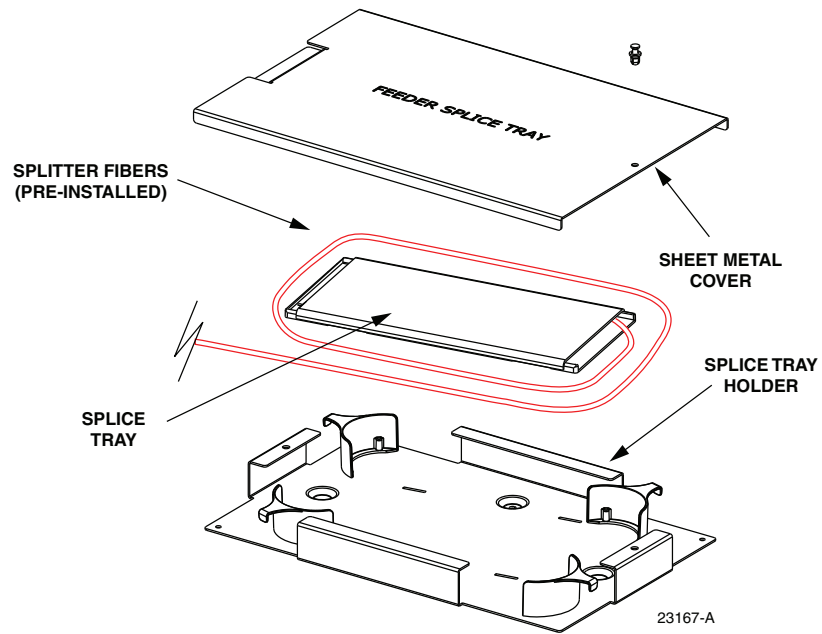

Figure 22. Feeder Slice Tray Assembly

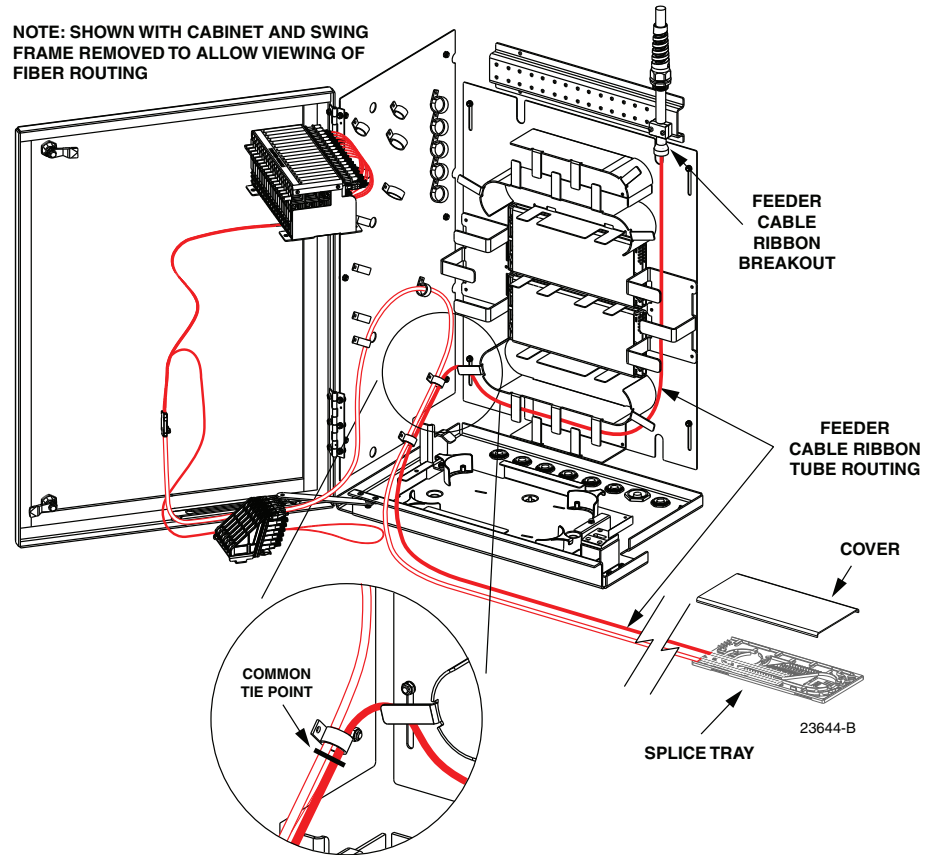

Figure 23. Feeder Fiber Routing to Splice Tray - Ribbon Cable

7. Cut the protective tube or the ribbon subunit tube (don't cut the fiber ribbons) to the **same length** as the splitter fiber tubes attached to the splice tray.
8. Use lacing or cable ties to secure the protective tube or ribbon subunit to the splice tray and verify that the feeder protective tube is the same length as the attached splitter fiber tubes. Adjust as needed to make the lengths equal.



**Caution:** *Improper handling can damage fiber optic cables. Do not over tighten cable ties or lacing as this can cause damage or attenuation. Do not compress the fibers or allow them to kink.*

9. From the tie point on the splice tray, trim the **feeder fibers** to a cut length of 28 inches (71 cm) and the **splitter fibers** to a cut length of 36 inches (92 cm).
10. Splice the feeder cable fibers to the appropriate splitter fibers as specified by local policies and procedures. Adjust and route the fibers within the splice tray as shown in [Figure 24](#). Refer to [Table 3](#) for the splitter fiber designations.

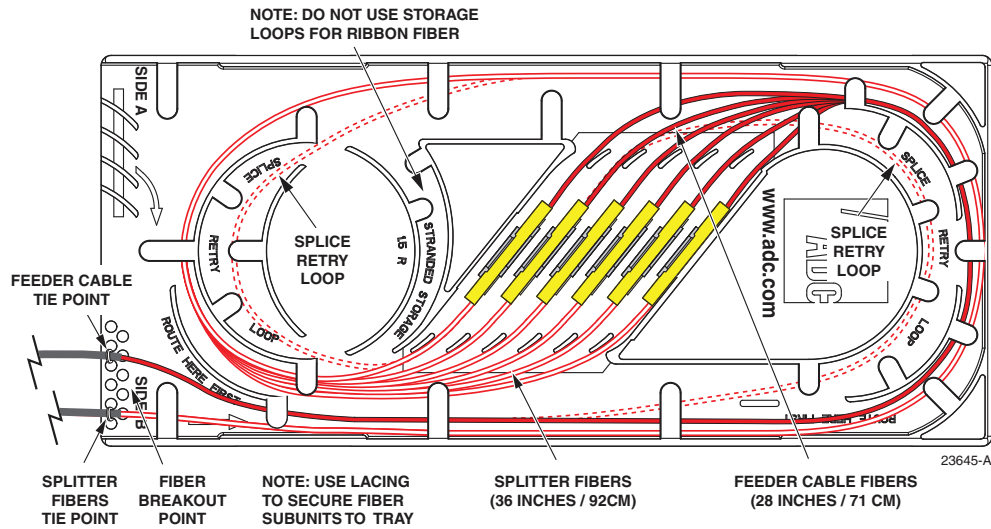
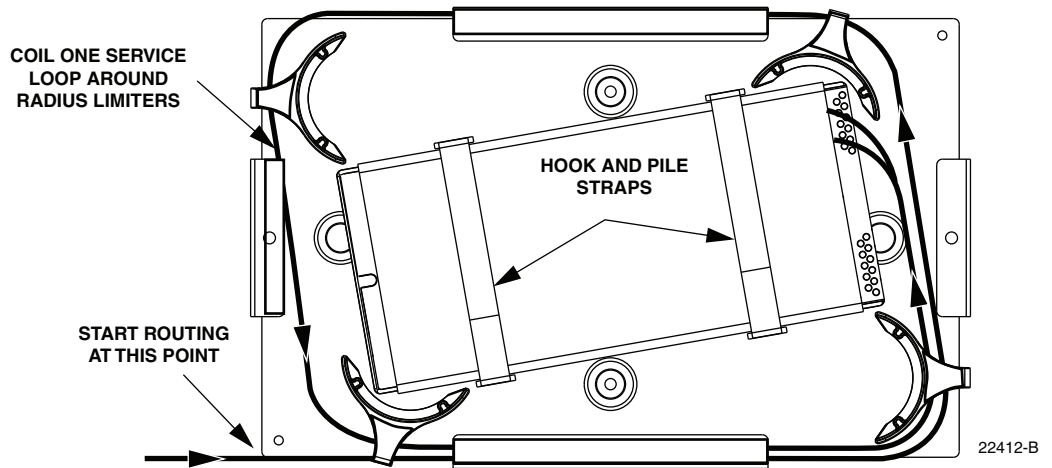

**Figure 24. Ribbon Fiber Splice Tray - Feeder Cable Splicing**

11. After splicing is completed, re-install the clear plastic cover on the splice tray.
12. To replace the splice tray, route the attached tubes around the splice tray holder radius limiters (there should be two service loops) as shown in [Figure 25](#). Avoid twisting or kinking the fiber tubes. Maintain a 1.5-inch (3.81 cm) minimum bend radius for all non reduced bend radius fiber.
13. Secure the splice tray to the splice tray holder using the hook and pile strips.
14. Re-install the sheet metal cover on the splice tray holder.
15. Close swing frame and the cabinet door when splicing is finished.

**Table 3. Splitter and Spare Fiber Port Designations for 12-, 24-, and 48-Fiber Feeder Cables**

RIBBON/ SUBUNIT	FIBER	SPLITTE R PORT	SPARE PORT	RIBBON/ SUBUNIT	FIBER	SPLITTE R PORT	SPARE PORT
1	1 (Blue)	1	–	3	1 (Blue)	–	25
	2 (Orange)	2	–		2 (Orange)	–	26
	3 (Green)	3	–		3 (Green)	–	27
	4 (Brown)	4	–		4 (Brown)	–	28
	5 (Slate)	5	–		5 (Slate)	–	29
	6 (White)	6	–		6 (White)	–	30
	7 (Red)	7	–		7 (Red)	–	31
	8 (Black)	8	–		8 (Black)	–	32
	9 (Yellow)	9	–		9 (Yellow)	–	33
	10 (Violet)	10	–		10 (Violet)	–	34
	11 (Rose)	11	–		11 (Rose)	–	35
	12 (Aqua)	12	–		12 (Aqua)	–	36
2	1 (Blue)	13	–	4	1 (Blue)	–	37
	2 (Orange)	14	–		2 (Orange)	–	38
	3 (Green)	15	–		3 (Green)	–	39
	4 (Brown)	16	–		4 (Brown)	–	40
	5 (Slate)	17	–		5 (Slate)	–	41
	6 (White)	18	–		6 (White)	–	42
	7 (Red)	–	19		7 (Red)	–	43
	8 (Black)	–	20		8 (Black)	–	44
	9 (Yellow)	–	21		9 (Yellow)	–	45
	10 (Violet)	–	22		10 (Violet)	–	46
	11 (Rose)	–	23		11 (Rose)	–	47
	12 (Aqua)	–	24		12 (Aqua)	–	48

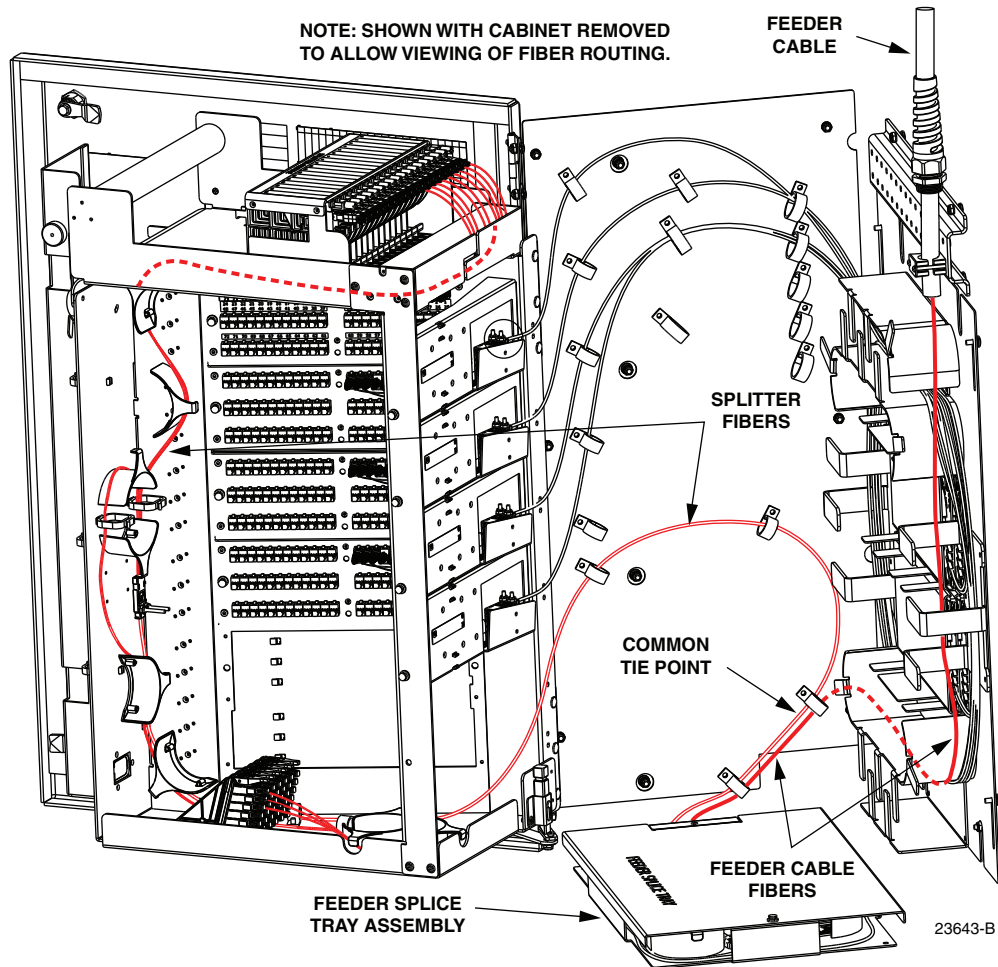

**Figure 25. Feeder Splice Tray Replacement**

## 6.4 Splicing the Feeder Cable Fibers to the Splitter Fibers - Stranded Fiber

A splice tray for splicing the feeder cable fibers to the splitter fibers is mounted at the bottom of the cabinet. The stranded fiber splice tray can hold up to 36 splices. Use the following procedure to route and splice stranded-type feeder cables:

1. Locate the feeder splice tray which is mounted at the bottom of the cabinet, as shown in [Figure 26](#), and locate the splitter fibers which are routed to the feeder splice tray.

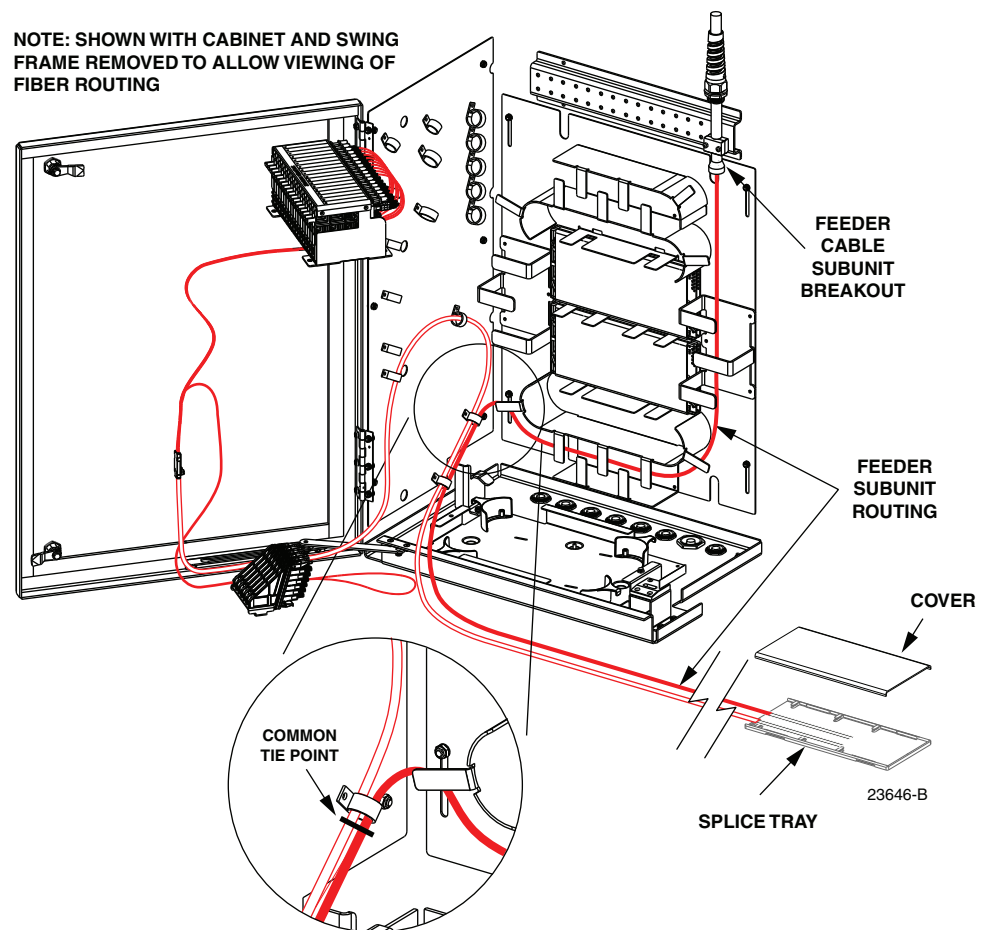

**Figure 26. Feeder Splice Tray and Feeder/Splitter Fiber Routing**

2. Lift the sheet metal cover (See [Figure 22](#)) away from the splice tray holder.
3. Unfasten the hook and pile strips that secure the tray in place and unwind the attached splitter fibers from around the splice tray assembly.
4. Beginning at the feeder cable subunit breakout point shown in [Figure 27](#), route the feeder cable fibers to the intersect point with the splitter fibers.



**Caution:** Always allow sufficient fiber length to permit routing without severe bends. Non reduced bend radius fibers may be permanently damaged if bent/curved to a radius of less than 1.5 inches (3.81 cm).



**Figure 27. Feeder Fiber Routing To Splice Tray - Stranded Cable**

5. Create a common tie point by securing the feeder cable subunits (use lacing or cable ties) to the splitter subunits at the intersect point.
6. Route the feeder cable subunits to the splice tray and then remove the clear plastic cover from the splice tray.
7. Use lacing or cable ties to secure the feeder cable subunits to the splice tray and verify that the feeder subunits are the same length as the attached splitter subunits. Adjust as needed to make the lengths equal.



**Caution:** *Improper handling can damage fiber optic cables. Do not over tighten cable ties or lacing as this can cause damage or attenuation. Do not compress the fibers or allow it to kink.*

8. From the tie point on the splice tray, trim the **feeder fibers** to a cut length of 28 inches (71 cm) and the **splitter fibers** to a cut length of 36 inches (92 cm).
9. Within the splice tray, remove the subunit tubes from the distribution cable fibers to expose the bare individual optical fibers.

10. Splice the feeder cable fibers to the appropriate splitter fibers as specified by local policies and procedures. Adjust and route the fibers within the splice tray as shown in [Figure 28](#). Refer to [Table 3](#) (See Section 6.3) for the splitter fiber designations.

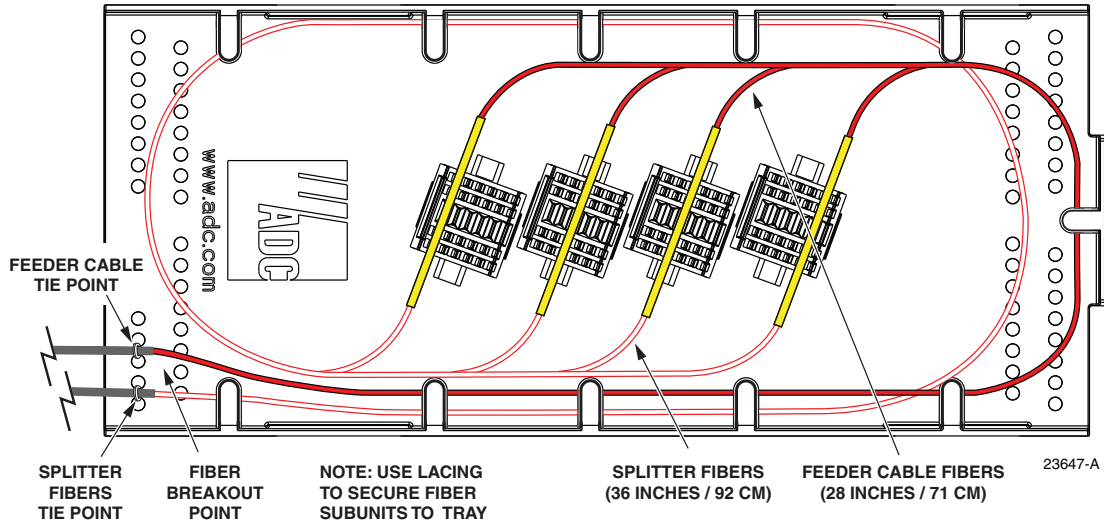

**Figure 28. Stranded Fiber Splice Tray - Feeder Cable Splicing**

11. After splicing is completed, re-install the clear plastic cover on the splice tray. I
12. To replace the splice tray, route the attached subunits (there should be two service loops) around the splice tray holder radius limiters (see [Figure 25](#)). Avoid twisting or kinking the fiber subunit tubes. Maintain a 1.5-inch (3.81 cm) minimum bend radius for all non reduced bend radius fiber.
13. Secure the splice tray to the splice tray holder using the hook and pile strips.
14. Re-install the sheet metal cover on the splice tray holder.
15. Close the swing frame and the cabinet door when splicing is finished.

## 7 DISTRIBUTION CABLE INSTALLATION AND SPLICING

The indoor 288 cabinet may be ordered with or without factory-installed distribution cables. This section describes how to install distribution cables in cabinets that are not equipped with pre-installed distribution cables. Also covered are procedures for splicing distribution cable fibers to the distribution panel fiber subunits. Distribution cables enter/exit the cabinet from the top.

### 7.1 Distribution Cable Installation

A compression fitting is used to secure each cable at the entry/exit point to the cabinet. Within the cabinet, a cable clamp is used to secure each cable to a bracket. Beyond the clamp, the outer sheath of each cable is removed to expose the optical fibers. The distribution cable is typically a 72-, 144-, or 288-fiber cable with stranded or ribbon fiber construction. Breakout kits should be installed (subject to local practice) to protect exposed optical fibers. Grounding kits should be installed on cables with metallic elements. From the clamping point, the optical fibers are routed to splice trays for splicing to the distribution panel fibers.

Use the following procedure to install each distribution cable:

1. Locate the cable entry/exit holes (on top of the cabinet) that are specified for distribution cable installation as shown in [Figure 29](#).

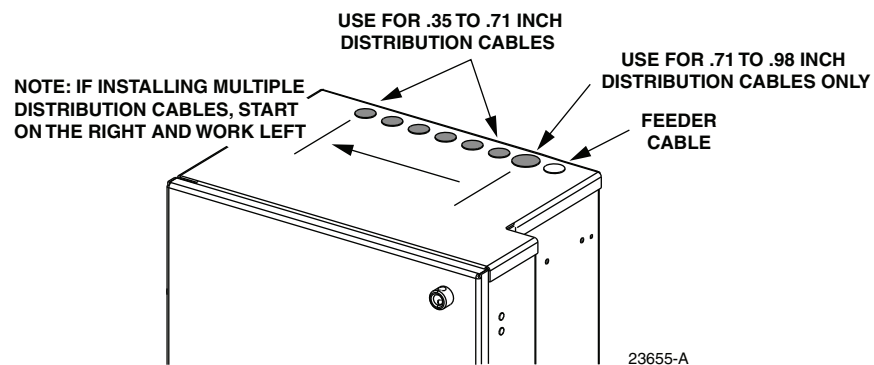

**Figure 29. Cable Entry/Exit Holes**

2. Open the cabinet door and swing frame to provide access to the interior of the cabinet.
  3. Remove the plastic cap and retaining nut from the selected cable entry/exit hole as shown in [Figure 30](#). Save the retaining nut for reuse.
  4. Locate the compression fitting that is shipped with the cabinet and then loosely assemble the compression fitting components (see [Figure 30](#)).
- **Note:** A large compression fitting for 0.71 to 0.98 inch cables is shipped with the cabinet. If the distribution cable is less than 0.71 inches in diameter, compression fittings for smaller diameter cables may be obtained by ordering kit FD3-ACCMSPCLMP.
5. Slide the compression fitting and O-ring over the end of the distribution cable. Loosen the compression fitting nut if it does not slide freely over the cable.
  6. Insert the end of the distribution cable into the cable entry/exit hole and pull through about **10 feet** (3 meters) of cable slack.



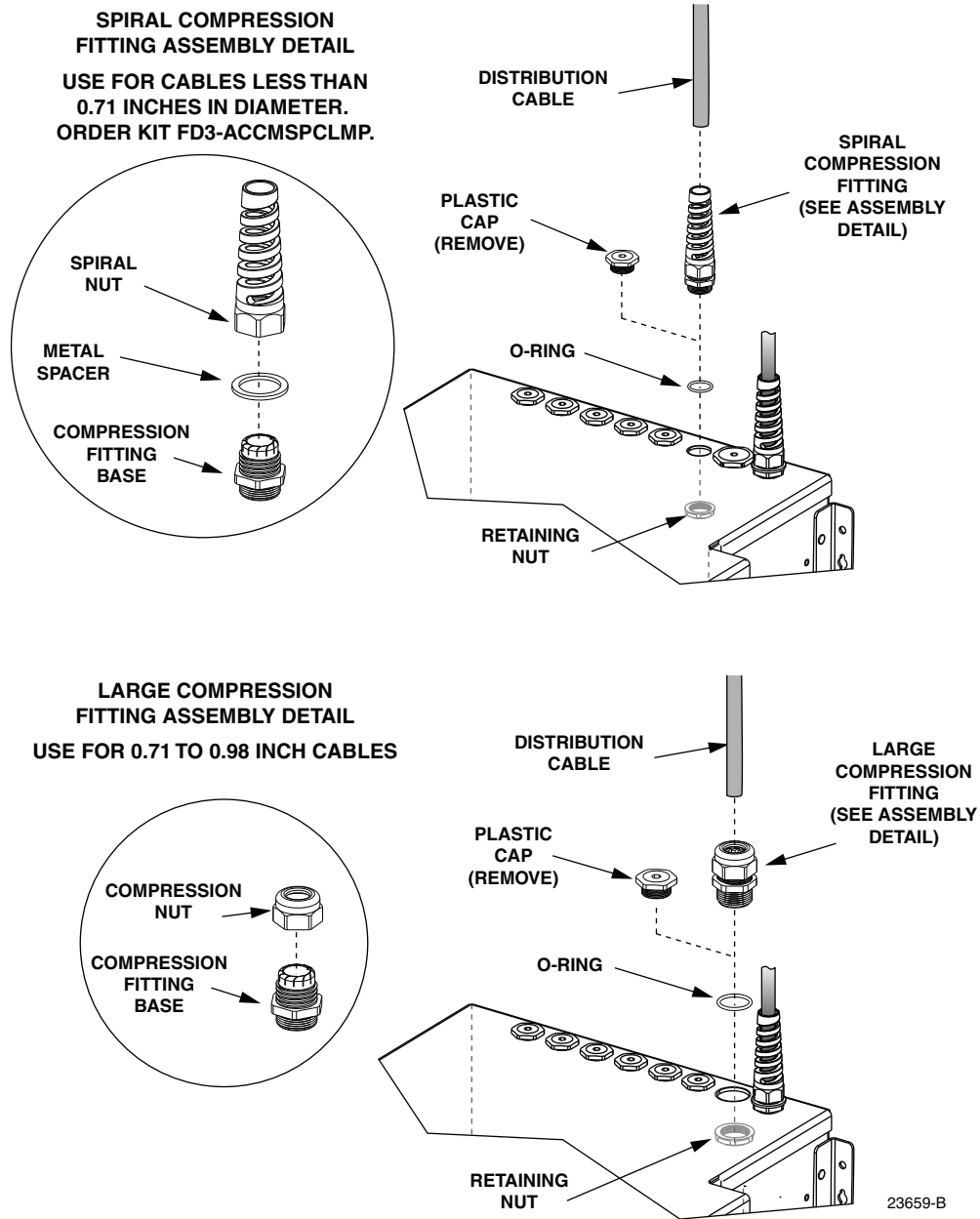

Figure 30. Plastic Cap Removal and Compression Fitting Installation

7. Slide the retaining nut (saved in step 2) over the end of the distribution cable and move it up to the cable entry/exit hole.
8. Insert the threaded end of the compression fitting into the cable entry/exit hole and secure it to the cabinet with the retaining nut.
9. Strip back the distribution cable sheath **118 inches (300 cm)** to expose the fiber subunits or fiber ribbons.



10. Install breakout and cable grounding kits as required by local practice. Follow the installation instructions provided with each kit.
- **Note:** A breakout kit is recommended when installing ribbon cable. The breakout kit includes plastic tubes that protect the fiber ribbons and prevent damage. Instructions for trimming the plastic tubes to length are provided in [Section 7.2](#). A cable grounding kit is required if the cable is equipped with metallic shields or strength members. Install the cable grounding kit prior to securing the cable to the cabinet.
11. Adjust cable to remove any excess slack from the cabinet interior and then tighten the compression fitting nut to secure the distribution cable at the cable entry/exit hole.
  12. Assemble the cable clamp (provided with cabinet) and grommet (if needed) on the distribution cable as shown in [Figure 31](#).

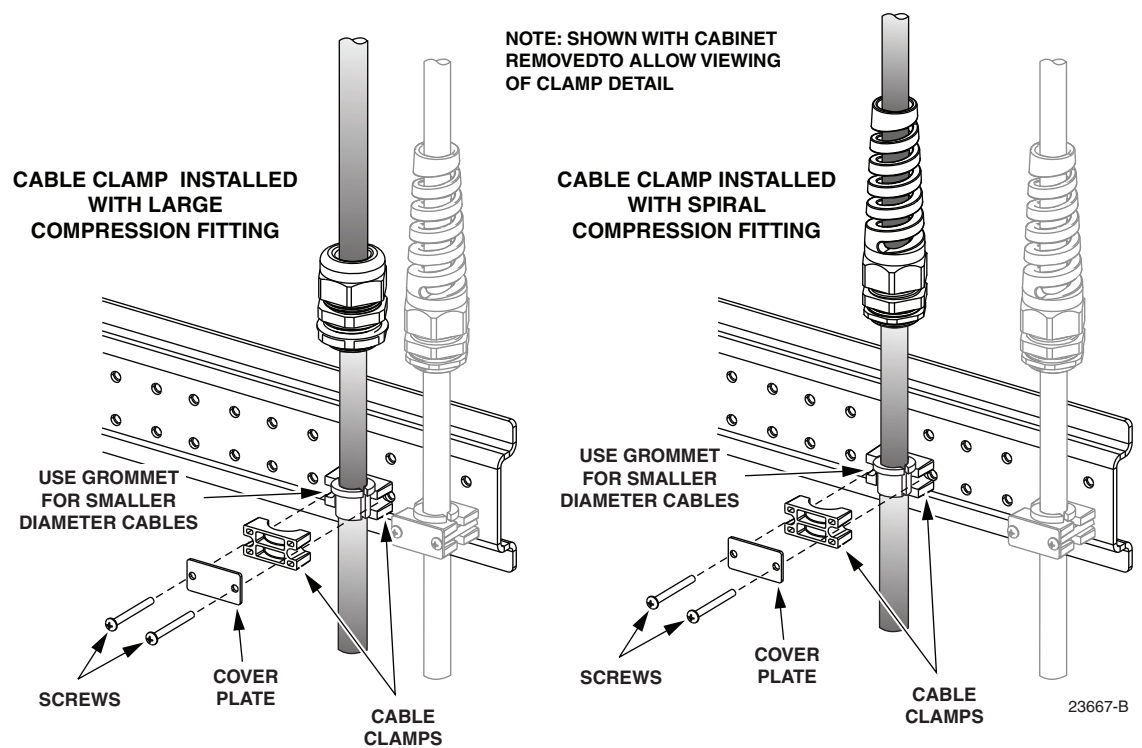

Figure 31. Assembling Distribution Cable Clamp

13. Use the cable clamp to secure the cable to the mounting bracket inside the cabinet.
14. Carefully coil the exposed distribution cable fibers around the bottom of the cabinet where they will be out of the way until ready to begin splicing.
15. Grounding kits are not usually required for distribution cables. However, if a grounding kit was installed, refer to [Section 6.2](#) for instructions on installing a cabinet ground block kit and for connecting the grounding cable to the cabinet ground block. If a grounding kit was not required, refer to [Section 7.2](#) or [Section 7.3](#) for the splicing procedure.

## 7.2 Splicing the Distribution Cable Fibers to the Distribution Panel Pigtails - Ribbon Fiber

Splice trays for splicing the distribution cable fibers to the distribution panel fibers are mounted at the back of the cabinet. One splice tray is provided for each distribution panel. Each ribbon fiber splice tray can hold up to 72 mass fusion splices. Use the following procedure to route and splice ribbon-type distribution cables:

1. Locate the distribution splice tray assembly which is mounted at the back of the cabinet, as shown in [Figure 32](#). Trace the routing of the distribution panel fibers and identify each splice tray and the corresponding distribution panel.

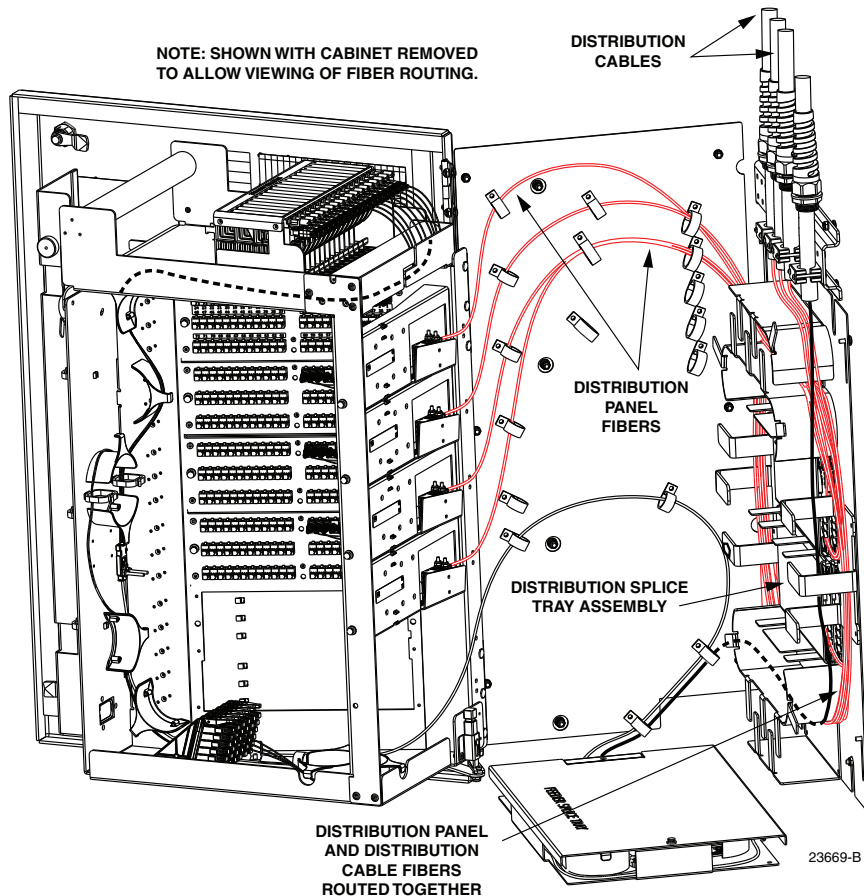

**Figure 32. Distribution Splice Trays and Distribution Panel Fiber Routing – Ribbon**

2. Locate the appropriate splice tray for splicing the distribution cable fibers.
3. Unfasten the hook and pile strips that secure the tray in place and unwind the attached fiber tubes from around the distribution splice tray assembly as shown in [Figure 33](#).
4. Beginning at the distribution cable ribbon breakout point shown in [Figure 34](#), route the protective tube or ribbon subunit to the intersect point with the distribution panel fibers.



**Caution:** Always allow sufficient fiber length to permit routing without severe bends. Non reduced bend radius fibers may be permanently damaged if bent/curved to a radius of less than 1.5 inches (3.81 cm).

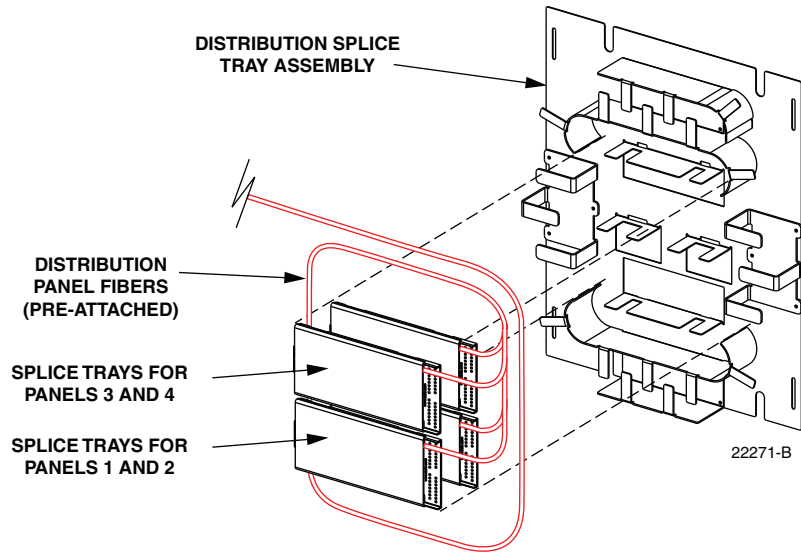

Figure 33. Distribution Splice Tray Assembly – Ribbon Cable

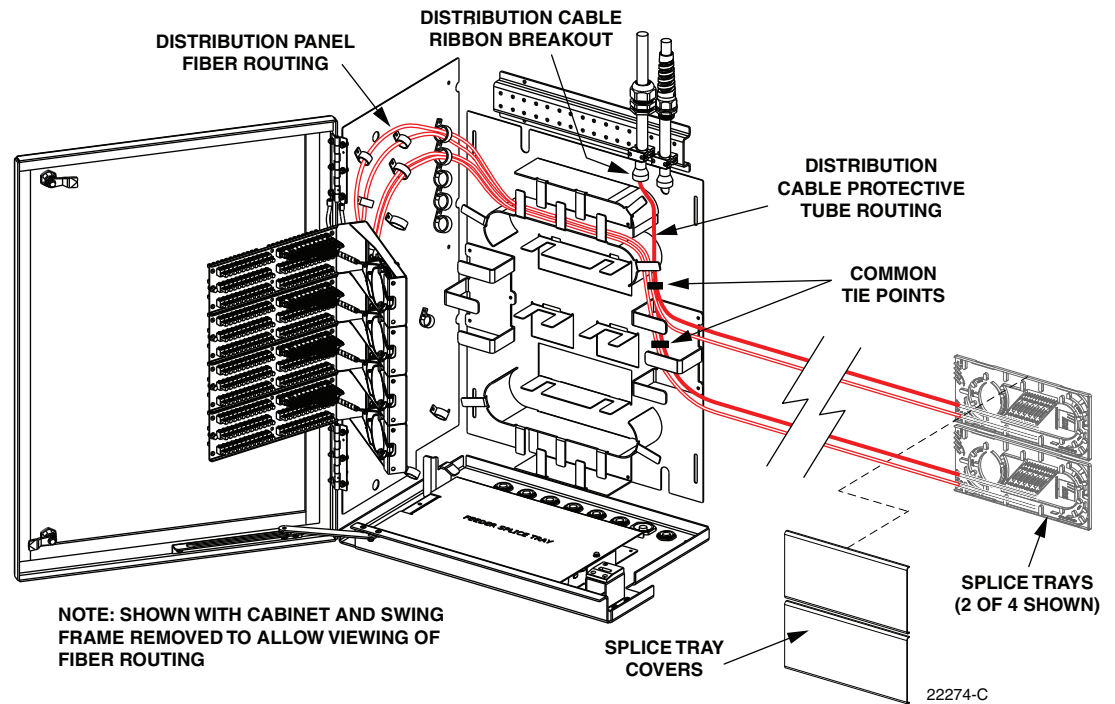

Figure 34. Distribution Fiber Routing – Ribbon Cable

5. Create a common tie point by securing the protective tube or ribbon subunit (use lacing or cable ties) to the distribution panel fibers at the intersect point.
6. Route the protective tube or ribbon subunit to the splice tray and then remove the clear plastic cover from the splice tray.

7. Cut the protective tube or the ribbon subunit tube (don't cut the fiber ribbons) to the **same length** as the distribution panel tube attached to the splice tray.
8. Use lacing or cable ties to secure the protective tube or ribbon subunit to the splice tray and verify that the distribution cable protective tube is the same length as the attached distribution panel fiber tubes. Adjust as needed to make the lengths equal.



**Caution:** *Improper handling can damage fiber optic cables. Do not over tighten cable ties or lacing as this can cause damage or attenuation. Do not compress the fibers or allow it to kink.*

9. From the tie point on the splice tray, trim the **distribution cable fibers** to a cut length of 28 inches (71 cm) and the **distribution panel fibers** to a cut length of 36 inches (92 cm).
10. Splice the distribution cable fibers to the appropriate distribution panel fibers as specified by local policies and procedures. Adjust and route the fibers within the splice tray as shown in [Figure 35](#). Refer to [Table 4](#) for the distribution panel fiber designations.

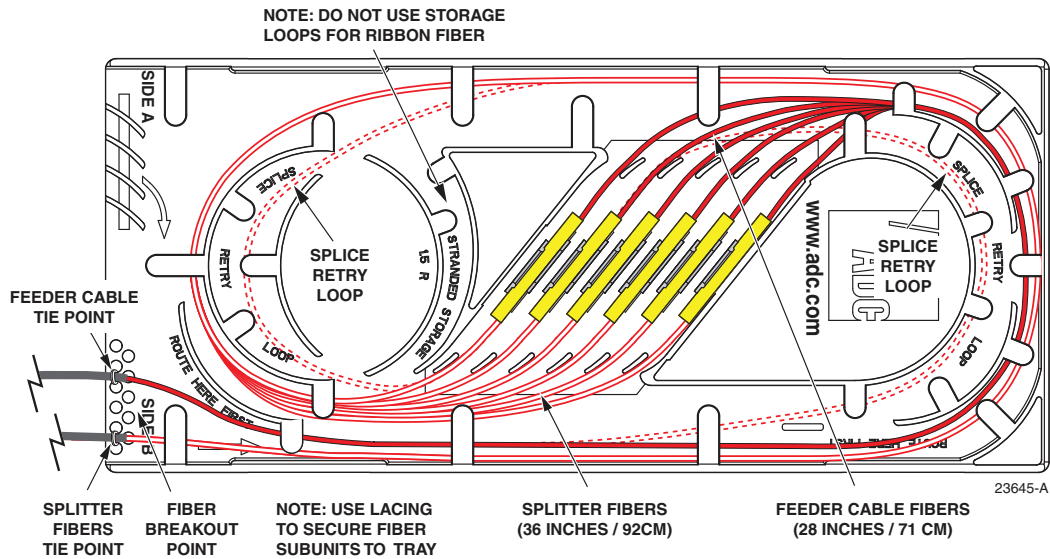

**Figure 35. Ribbon Fiber Splice Tray - Distribution Cable Splicing**

11. After splicing is completed, re-install the clear plastic cover on the splice tray.
12. To replace the splice tray, route the attached tubes around the distribution splice tray assembly as shown in [Figure 36](#). Avoid twisting or kinking the fiber tubes. Maintain a 1.5-inch (3.81 cm) minimum bend radius for all non reduced bend radius fiber.
13. Secure the splice tray to the splice tray assembly using the hook and pile strips.
14. Repeat steps 3 through 13 for each distribution panel.
15. Close swing frame and the cabinet door when splicing is finished.

**Table 4. Distribution Panel Fiber Designations – Ribbon Cable**

RIBBON	FIBER	COLOR	SPLICE TRAY	RIBBON	FIBER	COLOR	SPLICE TRAY
1	1	Blue	Tray 1 if Panel 1	4	37	Blue	Tray 1 if Panel 1
	2	Orange			38	Orange	
	3	Green			39	Green	
	4	Brown			40	Brown	
	5	Slate	Tray 2 if Panel 2		41	Slate	
	6	White			42	White	
	7	Red	Tray 3 if Panel 3		43	Red	
	8	Black			44	Black	
	9	Yellow	Tray 4 if Panel 4		45	Yellow	
	10	Violet			46	Violet	
	11	Rose			47	Rose	
	12	Aqua			48	Aqua	
2	13	Blue	Tray 1 if Panel 1	5	49	Blue	Tray 1 if Panel 1
	14	Orange			50	Orange	
	15	Green			51	Green	
	16	Brown			52	Brown	
	17	Slate	Tray 2 if Panel 2		53	Slate	
	18	White			54	White	
	19	Red	Tray 3 if Panel 3		55	Red	
	20	Black			56	Black	
	21	Yellow	Tray 4 if Panel 4		57	Yellow	
	22	Violet			58	Violet	
	23	Rose			59	Rose	
	24	Aqua			60	Aqua	
3	25	Blue	Tray 1 if Panel 1	6	61	Blue	Tray 1 if Panel 1
	26	Orange			62	Orange	
	27	Green			63	Green	
	28	Brown			64	Brown	
	29	Slate	Tray 2 if Panel 2		65	Slate	
	30	White			66	White	
	31	Red	Tray 3 if Panel 3		67	Red	
	32	Black			68	Black	
	33	Yellow	Tray 4 if Panel 4		69	Yellow	
	34	Violet			70	Violet	
	35	Rose			71	Rose	
	36	Aqua			72	Aqua	

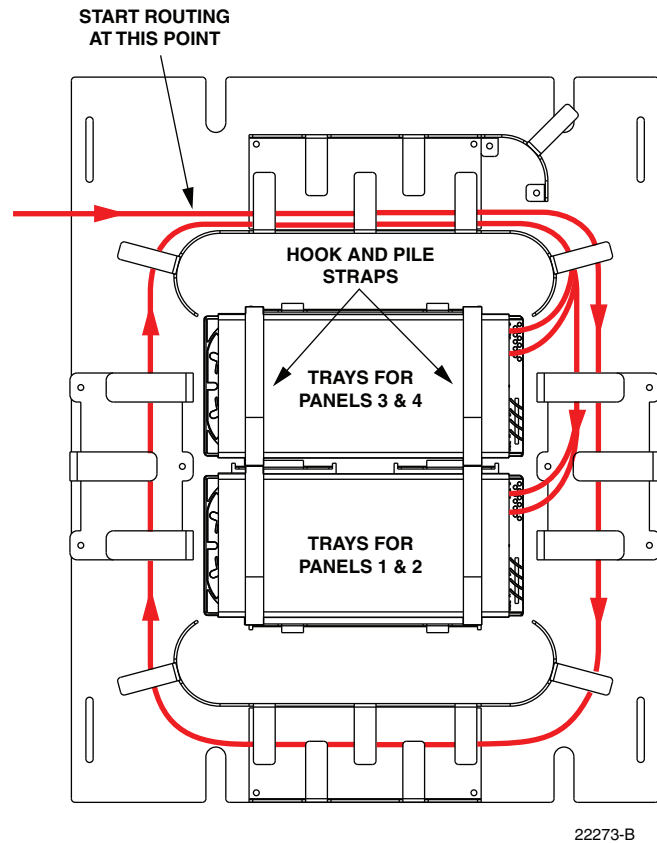

Figure 36. Distribution Splice Tray Replacement

### 7.3 Splicing the Distribution Cable Fibers to the Distribution Panel Pigtails - Stranded Fiber

Splice trays for splicing the distribution cable fibers to the distribution panel fibers are mounted at the back of the cabinet. Two splice trays are provided for each distribution panel. Each stranded fiber splice tray can hold up to 36 splices. Use the following procedure to route and splice stranded-type distribution cables:

1. Locate the distribution splice tray assembly which is mounted at the back of the cabinet, as shown in [Figure 37](#). Trace the routing of the distribution panel fibers and identify each splice tray and the corresponding distribution panel.
2. Locate the appropriate splice tray for splicing the distribution cable fibers.
3. Unfasten the hook and pile strips that secure the tray in place and unwind the attached fiber tubes from around the distribution splice tray assembly as shown in [Figure 38](#).
4. Beginning at the distribution cable fiber breakout point shown in [Figure 39](#), route the distribution cable subunits to the intersect point with the distribution panel fibers.



**Caution:** Always allow sufficient fiber length to permit routing without severe bends. Non reduced bend radius fibers may be permanently damaged if bent/curved to a radius of less than 1.5 inches (3.81 cm).

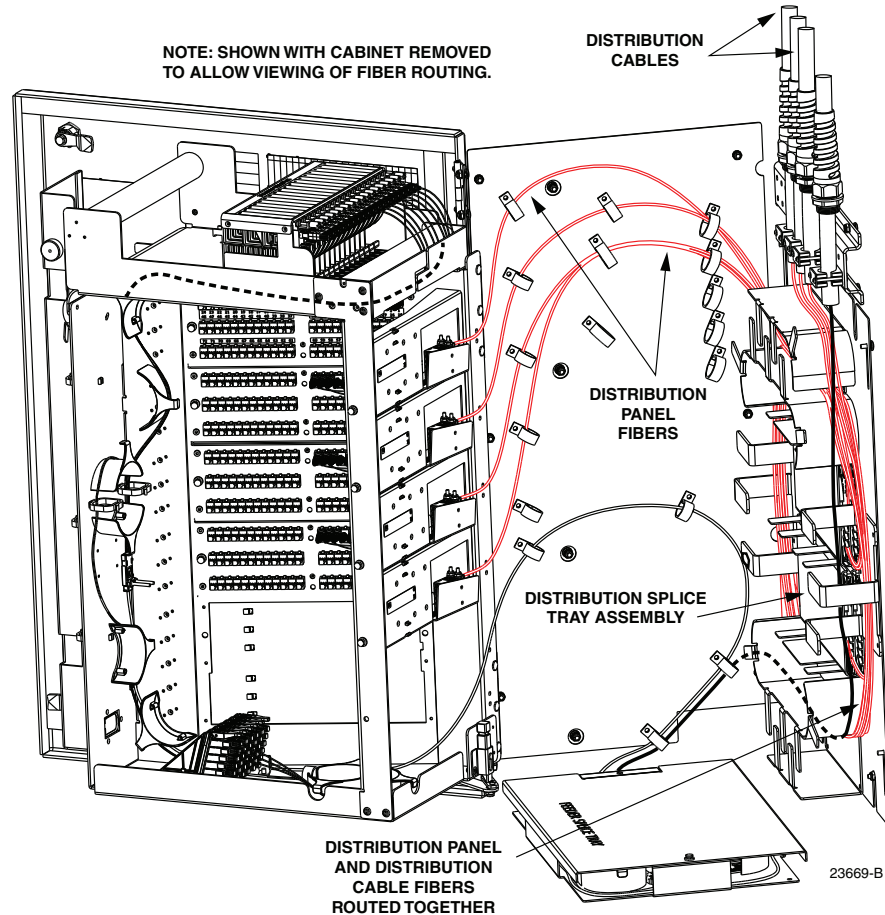

**Figure 37. Distribution Splice Trays and Distribution Panel Fiber Routing – Stranded**



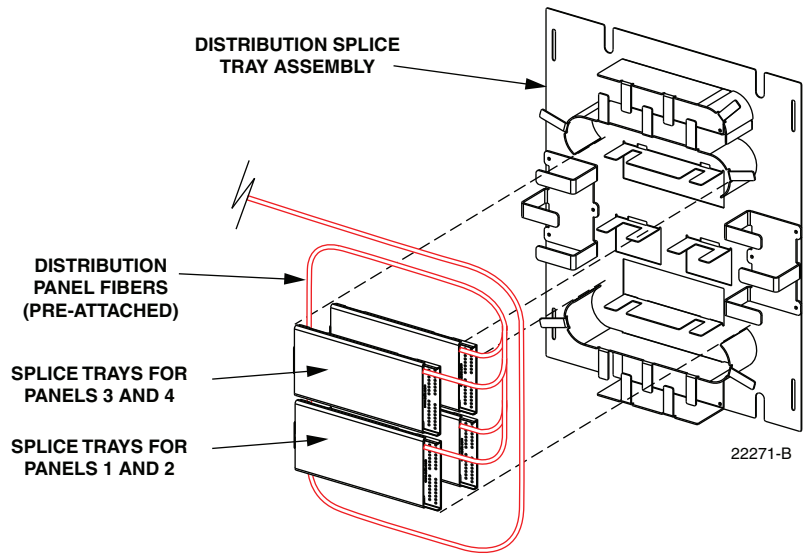

Figure 38. Distribution Splice Tray Assembly – Stranded Cable

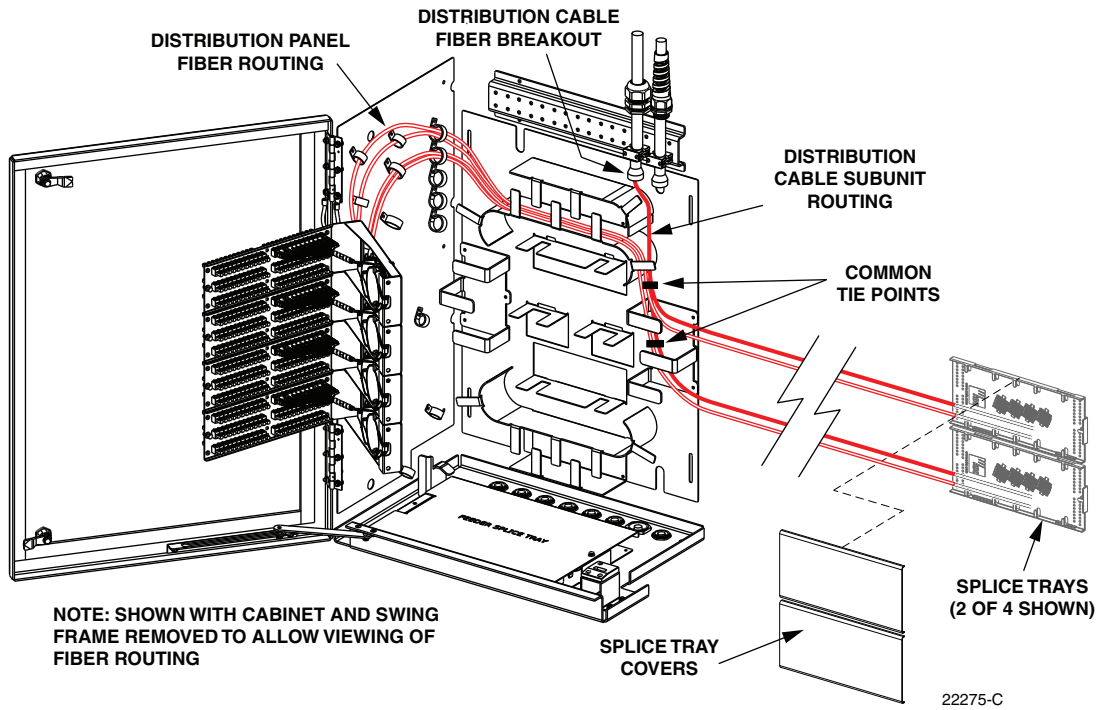

Figure 39. Distribution Fiber Routing – Stranded Cable

5. Create a common tie point by securing the distribution cable subunits (use lacing or cable ties) to the distribution panel fibers at the intersect point.
6. Route the distribution cable subunits to the splice tray and then remove the clear plastic cover from the splice tray.



7. Use lacing or cable ties to secure the distribution cable subunits to the splice tray and verify that the distribution cable subunits are the same length as the attached distribution panel fiber tubes. Adjust as needed to make the lengths equal.



**Caution:** *Improper handling can damage fiber optic cables. Do not over tighten cable ties or lacing as this can cause damage or attenuation. Do not compress the fibers or allow it to kink.*

8. From the tie point on the splice tray, trim the **distribution cable fibers** to a cut length of 28 inches (71 cm) and the **distribution panel fibers** to a cut length of 36 inches (92 cm).
9. Within the splice tray, remove the subunit tubes from the distribution cable fibers to expose the bare individual optical fibers.
10. Splice the distribution cable fibers to the appropriate distribution panel fibers as specified by local policies and procedures. Adjust and route the fibers within the splice tray as shown in [Figure 40](#). Refer to [Table 5](#) for the distribution panel fiber designations.
11. After splicing is completed, re-install the clear plastic cover on the splice tray.

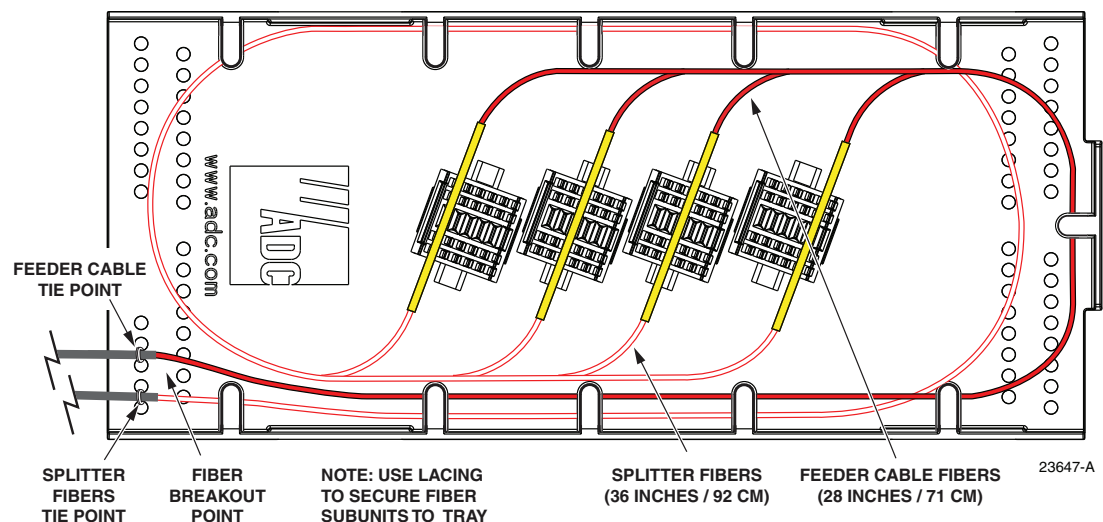

**Figure 40. Stranded Fiber Splice Tray - Distribution Cable Splicing**

12. To replace the splice tray, route the attached distribution cable fibers and distribution panel fibers (see [Figure 36](#)) around the splice tray assembly radius limiters. Avoid twisting or kinking the fiber tubes. Maintain a 1.5-inch (3.81 cm) minimum bend radius for all non reduced bend radius fiber.
13. Secure the splice tray to the splice tray assembly using the hook and pile strips.
14. Repeat steps 3 through 13 for each distribution panel.
15. Close swing frame and the cabinet door when splicing is finished.

**Table 5. Distribution Panel Fiber Designations – Stranded Cable**

SUBUNIT	FIBER	COLOR	SPLICE TRAY	SUBUNIT	FIBER	COLOR	SPLICE TRAY		
1	1	Blue	Tray 1 if Panel 1	4	37	Blue	Tray 2 if Panel 1		
	2	Orange			38	Orange			
	3	Green			39	Green			
	4	Brown	Tray 3 if Panel 2		40	Brown	Tray 4 if Panel 2		
	5	Slate	Tray 5 if Panel 3		41	Slate	Tray 6 if Panel 3		
	6	White			42	White			
	7	Red	Tray 7 if Panel 4		43	Red	Tray 8 if Panel 4		
	8	Black			44	Black			
	9	Yellow			45	Yellow			
	10	Violet			46	Violet			
	11	Rose			47	Rose			
	12	Aqua			48	Aqua			
2	13	Blue		Tray 1 if Panel 1	5	49		Blue	Tray 2 if Panel 1
	14	Orange				50		Orange	
	15	Green	51			Green			
	16	Brown	Tray 3 if Panel 2	52		Brown	Tray 4 if Panel 2		
	17	Slate	Tray 5 if Panel 3	53		Slate	Tray 6 if Panel 3		
	18	White		54		White			
	19	Red	Tray 7 if Panel 4	55		Red	Tray 8 if Panel 4		
	20	Black		56		Black			
	21	Yellow		57		Yellow			
	22	Violet		58		Violet			
	23	Rose		59		Rose			
	24	Aqua		60		Aqua			
3	25	Blue		Tray 1 if Panel 1	6	61		Blue	Tray 2 if Panel 1
	26	Orange				62		Orange	
	27	Green	63			Green			
	28	Brown	Tray 3 if Panel 2	64		Brown	Tray 4 if Panel 2		
	29	Slate	Tray 5 if Panel 3	65		Slate	Tray 6 if Panel 3		
	30	White		66		White			
	31	Red	Tray 7 if Panel 4	67		Red	Tray 8 if Panel 4		
	32	Black		68		Black			
	33	Yellow		69		Yellow			
	34	Violet		70		Violet			
	35	Rose		71		Rose			
	36	Aqua		72		Aqua			

## 8 PLUG AND PLAY SPLITTER MODULE INSTALLATION

The indoor 288 FDH 3000 cabinet can accommodate up to eighteen splitter modules. Plug and play splitter modules are equipped with either one or two input connectors. Inserting the splitter into the splitter compartment connects the splitter input connector(s) to the feeder cable connector(s). The splitter output signals are distributed with connectorized output fibers. The splitter output fibers may be stored for later use or routed to the distribution panels for connection to the distribution ports.

Additional instructions for installing plug and play splitter modules are provided in the FDH 3000 Plug and Play Splitter Installation Guide (ADCP-96-087). Use only splitters equipped with reduced bend radius fibers.

Use the following procedure to install additional splitters in the cabinet:

1. Open the cabinet door and swing frame to provide access to the splitter compartment.
2. Locate the next available splitter mounting position as shown in [Figure 41](#).
- ▶ **Note:** Install splitters in the order shown, beginning on the left side of the splitter compartment and then working toward the right.
3. Remove the dust cap assembly from the selected splitter slot.

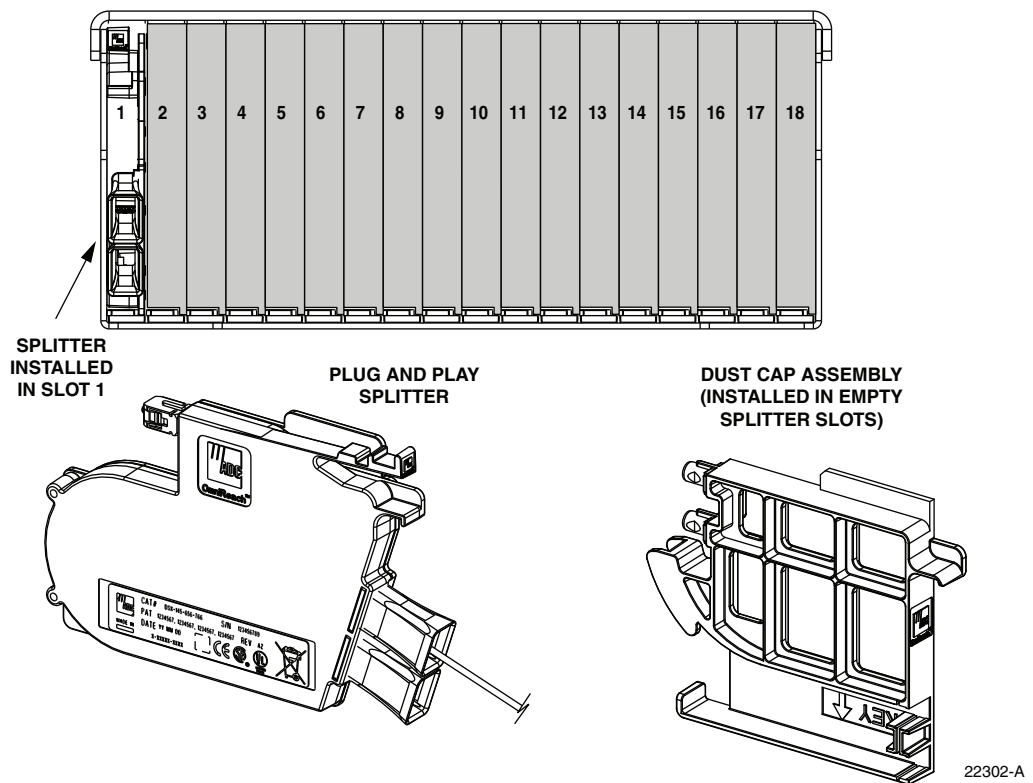
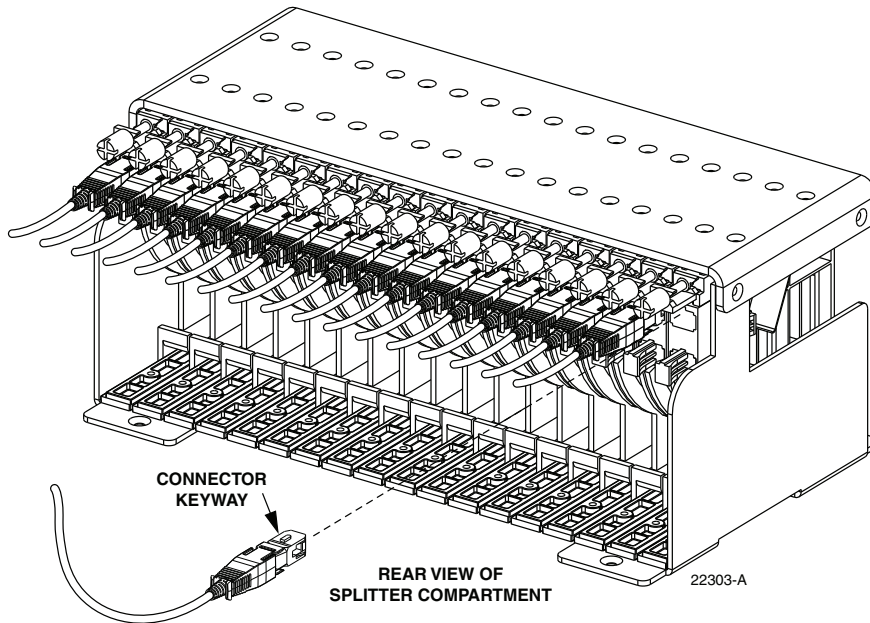

Figure 41. Splitter Module Installation

4. Remove the corresponding feeder cable connector(s) from the rear of the splitter compartment as shown in [Figure 42](#).



**Warning:** *Infrared radiation is invisible and can seriously damage the retina of the eye. Do not look into the ends of any optical fiber. Do not look directly into the optical adapters or connectors. Exposure to invisible laser radiation may result. An optical power meter should be used to verify active fibers. A protective cap or hood **MUST** be immediately placed over any radiating adapter or optical connector to avoid the potential of dangerous amounts of radiation exposure. This practice also prevents dirt particles from entering the adapter or connector.*



**Figure 42. Feeder Cable Connector**

5. Clean the feeder cable connector(s) as specified in the Optical Fiber Systems Cleaning and Mating Instructions (ADCP-90-159).
6. Reinstall the feeder cable connector(s) at the rear of the splitter compartment.
7. Remove the protective tape and dust cap from the splitter connector as shown in [Figure 43](#).
8. Grasp the splitter using thumb and forefinger ([Figure 43](#)) and gently squeeze the locking tab against the lower tab
9. Carefully slide splitter into the mounting slot. Listen for a click to ensure full engagement.



**Caution:** *Applying excessive force to the splitter during installation can cause splitter damage. If resistance is encountered when sliding the splitter into the mounting slot, remove the splitter and verify that the splitter dust cap has been removed and that no obstructions are present.*

10. Pass the splitter output fibers over the radius limiter bar as shown in [Figure 44](#).
11. Route the splitter output fibers to the connector storage panel or to the designated subscriber port. Refer to [Section 10](#) for the routing procedure.

12. Close the swing frame and cabinet door when the splitters have been installed.

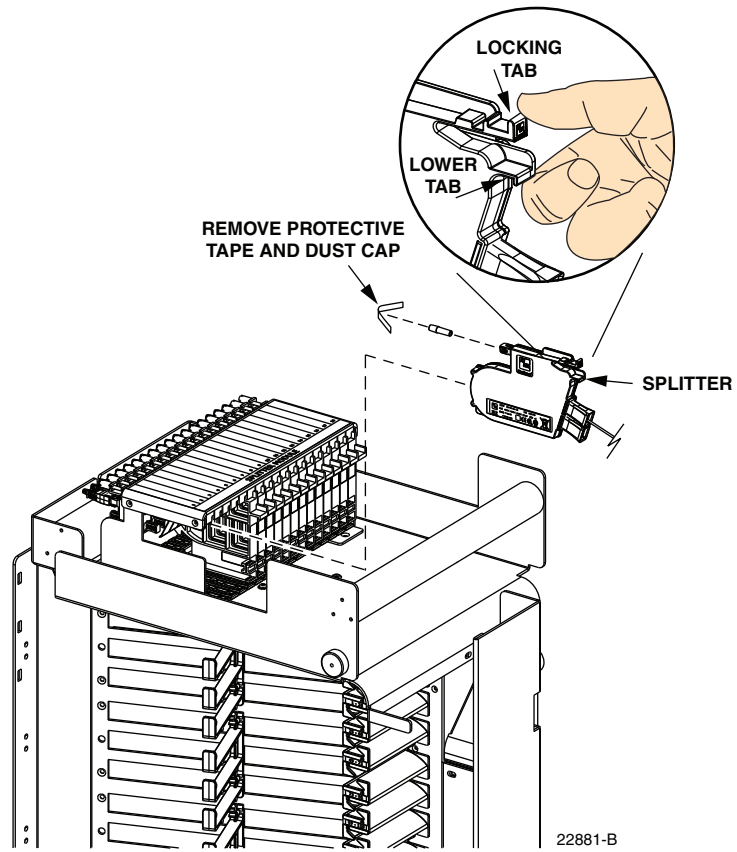

**Figure 43. Splitter Installation**

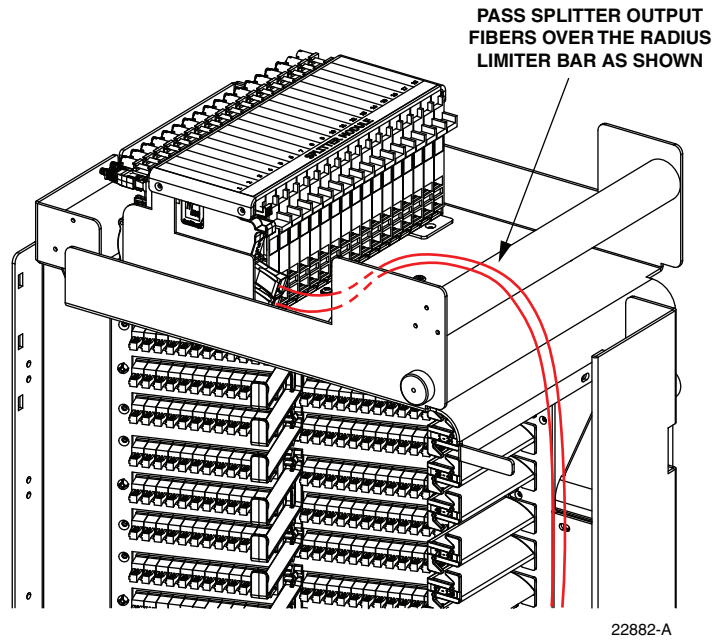

**Figure 44. Splitter Output Fiber Routing**

## 9 DISTRIBUTION PANEL INSTALLATION

The indoor 288 FDH 3000 cabinet can be ordered with up to four 72-position distribution panels pre-installed in the cabinet. If the cabinet has unused distribution panel mounting slots, then additional panels may be installed if needed. Pre-cabled distribution panels are available separately. Use the following procedure to install a distribution panel in an unused mounting slot:

1. Locate the next available distribution cable entry/exit hole on top of the cabinet as shown in [Figure 45](#).

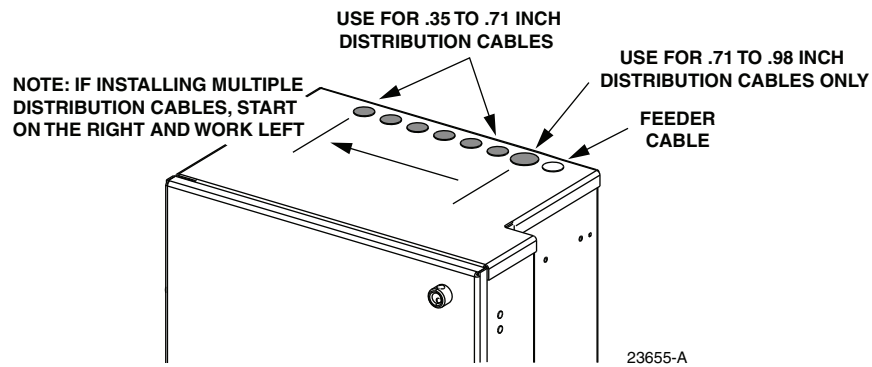

Figure 45. Cable Entry/Exit Holes

2. Remove plastic cap and retaining nut from the cable entry/exit hole as shown in [Figure 46](#).

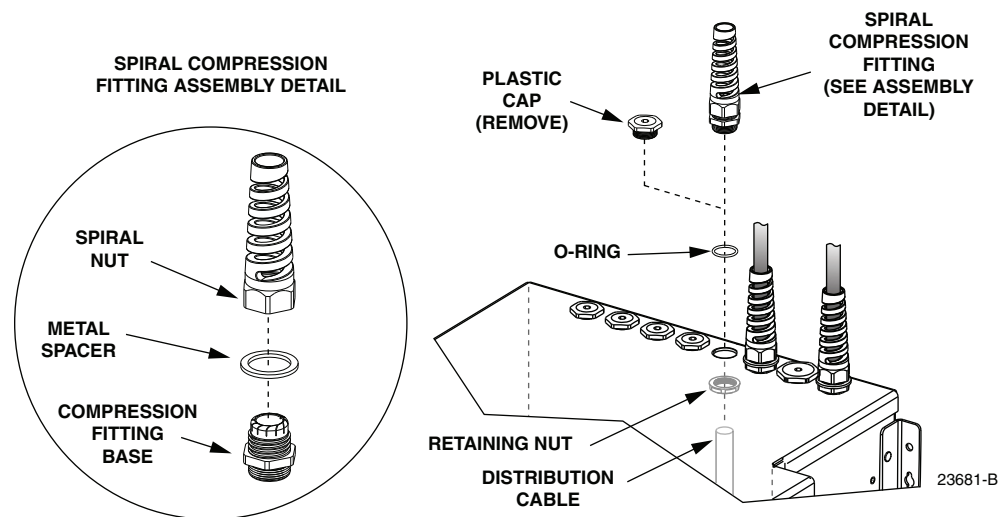

Figure 46. Plastic Cap Removal and Compression Fitting Installation

3. Install the spiral compression fitting (provided with panel) in the cable entry/exit hole.
  - ▶ **Note:** Make sure the O-ring is installed between the compression fitting base and the exterior surface of the cabinet.

4. Working from inside the cabinet, feed the distribution cable into the spiral compression fitting and then pull through the cable slack. Loosen the spiral nut if the cable does not slide freely through the fitting.
5. When all the cable slack has been pulled through the cabinet, tighten the spiral nut to secure the distribution cable at the cable entry/exit hole.
6. Assemble the cable clamp (provided with panel) and grommet (if needed) on the cable as shown in [Figure 47](#).

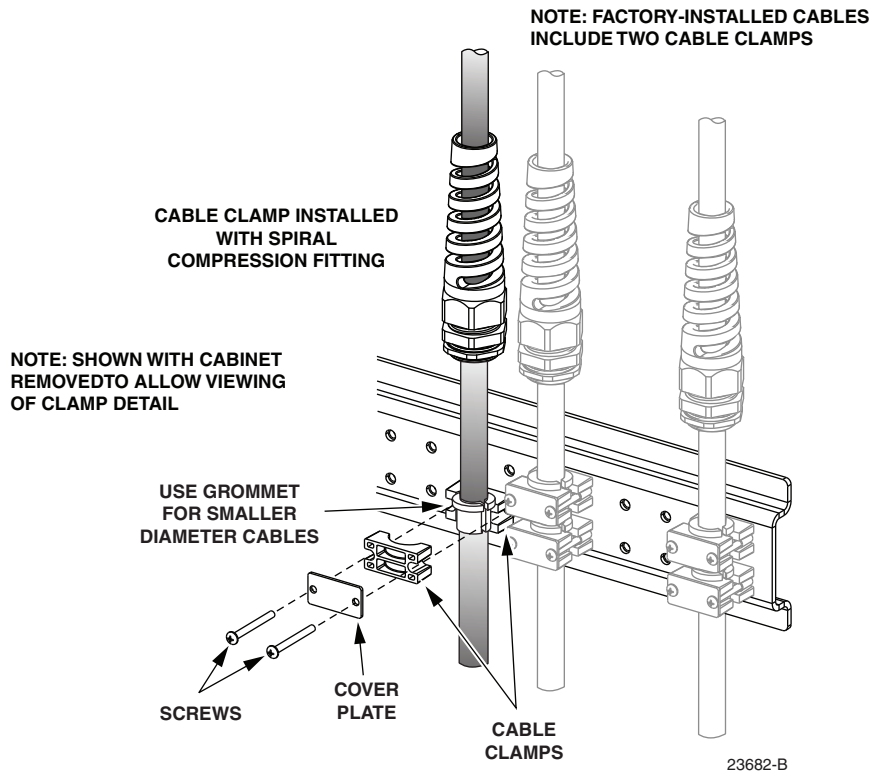
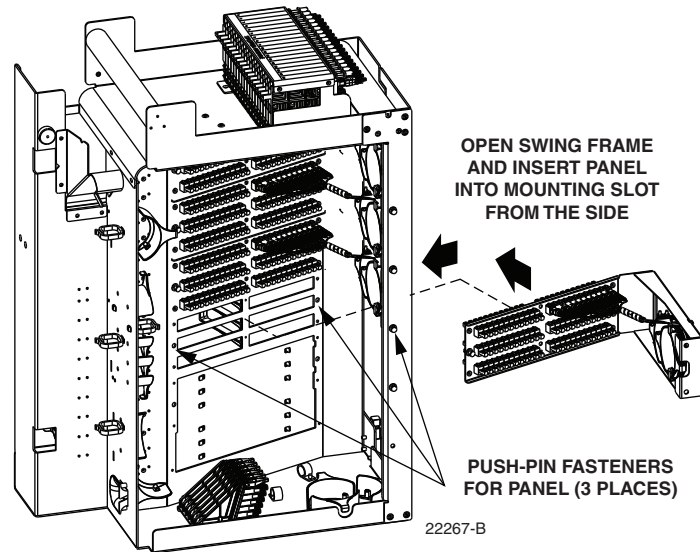

Figure 47. Cable Clamp Assembly

7. Use the cable clamp to secure the cable to the mounting bracket inside the cabinet.
8. Place the distribution panel in position for mounting on the **rear** side of the swing frame as shown in [Figure 48](#). Use the plastic push pins provided to secure the distribution panel to the rear side of the swing frame.
9. Working from the front, use the four screws (provided with panel) to secure the front of the distribution panel to the swing frame as shown in [Figure 49](#).





**Figure 48. Placing Distribution Panel In Position For Mounting**

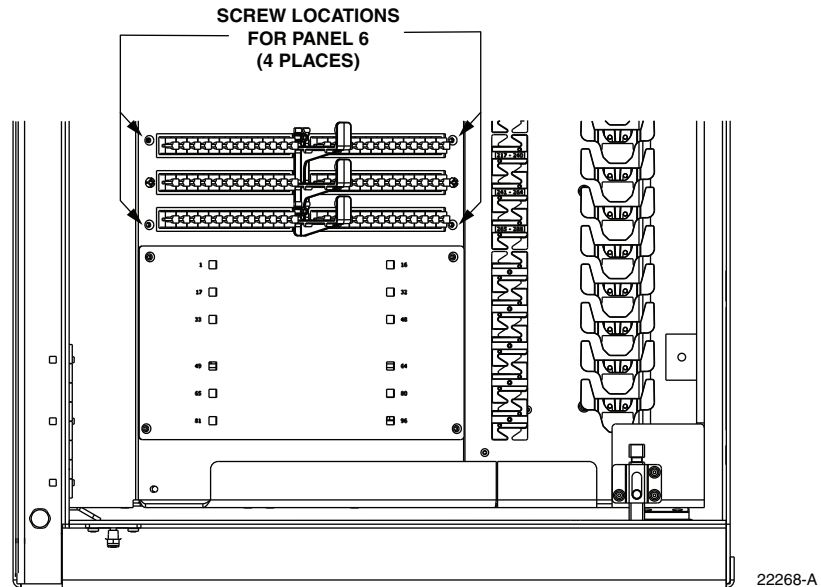

**Figure 49. Securing Distribution Panel to Swing Frame**

10. Route and secure the distribution cable subunit fibers across the side and back of the cabinet as shown in [Figure 50](#). The routing paths are numbered to correspond to the distribution panel/cable number.

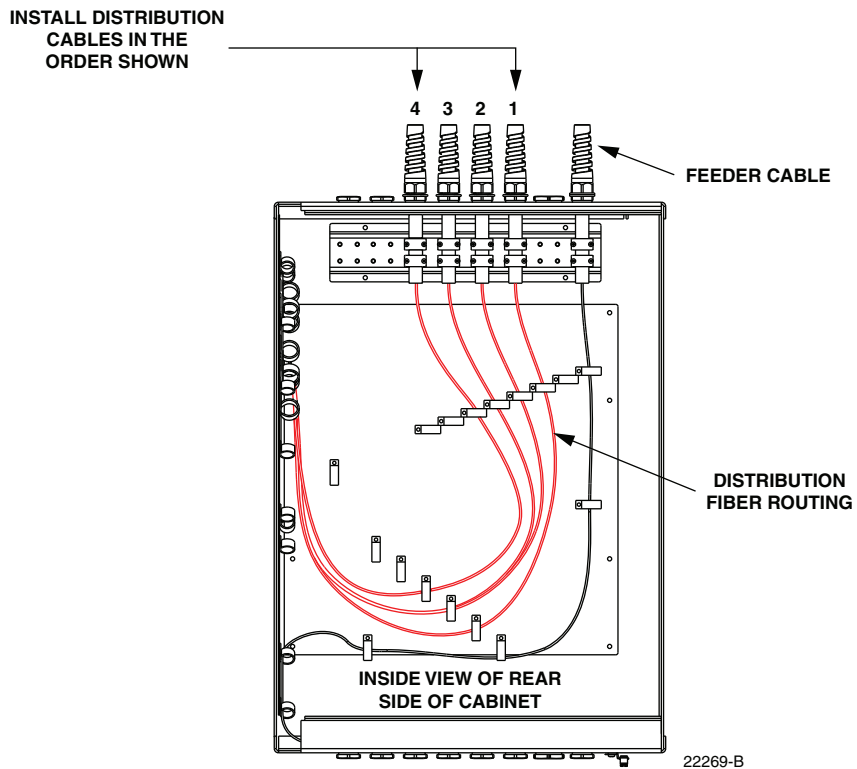
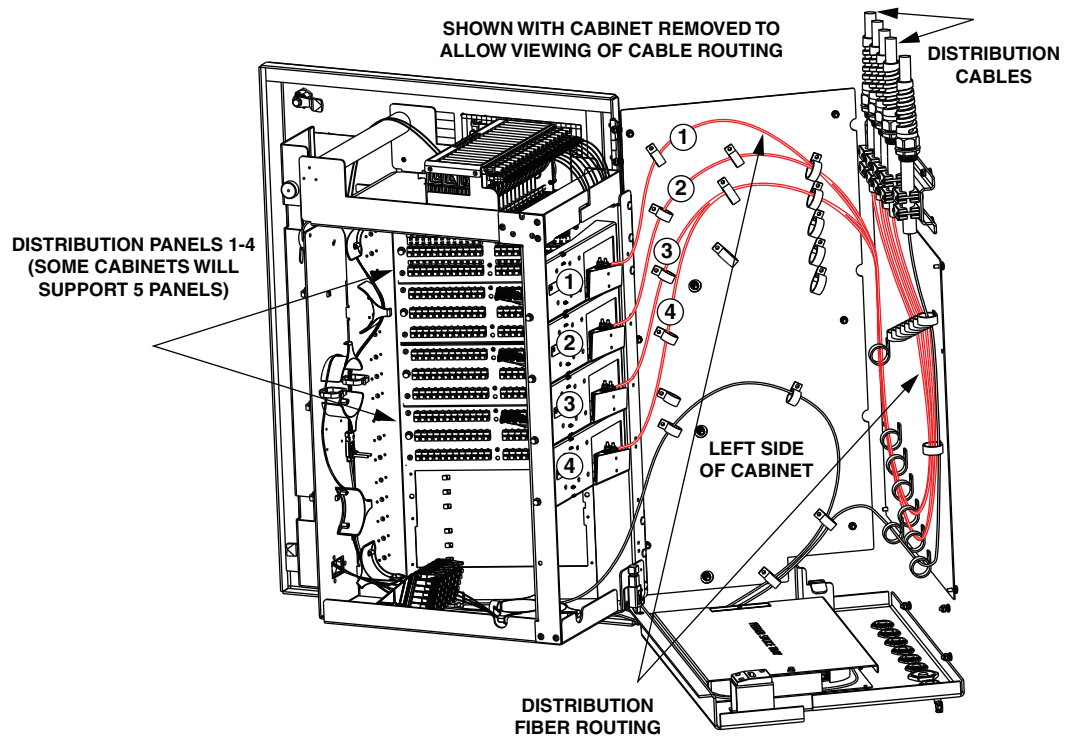

Figure 50. Distribution Cable Fiber Routing

## 10 ROUTING AND CONNECTING THE SPLITTER OUTPUT FIBERS

The splitter modules are mounted at the top of the cabinet's swing frame. When a splitter module is initially installed, the output fibers are routed to the storage panel located at the bottom of the cabinet. At the storage panel, the output fibers are temporarily "parked" until they are needed. Service to a subscriber is enabled by removing an unused output fiber from the storage panel, routing it to the appropriate distribution panel, and then connecting it to the subscriber port.

### 10.1 Storing The Splitter Output Fibers

Use the following procedure to store the splitter output fibers.

1. Following installation of a splitter module, locate an open connector pack slot in the storage panel at the bottom of the cabinet.
2. Insert the connector pack into the unused slot in the storage panel. Refer to the FDH 3000 Plug and Play Splitter Installation Guide (ADCP-96-087) provided with splitter modules for additional information on installing connector packs in the storage panel.
3. Use the radius limiters on the right side of the cabinet to store any excess fiber slack. Refer to [Figure 51](#) for the routing guidelines.

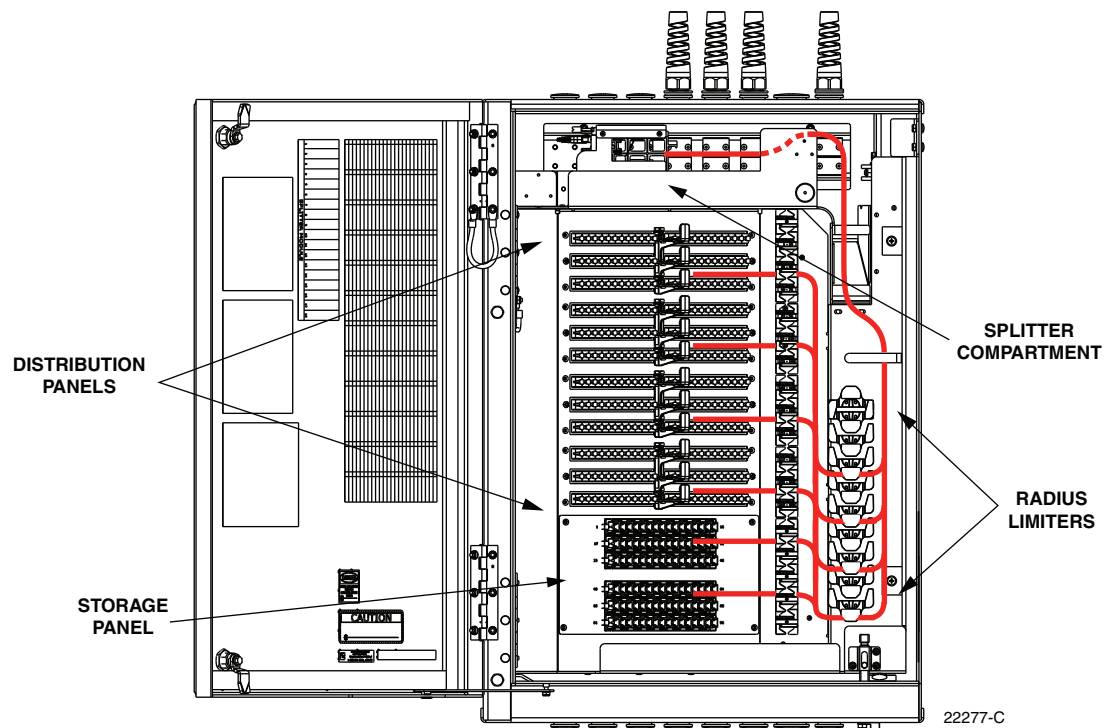

Figure 51. Routing Splitter Output Fibers

## 10.2 Enabling Service To a Subscriber

Use the following procedure to enable service to a subscriber:

1. Check the designation labels on the cabinet doors to determine the distribution panel and port number that corresponds to the address of the subscriber.
2. Locate the subscriber port on the specified distribution panel and remove both the adapter dust cap and the connector ferrule dust cap.
3. Select and remove an unused splitter output fiber from the storage panel and carefully work it free of any other fibers.



**Warning:** *Infrared radiation is invisible and can seriously damage the retina of the eye. Do not look into the ends of any optical fiber. Do not look directly into the optical adapters or connectors. Exposure to invisible laser radiation may result. An optical power meter should be used to verify active fibers. A protective cap or hood MUST be immediately placed over any radiating adapter or optical connector to avoid the potential of dangerous amounts of radiation exposure. This practice also prevents dirt particles from entering the adapter or connector.*

4. Remove the ferrule dust cap from the connector and then clean the connector as specified in the Optical Fiber Systems Cleaning and Mating Instructions (ADCP-90-159).
5. Connect the splitter output fiber connector to the subscriber port.
6. Use the radius limiters on the right side of the cabinet to store any excess fiber slack. Refer to [Figure 51](#) for the routing guidelines.



**Caution:** *Always allow sufficient fiber length to permit routing without severe bends. Non reduced bend radius fibers may be permanently damaged if bent/curved to a radius of less than 1.5 inches (3.81 cm).*

## 11 PASS-THROUGH ROUTING PROCEDURE

Pass-through routing is used when it is necessary for a feeder cable optical signal to be routed directly to a distribution port. This involves connecting a patch cord between the terminated feeder cable connector and the appropriate distribution port. Because feeder cable fibers can be terminated at either the sliding adapter pack or the splitter compartment, two pass-through routing procedures are provided.

### 11.1 Sliding Adapter Pack Pass-Through Routing Procedure

Use the following procedure to route a jumper patch cord between the feeder cable sliding adapter pack and one of the distribution panels.

1. Open the swing frame and locate the appropriate feeder cable connector on the sliding adapter pack.
2. Pull upward on the small tab on top of the adapter pack and lift the adapter pack to the position shown in [Figure 52](#)

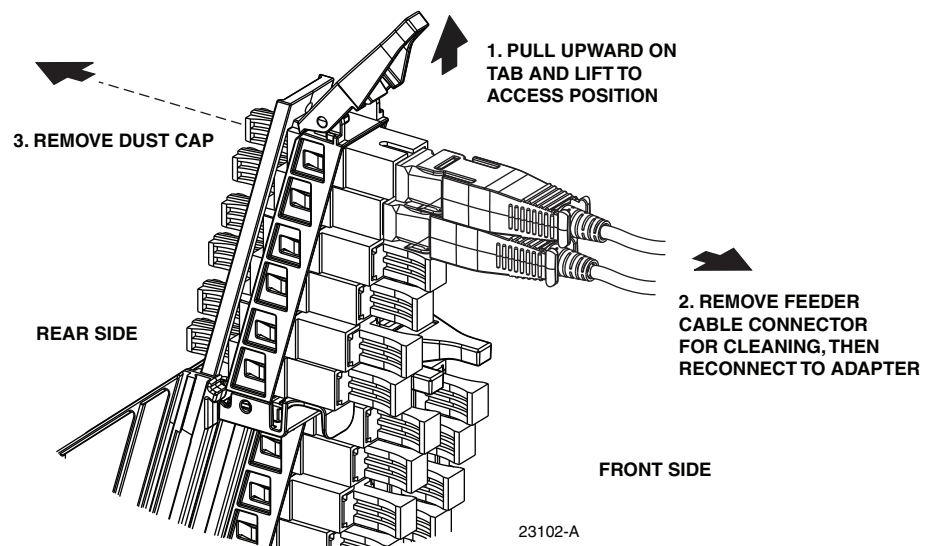

**Figure 52. Typical Adapter Pack Raised to Access Position**



**Warning:** *Infrared radiation is invisible and can seriously damage the retina of the eye. Do not look into the ends of any optical fiber. Do not look directly into the optical adapters or connectors. Exposure to invisible laser radiation may result. An optical power meter should be used to verify active fibers. A protective cap or hood MUST be immediately placed over any radiating adapter or optical connector to avoid the potential of dangerous amounts of radiation exposure. This practice also prevents dirt particles from entering the adapter or connector.*

3. Remove the feeder cable connector from the front side of the bulkhead adapter and clean the connector as specified in the Optical Fiber Connector Wet and Dry Cleaning Instructions (ADCP-90-159) or by locally approved procedures.

4. Reconnect the feeder cable connector to the bulkhead adapter.
  5. Remove the dust cap from the appropriate bulkhead adapter in the sliding adapter pack.
  6. Obtain the optical patch cord (accessory) recommended for the pass-through connection.
- ▶ **Note:** Use catalog# FPCFW-APSC-P-1.9M for APC/SC connectors.  
 Use catalog# FPCFW-SPSC-P-1.9M for UPC/SC connectors.
7. Remove the ferrule dust cap from one of the patch cord connectors and then clean the connector as specified in the Optical Fiber Connector Wet and Dry Cleaning Instructions (ADCP-90-159) or by locally approved procedures.
  8. Insert the patch cord connector into the bulkhead adapter in the sliding adapter pack.
  9. Slide the adapter pack down into the closed position.
  10. Route the pass-through patch cord to the front side of the swing frame as shown in [Figure 53](#).



**Caution:** Always allow sufficient fiber length to permit routing without severe bends. Non reduced bend radius fibers may be permanently damaged if bent or curved to a radius of less than 1.5 inches (3.81 cm).

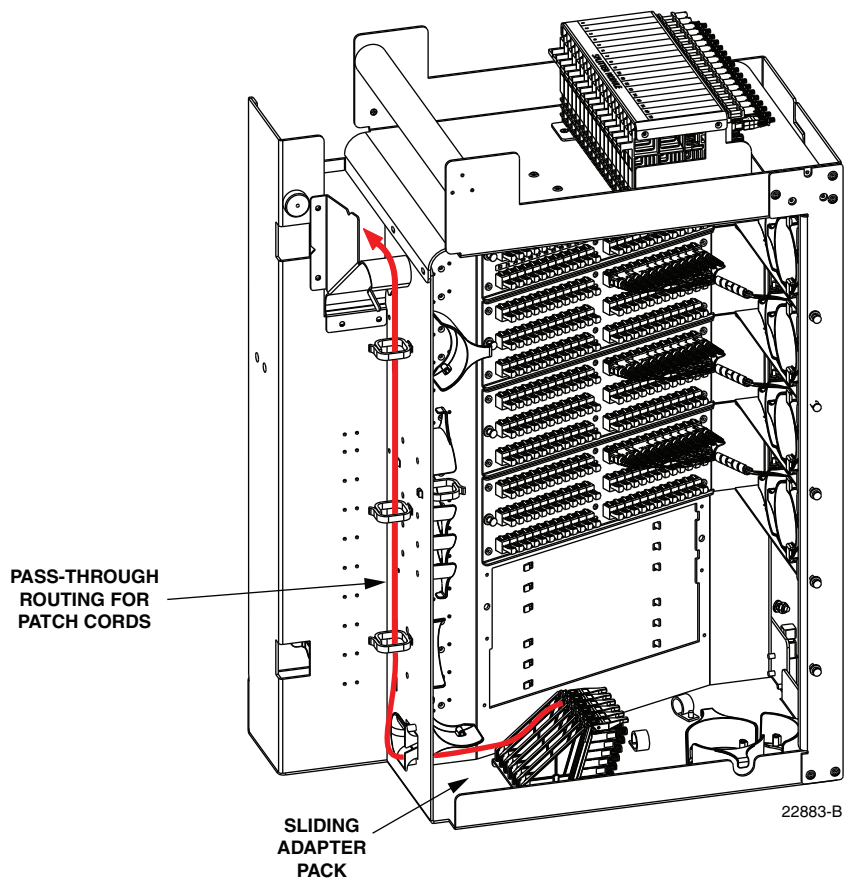

**Figure 53. Routing Pass-Through Patch Cord From Sliding Adapter Pack**

11. Locate the distribution panel and the optical port to which the pass-through patch cord is to be routed.
12. Refer to the procedures in [Section 10.2](#) to route the pass-through patch cord to the distribution panel and to connect the patch cord connector to the appropriate optical port. Maintain a 1.5-inch minimum bend radius for all non reduced bend radius fiber.
13. Close swing frame when pass-through routing procedure is complete.

## 11.2 Splitter Compartment Pass-Through Routing Procedure

Use the following procedure to route a jumper patch cord between the splitter compartment and one of the distribution cable distribution panels.

1. Open the swing frame and locate an open splitter mounting position.
2. Remove the dust cap assembly from the selected splitter slot.
3. Remove the feeder cable connector(s) from the rear of the splitter compartment (see [Figure 42](#)).



**Warning:** *Infrared radiation is invisible and can seriously damage the retina of the eye. Do not look into the ends of any optical fiber. Do not look directly into the optical adapters or connectors. Exposure to invisible laser radiation may result. An optical power meter should be used to verify active fibers. A protective cap or hood MUST be immediately placed over any radiating adapter or optical connector to avoid the potential of dangerous amounts of radiation exposure. This practice also prevents dirt particles from entering the adapter or connector.*

4. Clean the feeder cable connector(s) as specified in the Optical Fiber Systems Cleaning and Mating Instructions (ADCP-90-159).
5. Reinstall the feeder cable connector(s) at the rear of the splitter compartment.
6. Obtain the optical patch cord (accessory) recommended for the pass-through connection.
- ▶ **Note:** Use catalog# FPCFW-APSC-P-1.3M for APC/SC connectors.  
Use catalog# FPCFW-SPSC-P-1.3M for UPC/SC connectors.
7. Remove the ferrule dust cap from one of the patch cord connectors and then clean the connector as specified in the Optical Fiber Connector Wet and Dry Cleaning Instructions (ADCP-90-159) or by locally approved procedures.
8. Install the patch cord connector in the dust cap assembly as shown in [Figure 54](#).
- ▶ **Note:** Two patch cord connectors may be installed in the dust cap assembly if required.
9. Connect the patch cord connector(s) to the feeder cable connector(s) by inserting the dust cap assembly into the splitter slot as shown in [Figure 55](#).
10. Locate the distribution panel and the optical port to which the pass-through patch cord is to be routed.
11. Refer to the procedures in [Section 10.2](#) to route the pass-through patch cord to the distribution panel and to connect the patch cord connector to the appropriate optical port.
12. Close swing frame when pass-through routing procedure is complete.



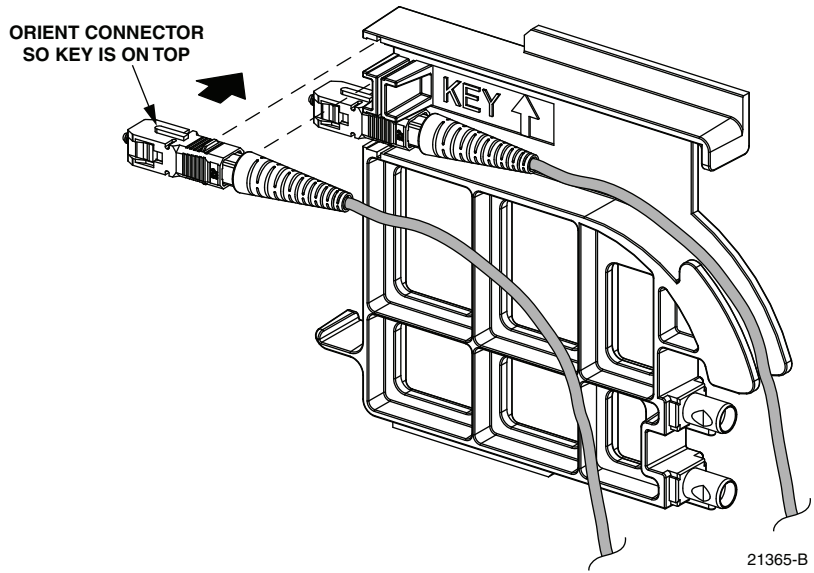

Figure 54. Installing Patch Cord Connector in Dust Cap Assembly

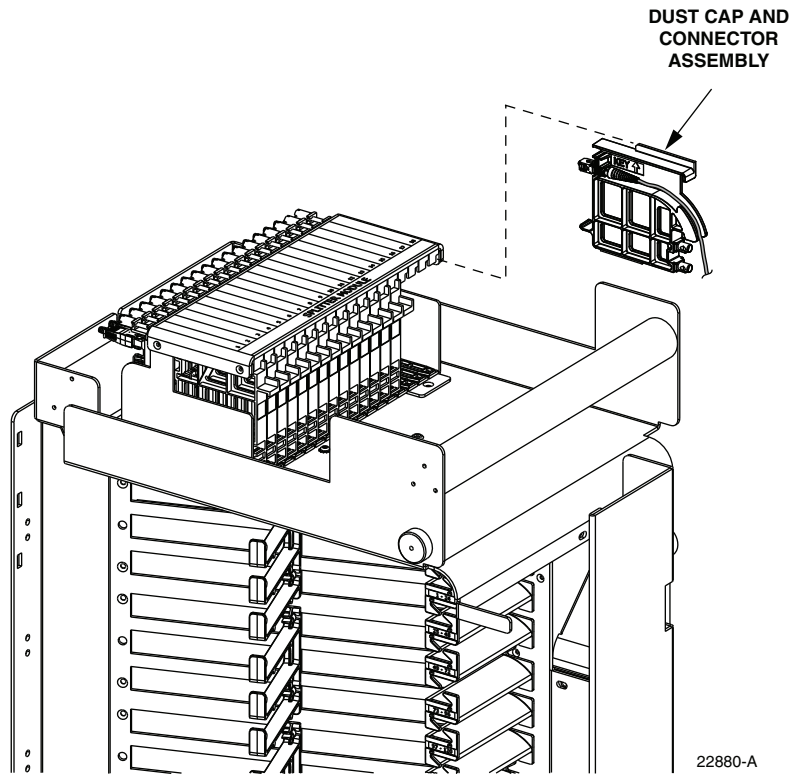

Figure 55. Inserting Dust Cap Assembly Into Splitter Compartment



## 12 FEEDER CABLE FIBER RE-ROUTING PROCEDURE

The feeder cable fibers may be terminated by the factory at either the sliding adapter pack or at the splitter compartment. Feeder cable fibers that were terminated at the sliding adapter pack may sometime require re-termination at the splitter compartment. Use the following procedure to re-route a feeder cable fiber from the sliding adapter pack to the splitter compartment.

1. Open the swing frame and locate the sliding adapter pack.
2. Locate the feeder cable fiber that requires re-termination at the splitter compartment.
3. Pull upward on the small tab on top of the adapter pack and lift the adapter pack to the position shown in [Figure 52](#).

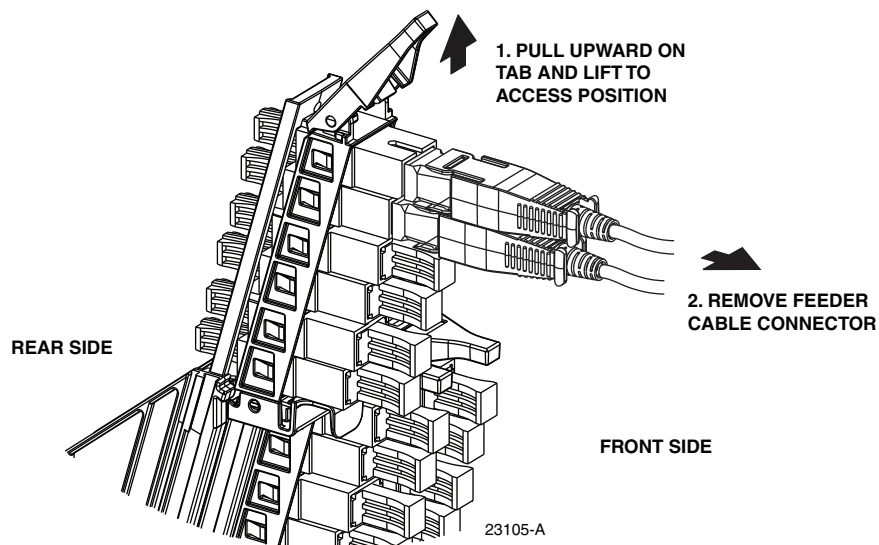

**Figure 56. Typical Adapter Pack Raised to Access Position**

4. Disconnect the feeder cable connector from the rear side of the sliding adapter pack and place a dust cap over the connector ferrule. This will protect the connector since it will be difficult to prevent the connector from getting dirty during the re-routing procedure.



**Warning:** *Infrared radiation is invisible and can seriously damage the retina of the eye. Do not look into the ends of any optical fiber. Do not look directly into the optical adapters or connectors. Exposure to invisible laser radiation may result. An optical power meter should be used to verify active fibers. A protective cap or hood MUST be immediately placed over any radiating adapter or optical connector to avoid the potential of dangerous amounts of radiation exposure. This practice also prevents dirt particles from entering the adapter or connector.*

5. Place a dust cap over the exposed bulkhead adapter and then slide the adapter pack down to the closed position.
6. Carefully unwind the feeder fiber from the radius limiters located on the bottom and on the left side of the swing frame. [Figure 57](#) shows the section of the fiber that will need to be released for re-routing. When necessary, backfeed the fiber to free the connector from the remaining fibers.

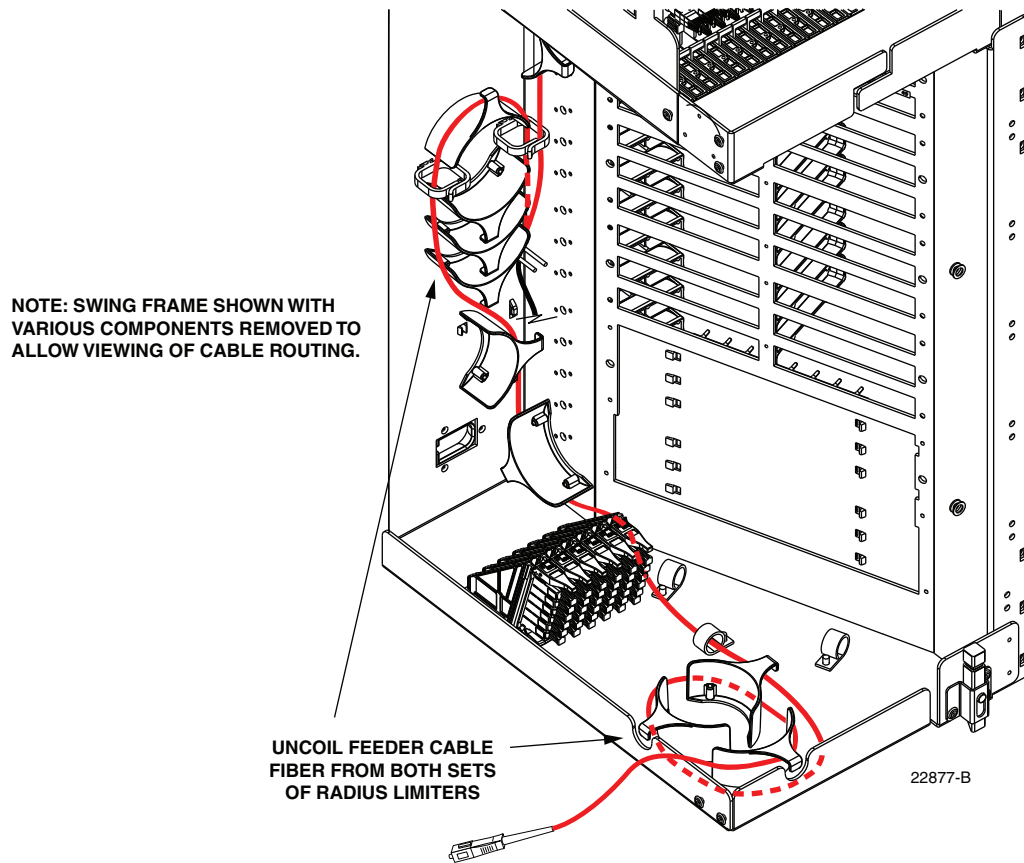

**Figure 57. Uncoiling the Feeder Cable Fiber**

7. When the feeder cable connector and fiber are free, pass the connector through the opening located behind the splitter compartment as shown in [Figure 58](#).
  8. Remove the ferrule dust cap from the feeder cable connector and then clean the connector as specified in the Optical Fiber Connector Wet and Dry Cleaning Instructions (ADCP-90-159) or by locally approved procedures.
  9. Insert the feeder fiber connector into the appropriate bulkhead adapter (remove dust cap from adapter) at the rear of the splitter compartment as shown in [Figure 59](#).
- **Note:** The splitter slot should not be left empty after the feeder fiber is connected to the bulkhead adapter at the rear side of the splitter compartment. Either a dust cap assembly or a splitter should be installed in the mounting slot.
10. Route the feeder fiber over the three supports located at the top of the swing frame.
  11. Store the excess slack on the radius limiters located on the left side of the swing frame.
  12. Close swing frame when feeder re-routing procedure is completed.

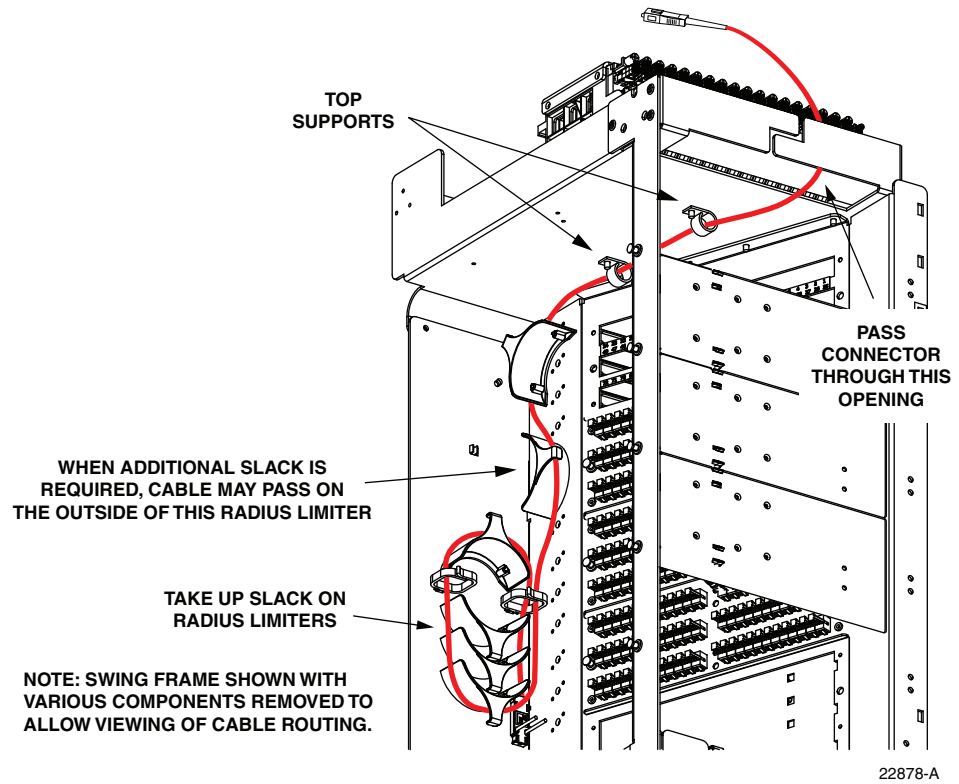

Figure 58. Re-Routing the Feeder Cable Fiber

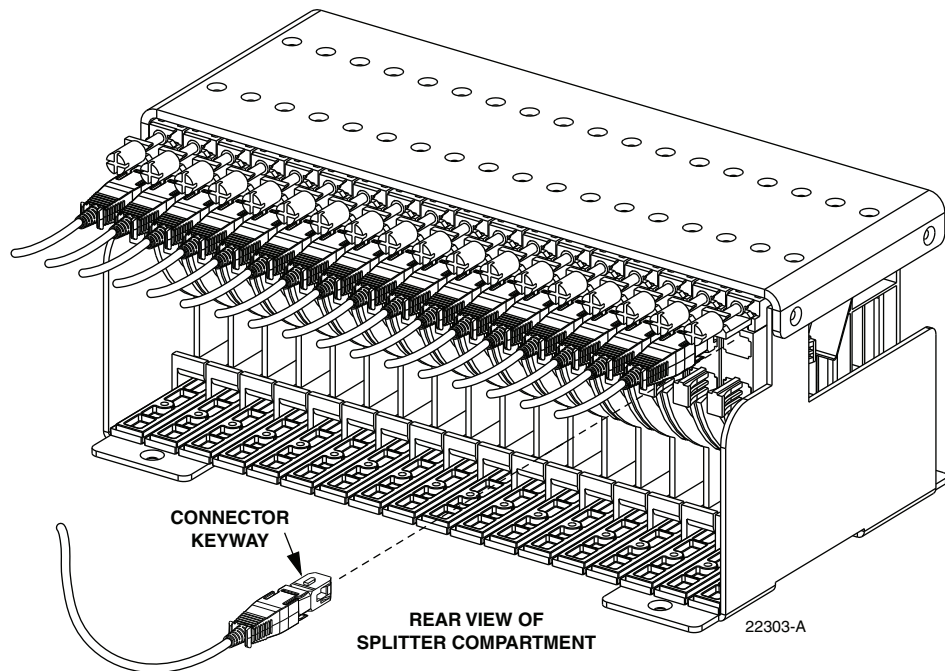

Figure 59. Feeder Cable Connector

## 13 MAINTENANCE AND REPAIR PROCEDURES

The indoor 288 FDH 3000 cabinet requires no regular maintenance to insure continuous and satisfactory operation. Maintenance is limited to repairing or replacing any cabinet components that may be damaged or broken in the course of normal operation. The following sections provide procedures for repairing or replacing common cabinet components.

### 13.1 Painting

Brush-in-cap type bottles of paint are available for touching-up nicks and scratches in the factory coat of paint. Lightly sand the area to be painted and then clean it thoroughly to remove any dirt, dust, or foreign matter. Shake the paint bottle until thoroughly mixed and then apply a light coat of paint to the damaged area using the small brush attached to the cap. Wait until the paint is dry and then apply a second coat if necessary. When finished painting, replace the paint bottle cap and tighten securely. The catalog number for the paint kit is ACE-ACC-PTALMD.

### 13.2 Distribution Panel Adapter Replacement

Replacement adapters are available for the distribution panels. Use the following procedure to remove and replace a damaged adapter:

1. Disconnect the splitter connector from the front side of the broken adapter as shown in [Figure 60](#) and install a dust cap on the connector.



**Warning:** *Infrared radiation is invisible and can seriously damage the retina of the eye. Do not look into the ends of any optical fiber. Do not look directly into the optical adapters or connectors. Exposure to invisible laser radiation may result. An optical power meter should be used to verify active fibers. A protective cap or hood MUST be immediately placed over any radiating adapter or optical connector to avoid the potential of dangerous amounts of radiation exposure. This practice also prevents dirt particles from entering the adapter or connector.*

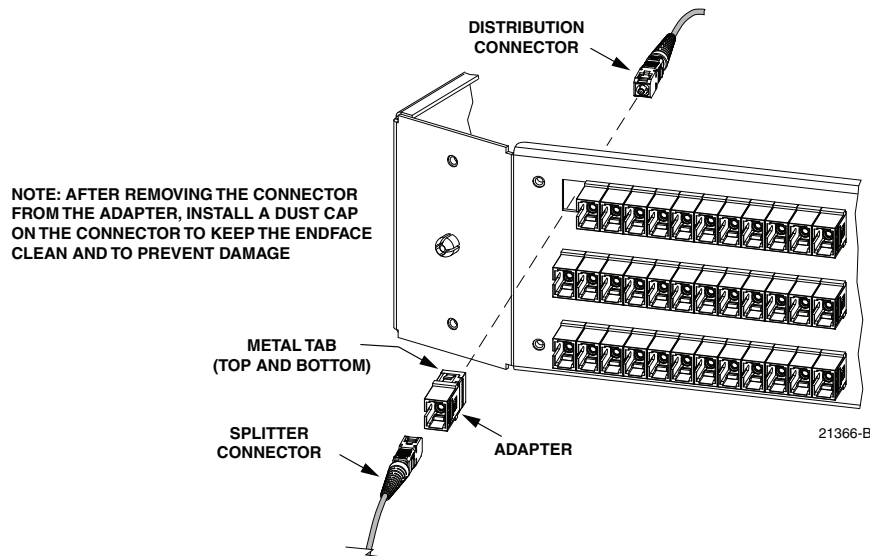

Figure 60. Adapter Removal and Replacement - Typical Distribution Panel

2. Unlatch and fully open the cabinet swing frame to provide access to the rear side of the distribution panel.
3. Disconnect the distribution connector from the rear side of the broken adapter and install a dust cap on the connector.



**Caution:** *Use extreme care when removing a connector or an adapter from the distribution panel to avoid macro bending the adjacent fibers.*

4. Working from the rear side of the distribution panel, use a large tweezers or two small screwdrivers (blade type) to depress the two metal tabs that retain the adapter in the panel. With both tabs depressed, push forward on the adapter until it pops out of the panel.
  5. Discard the damaged adapter.
  6. Install the replacement adapter by inserting it into the distribution panel from the front and then pushing it toward the back until it snaps into place.
- **Note:** Make sure the keyway in the replacement adapter is facing in the same direction as the keyways in the rest of the adapters installed in the distribution panel.
7. Clean the distribution and splitter fiber connectors as specified in the Optical Fiber Systems Cleaning and Mating Instructions (ADCP-90-159).
  8. Connect the distribution connector to the rear side of the replacement adapter.
  9. Close the cabinet swing frame.
  10. Connect the splitter connector to the front side of the replacement adapter.

### 13.3 Splitter Compartment Adapter Replacement

Replacement adapter assemblies are available for the splitter compartment. Use the following procedure to remove and replace a damaged adapter assembly:

1. Unlatch and fully open the cabinet swing frame to provide access to the both the front and rear side of the splitter compartment.
2. Remove the splitter or the dust cap assembly from the front side of the broken adapter assembly.



**Warning:** *Infrared radiation is invisible and can seriously damage the retina of the eye. Do not look into the ends of any optical fiber. Do not look directly into the optical adapters or connectors. Exposure to invisible laser radiation may result. An optical power meter should be used to verify active fibers. A protective cap or hood MUST be immediately placed over any radiating adapter or optical connector to avoid the potential of dangerous amounts of radiation exposure. This practice also prevents dirt particles from entering the adapter or connector.*

3. Remove the feeder cable connector(s) from the rear side of the broken adapter assembly as shown in [Figure 61](#) and install a dust cap on the connector(s).
4. Turn the thumb screw on the top of the broken adapter assembly clockwise until the adapter assembly detaches from the top of the splitter compartment.
5. Discard the damaged adapter assembly.

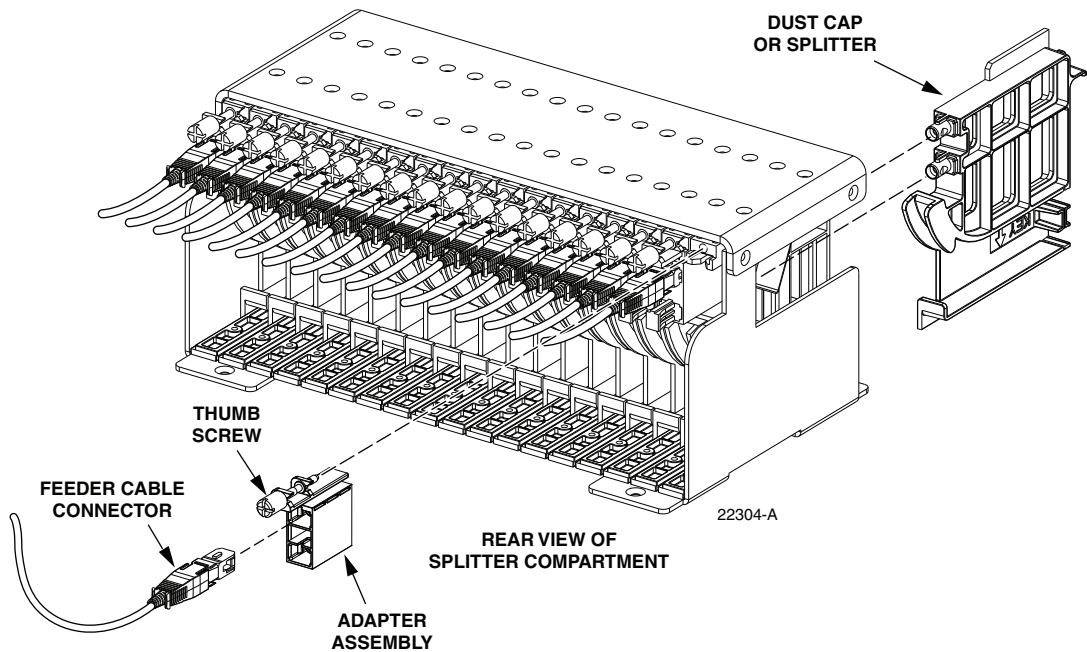

**Figure 61. Splitter Compartment Adapter Replacement**

6. Install the replacement adapter assembly in the splitter compartment and secure it by turning the thumbscrew counter-clockwise until tight.
7. Clean the feeder cable connector(s) as specified in the Optical Fiber Systems Cleaning and Mating Instructions (ADCP-90-159).
8. Connect the feeder cable connector to the rear side of the replacement adapter assembly.
9. Connect the dust cap or splitter to the front side of the replacement adapter assembly.
10. Close the cabinet swing frame.

### 13.4 Replacing a Damaged Fiber or Connector

A damaged fiber or connector can usually be replaced. The following describes the various replacement options.

- **Damaged Splitter Output Fiber:** Replace the splitter output fiber from the connector all the way back into the splitter. Splice a new pigtail (use only pigtails with reduced bend radius fiber) to the remaining section of the old fiber within the splitter chassis. This procedure requires removing and disassembling the splitter to insert a splice chip and to perform the splice. A kit is available from ADC. Refer to ADCP-96-034 for the procedure.
- **Damaged Distribution or Feeder Connector:** Replace the connector at the bulkhead adapter if just the connector alone is damaged. Use a field-installable connector replacement kit. Refer to [Section 13.4.1](#) for the replacement procedures.



### 13.4.1 Splitter Output Fiber Connector Replacement

Use the following procedure to replace the connector:

1. Disconnect the damaged connector and the good connector from the adapter and install a dust cap on the good connector.



**Warning:** *Infrared radiation is invisible and can seriously damage the retina of the eye. Do not look into the ends of any optical fiber. Do not look directly into the optical adapters or connectors. Exposure to invisible laser radiation may result. An optical power meter should be used to verify active fibers. A protective cap or hood MUST be immediately placed over any radiating adapter or optical connector to avoid the potential of dangerous amounts of radiation exposure. This practice also prevents dirt particles from entering the adapter or connector.*

2. Replace the damaged connector as specified in the procedures provided with the field-installable connector replacement kit.
3. Clean both connectors as specified in the Optical Fiber Connector Wet and Dry Cleaning Instructions (ADCP-90-159) or by locally approved procedures.
4. Reconnect the good connector and the replacement connector to the adapter.

## 13.5 Door Gasket Replacement

Damaged door gaskets may be replaced using the door gasket kit which includes a roll of gasket material. The ideal installation temperature for the adhesive used on the replacement gaskets is between 60 and 100 °F (16 and 38 °C). Installation is not recommended if the temperature is below 50 °F (10 °C). Remove any damaged sections of gasket material from the door. If necessary, use a citrus based adhesive cleaner to remove any adhesive that may stay attached to the door. Cut replacement lengths of gasket material from the roll as needed. Remove the paper backing to expose the adhesive and then carefully apply the replacement gasket to the door. Take care not to leave any gaps between the meeting sections of the gasket strips.

## 13.6 Door Replacement

A damaged cabinet door may be replaced using the door replacement kit. Use the following procedure to remove and replace the cabinet door:

1. Open the cabinet door and lock it in the open position as shown in [Figure 62](#).
2. Use a Phillips screwdriver to remove the screw and slide fastener that secure the door linkage to the door as shown in [Figure 63](#). Save the screws and slide fastener for reuse.
3. Use a 3/8-inch nut driver to remove the locking nuts that secure each hinge to the door. Save nuts for reuse.

► **Note:** Support the door as the last nuts are removed to prevent the door from falling.

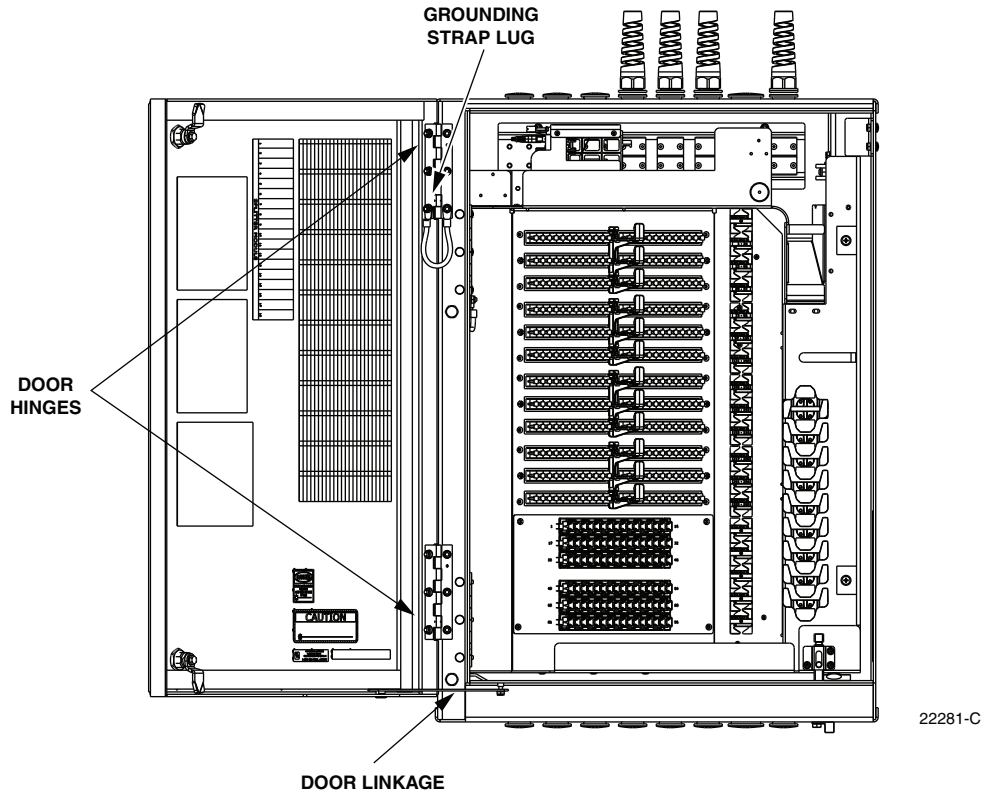

Figure 62. Door Replacement

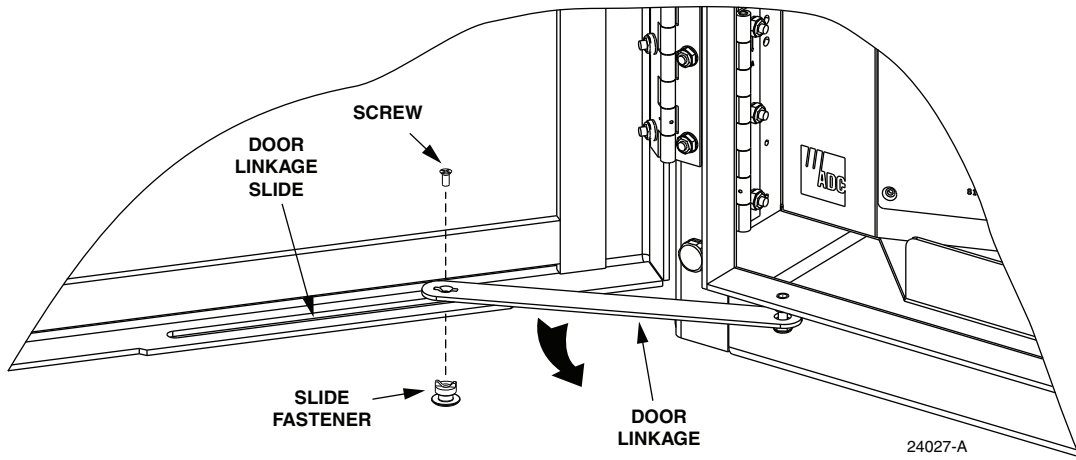

Figure 63. Door Bracket Slide Removal



4. Carefully lift the door away from the cabinet.
5. Transfer all designation information that may be recorded on the damaged door to the labels on the replacement door.
6. Place the replacement door in position for installation on the hinges.
7. Reinstall the locking nuts (saved in step 3) that secure each hinge to the door.
- ▶ **Note:** Be sure to re-secure the grounding strap lug (see [Figure 62](#)) to the door when securing the hinges to the door.
8. Reinstall the screw and slide fastener (saved in step 2) that secure the door linkage to the top of the door.
9. Close door and check for proper operation.

## 14 CUSTOMER INFORMATION AND ASSISTANCE

- To find out more about CommScope® products, visit us on the web at [www.commscope.com](http://www.commscope.com)
- For technical assistance, customer service, or to report any missing/damaged parts, visit us at <http://www.commscope.com/SupportCenter>

COMMSCOPE®